

BF16
Assembly Instructions for
SmartPlug Boatside Connector

For questions, comments or concerns please call 206-285-2990 or email at info@smartplugsystems.com

- #2 Phillips Screwdriver
- Wire Cutters
- Utility Knife
- Liquid Soap
- Rag or Paper Towels

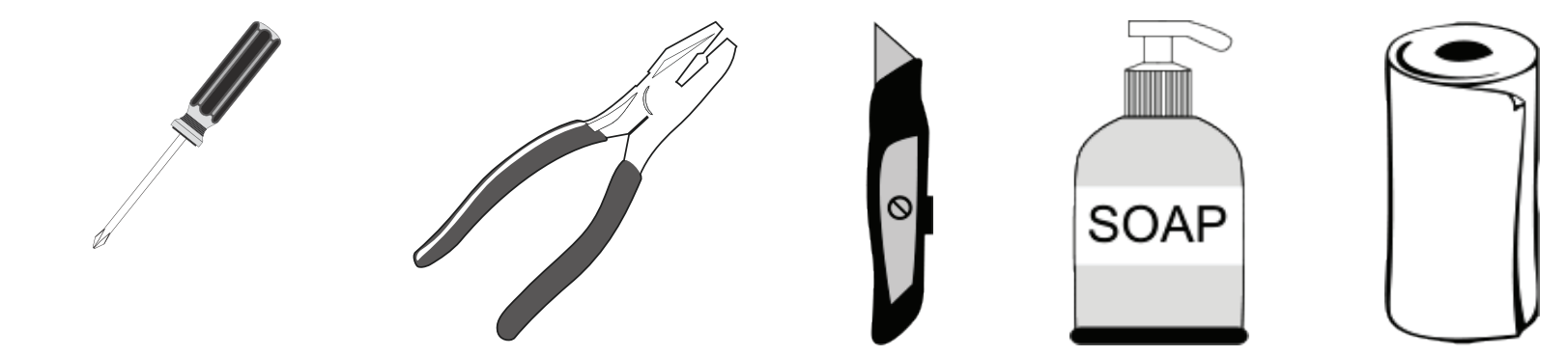

Tools Needed

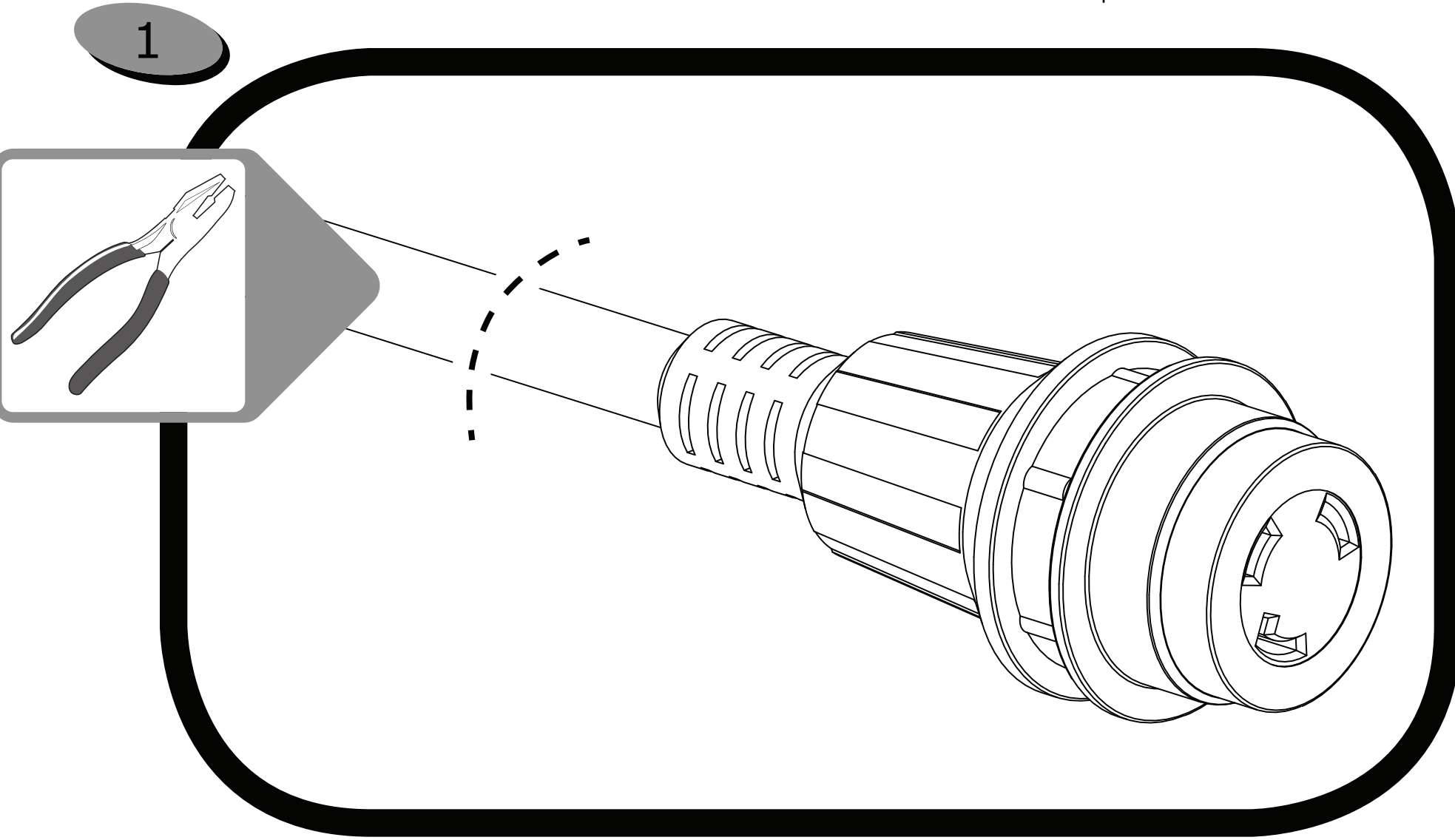

Cut female cord-end from your existing 16A/230V Cord-set. Inspect copper wires for corrosion, and cut back more cord if necessary to reach bright copper.

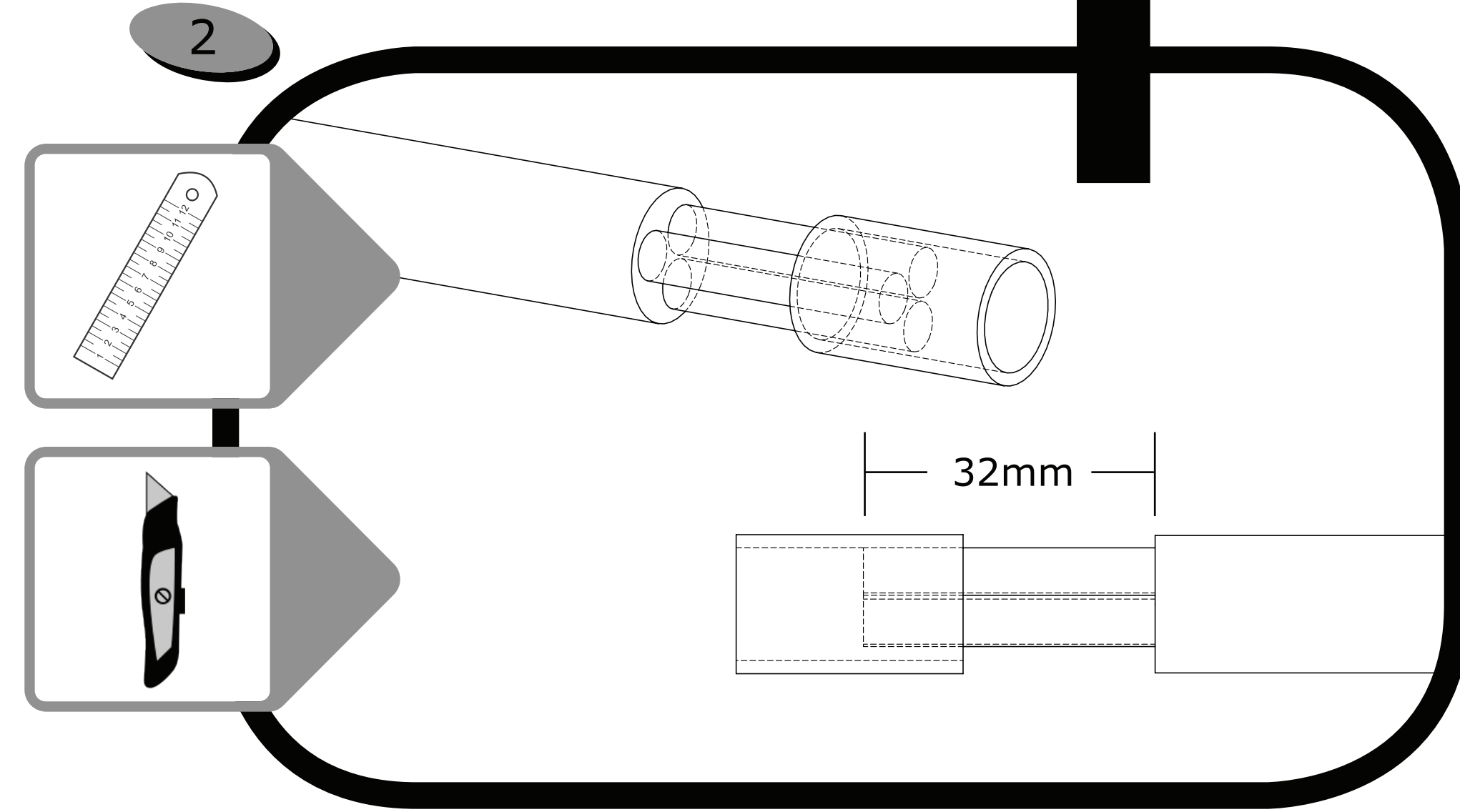

Measure 32mm back from freshly cut cord end and use marker to indicate cut. Lightly score the outer jacket with a utility knife and be sure not to cut any inner wires. Remove only the 32mm segment of outer jacket exposing the inner wires and the fibrous cord filler. Cut away all strands of filler.

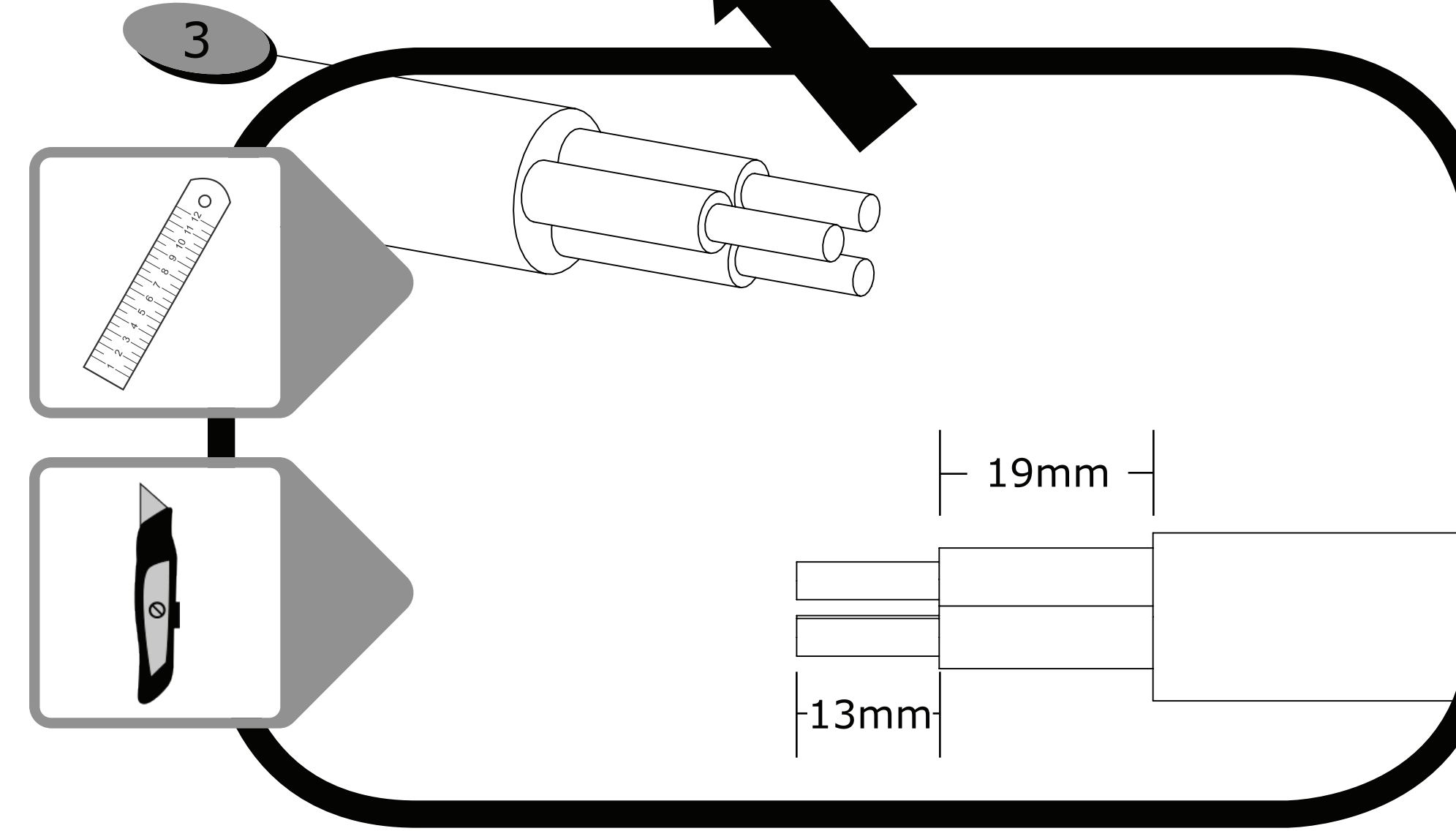

Measure and cut 13mm of inner wire jacket from each of the individual color coded conductors.
NOTE: Inspect all freshly exposed copper for corrosion. If corrosion is present, re-cut entire cord several inches back or until you find bright copper. Then repeat steps 1-3. Set aside and continue to step 4.

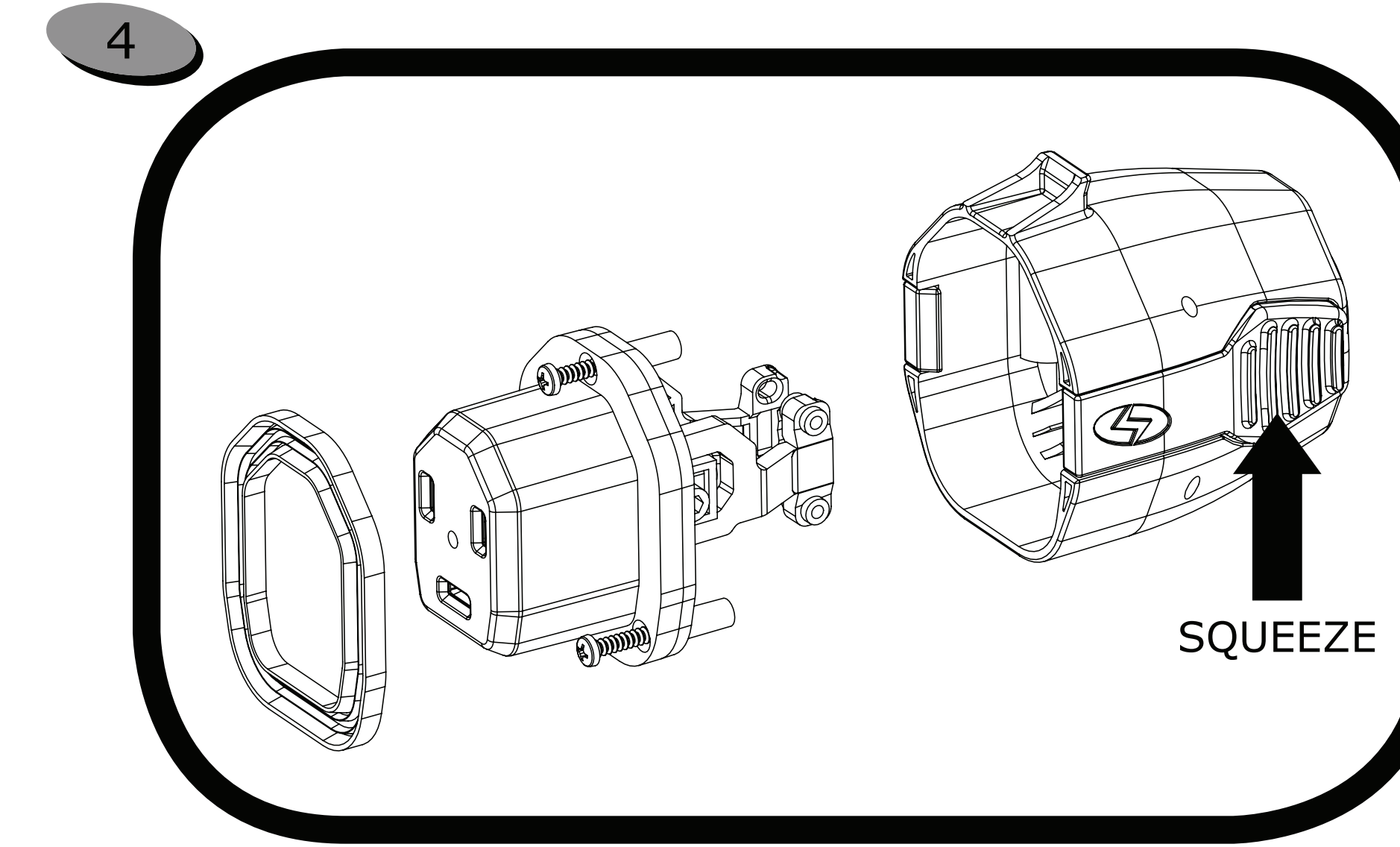

Separate the gasket, connector face and the 3 screws from each other by removing connector face from connector body. Squeeze levers and pull them apart. Set connector face assembly aside.

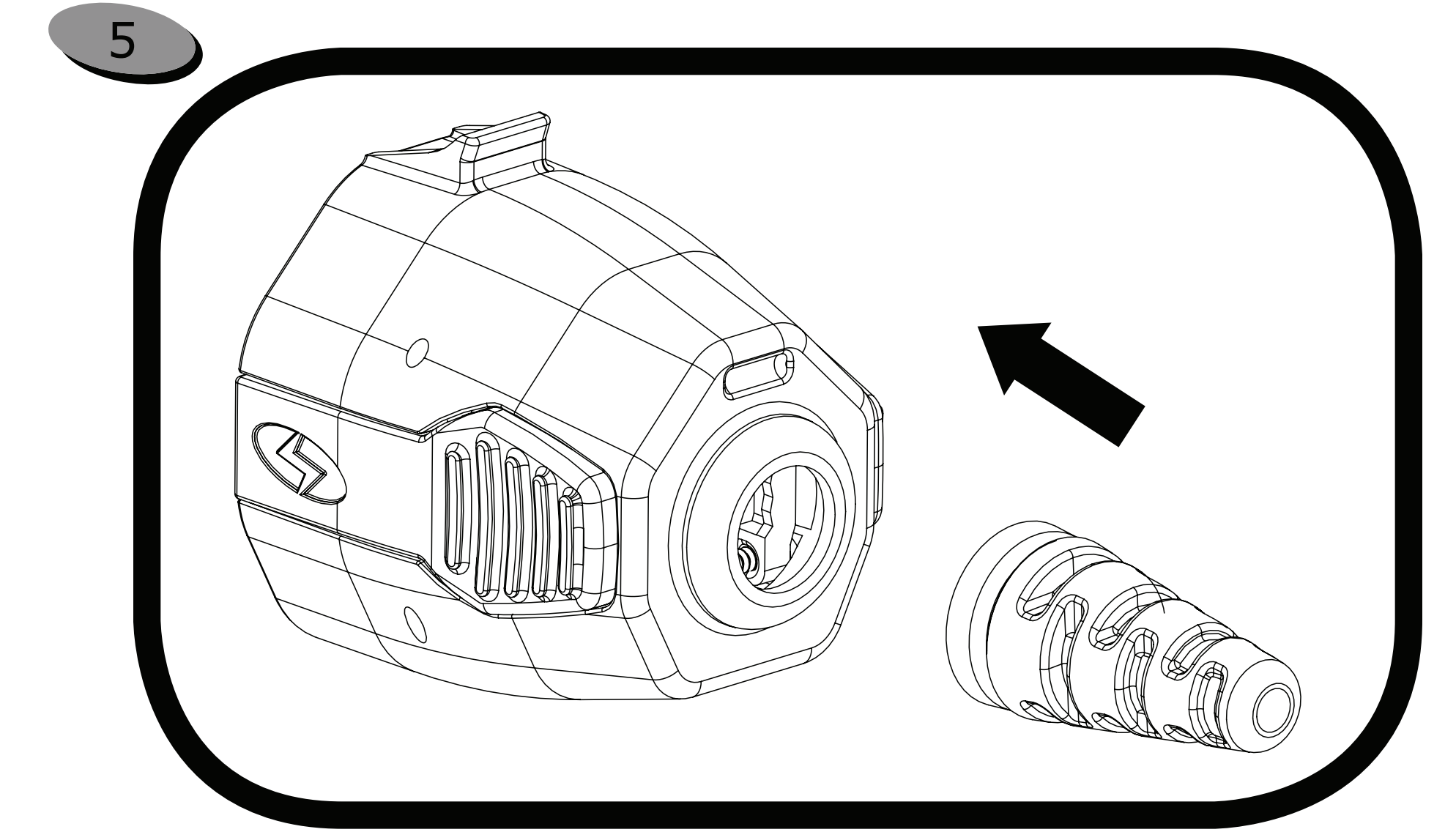

Place small amount of soap onto cord seal as shown. Insert by placing cord seal into main cavity of connector body. Use one hand to hold connector body steady, use the other hand to carefully wiggle seal through the rear of plug body. Visually inspect seal so that it is free from folds or kinks and is fully seated.

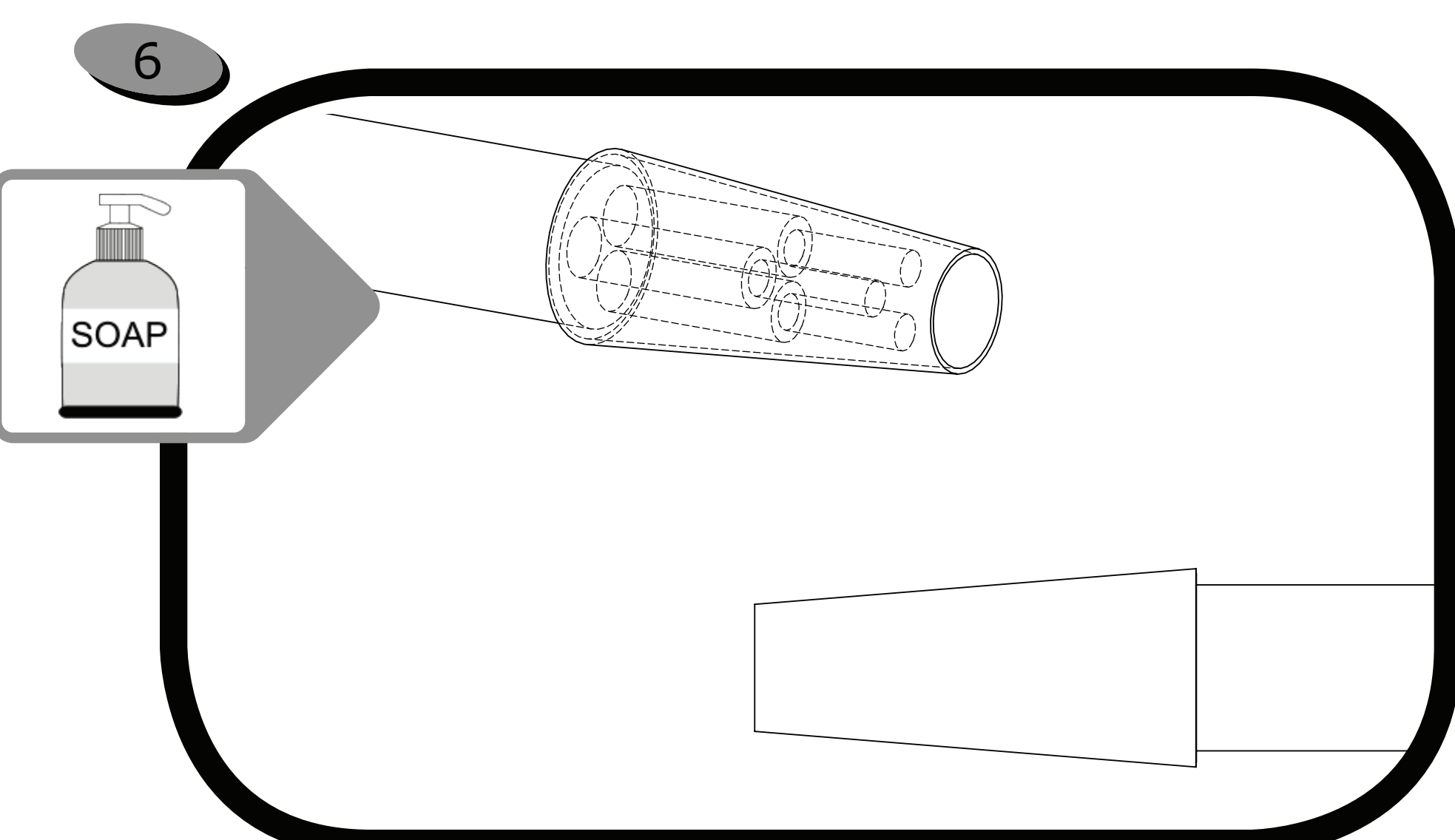

Use the cone shaped cord-install tool and cover the end of the prepared cord as shown apply liquid soap liberally on cord install tool and 45cm of cord.

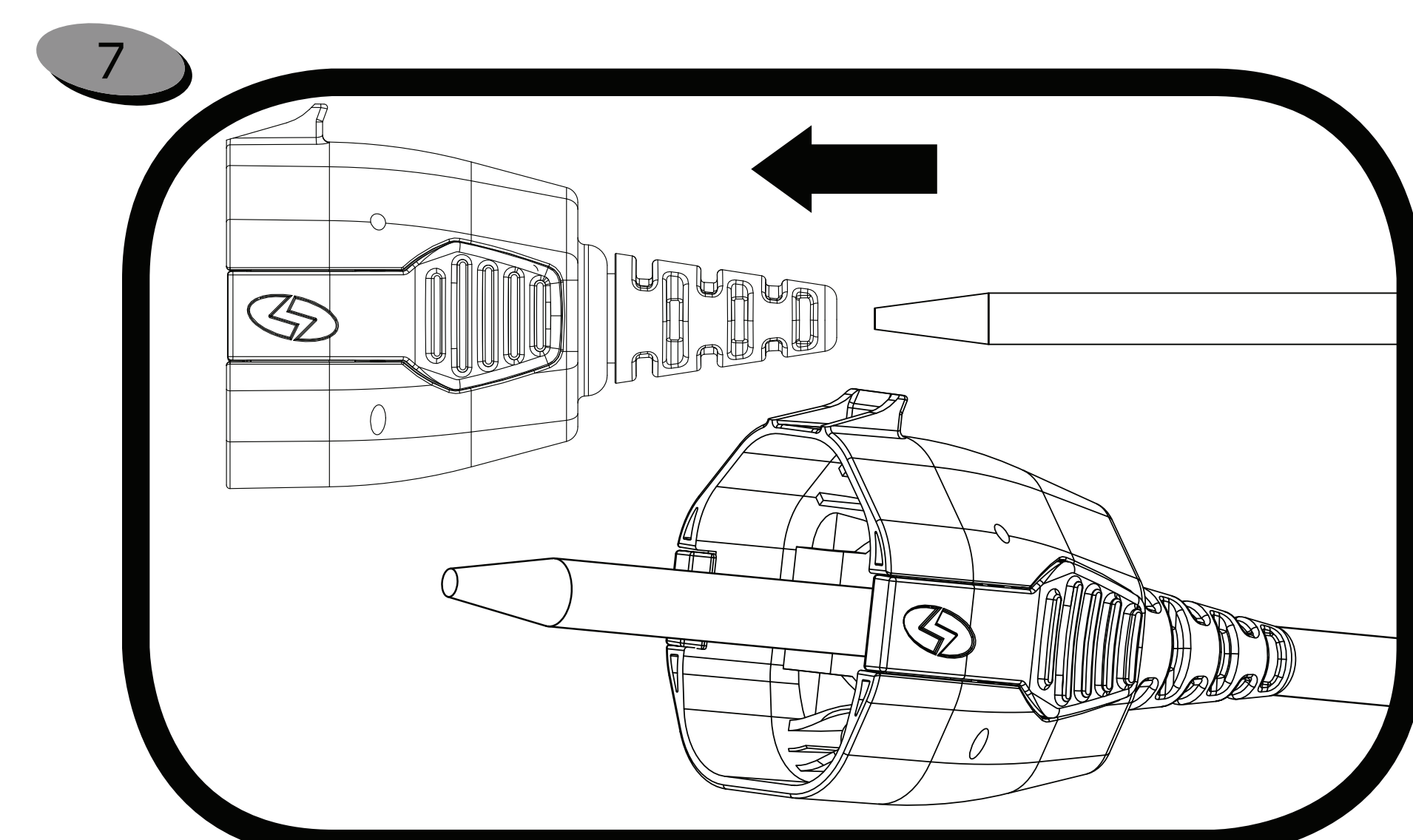

Push lubricated cord with cord-install tool through cord seal and connector body from REAR as shown. Continue pushing cord until 15-20cm of cord has moved past the front of the connector body. Remove install tool.

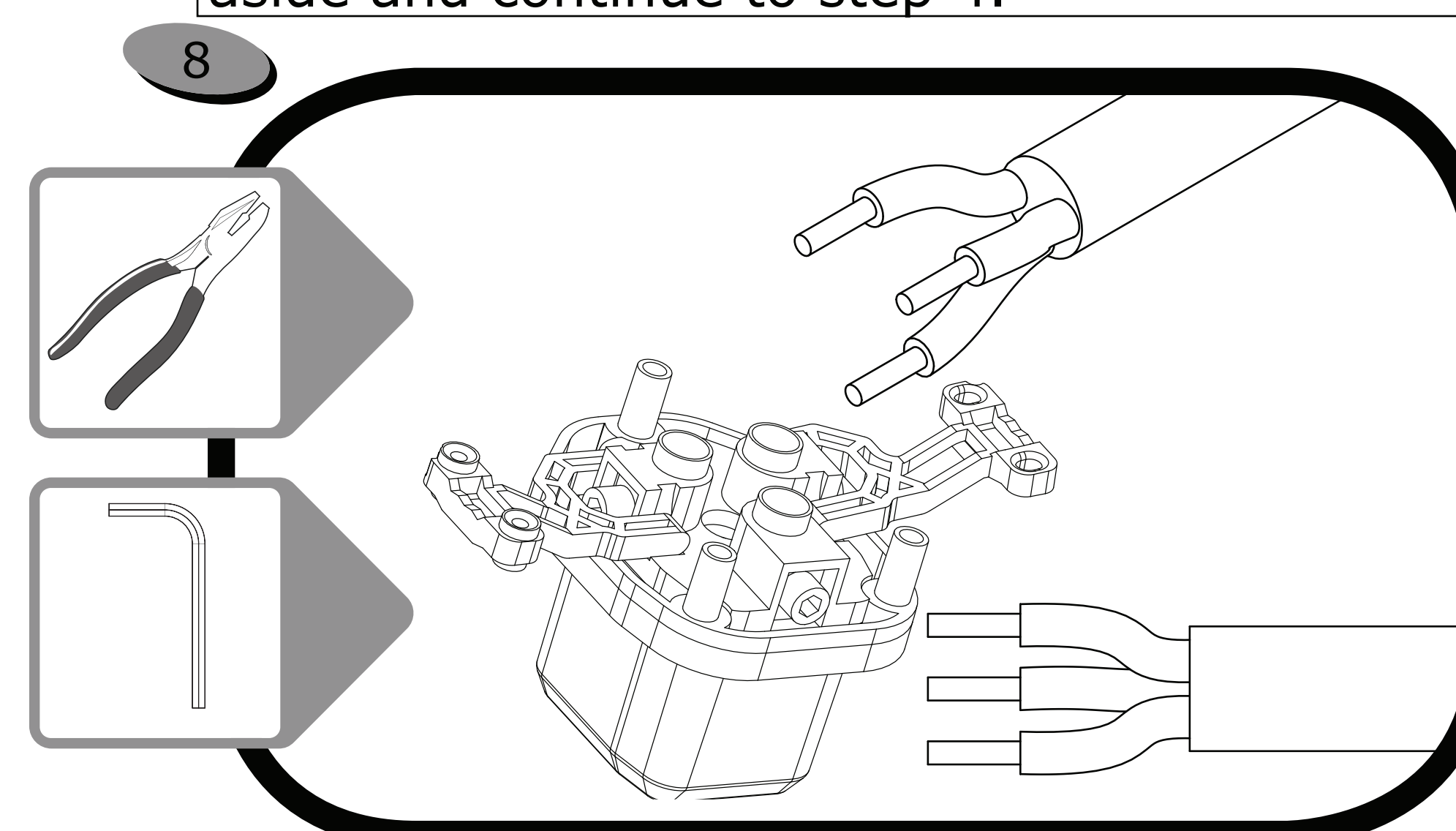

For ease of alignment, use pliers and slightly bend the ends of the conductor wires as shown. Next, use the provided hex key and loosen the set screws in the front connector assembly to allow plenty of clearance for the insertions of the copper strands into the inlet holes.

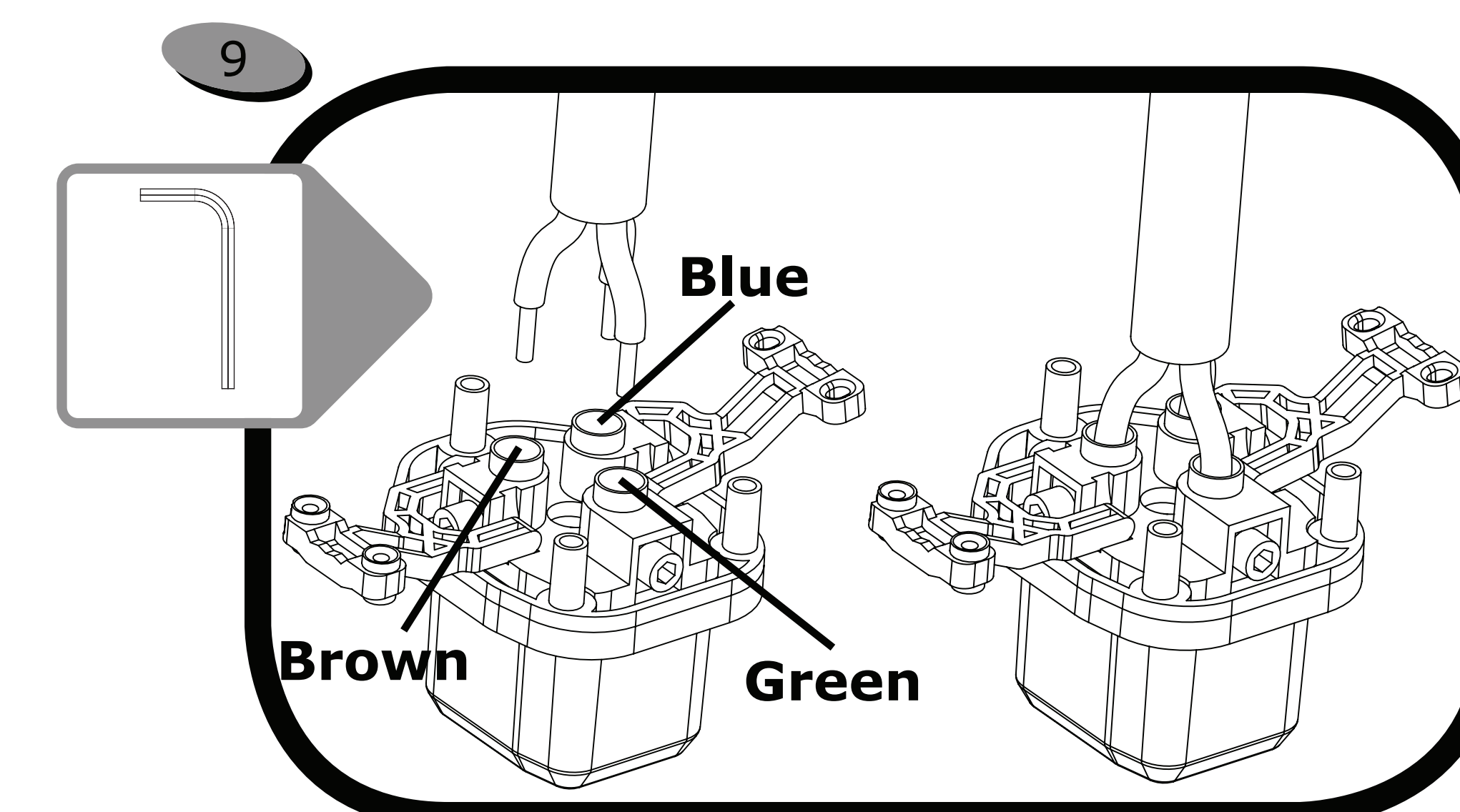

Simultaneously align and insert the individual wires into their corresponding color-coded inlets as shown. Push all wires in as far as they will go. Make sure all copper wiring is fully captured within the rear of the metal capture. Visually inspect through the clear plastic inlets that there are no stray copper strands. Use the hex key and tighten all screws to 1.75Kgf/cm².

Green Inlet-Green Wire (Ground)
Brown Inlet-Brown Wire (Hot) (L1)
Blue Inlet-Blue Wire (Neutral)

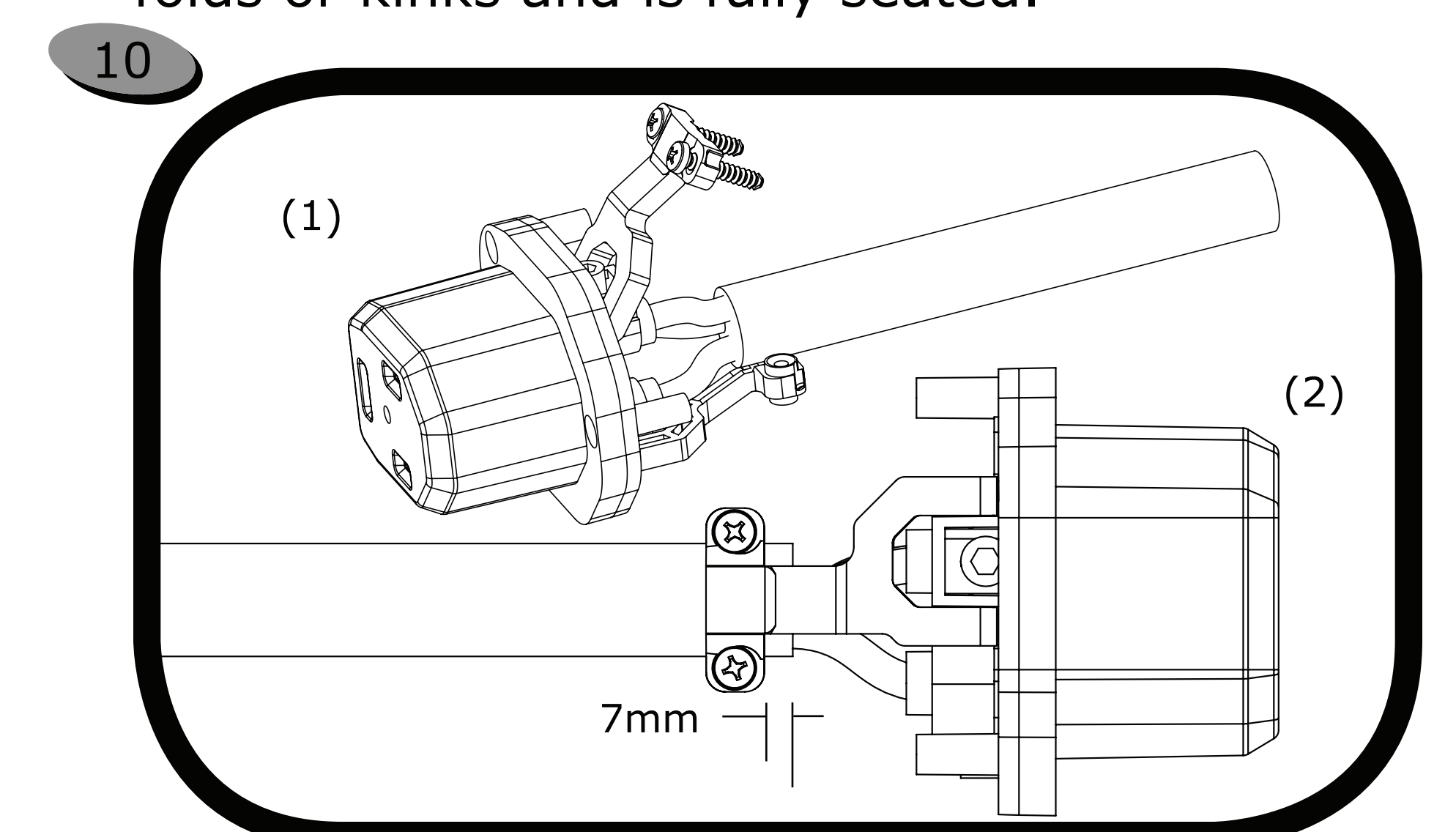

Close cable clamp arms around cable jacket as shown (1) and make sure a minimum of 7mm of cable jacket extends beyond the jaws of the cable clamps (2). Insert (2) #6x32mm screws (included) and pinch cable clamps around cable to hold them steady.

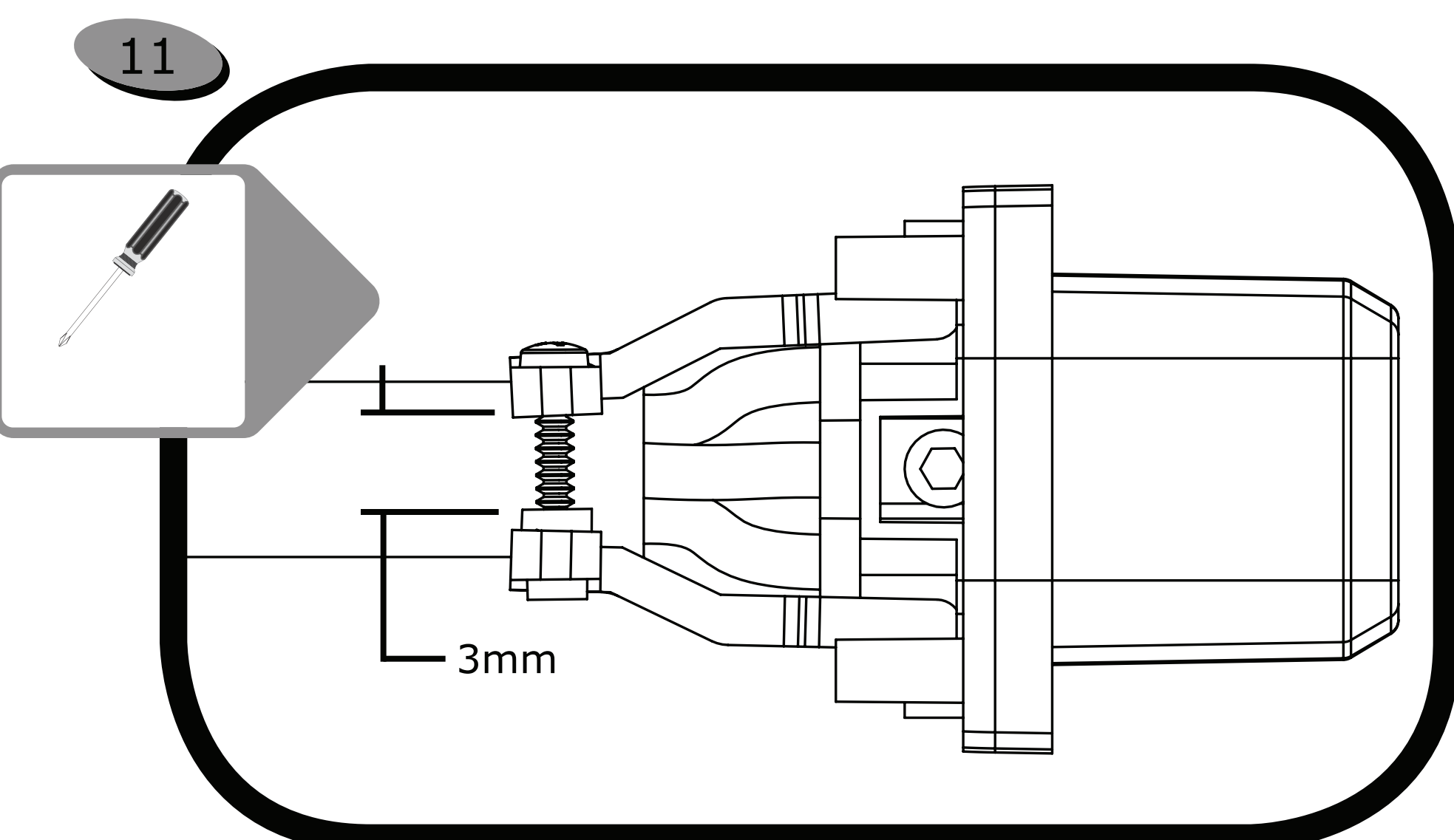

Use Phillips #2 screwdriver and tighten screws evenly about 1 turn each while alternating from one screw to the other until cable is sufficiently captured. Do not exceed 14lbs/in torque specification. Do not over tighten screws into cable clamp swing arm. A small gap as shown is acceptable, and should be even on both sides. About a 3mm gap is correct. No gap may occur for smaller diameter cords.

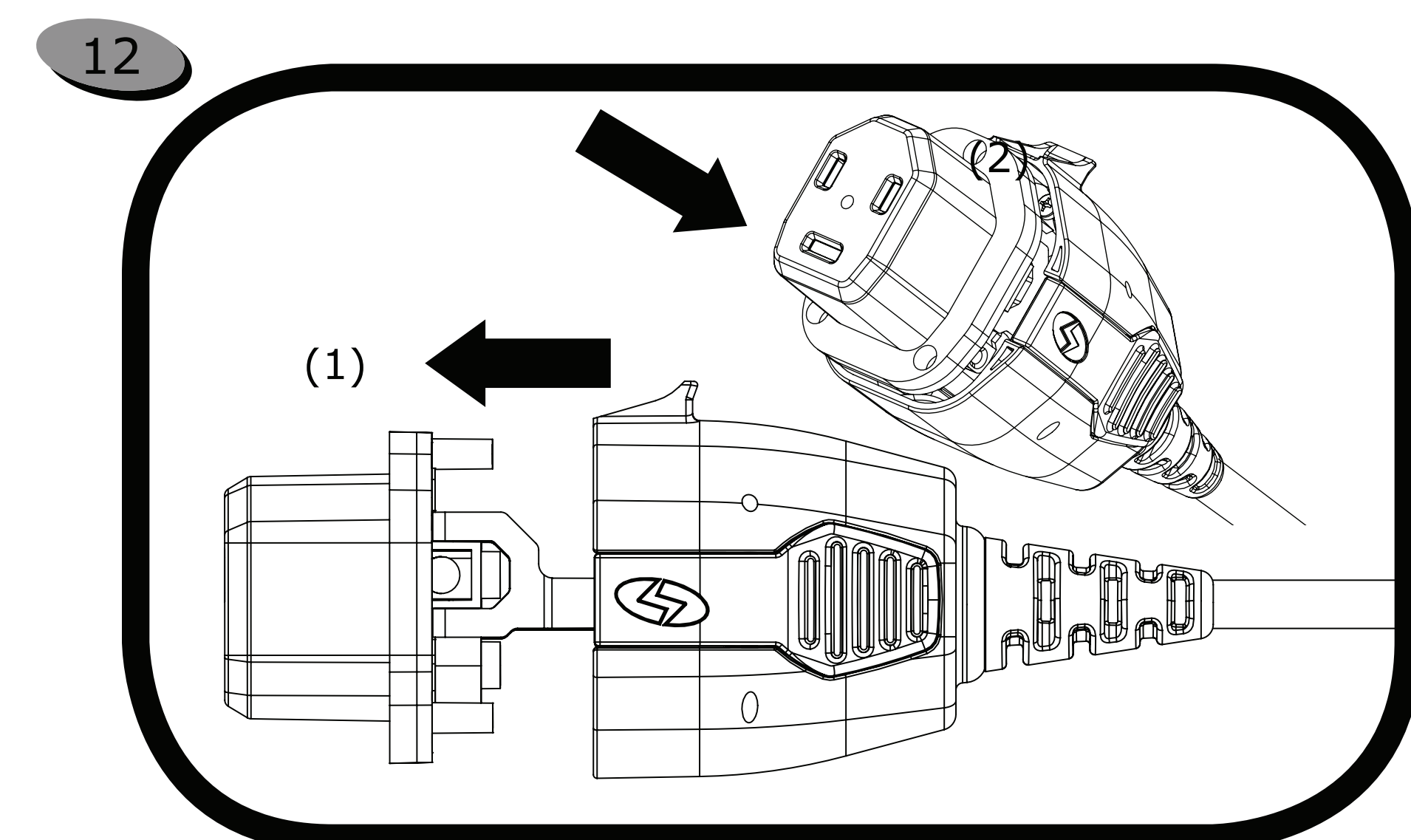

Hold cord seal and connector body in one hand as shown (1) and carefully pull cord with other hand backwards until it begins to enter connector body only.
CAUTION!! Do not pull components completely together.
Carefully push components together as shown (2) until assemblies are fully seated. Wipe clean any excess soap.

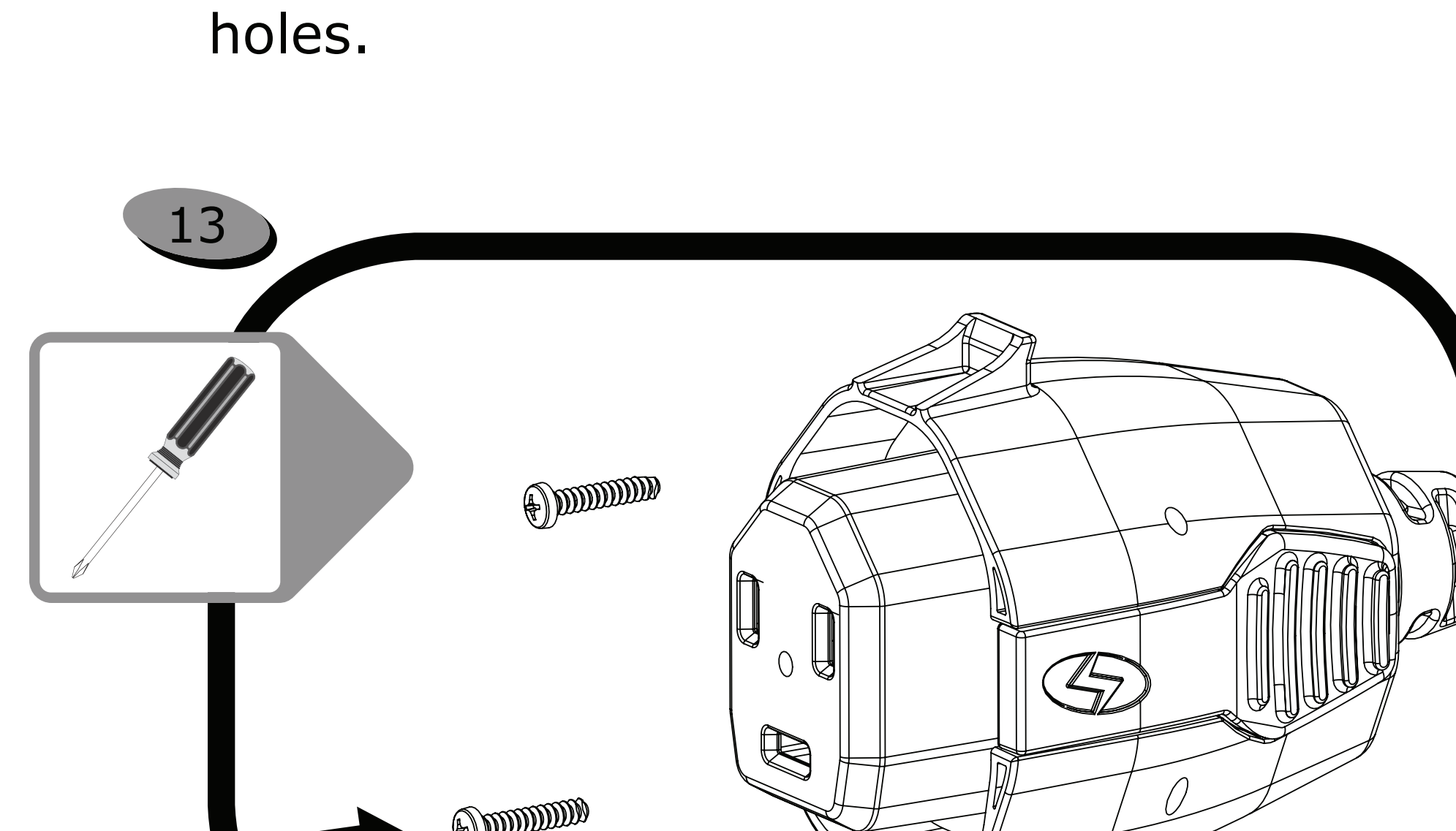

Locate and install (3) #6x1" screws (included) into corresponding inlet holes as shown. Use Philip's #2 and carefully screw components together by hand only. Do not over tighten. Max torque is: 1.4Kgf/cm².

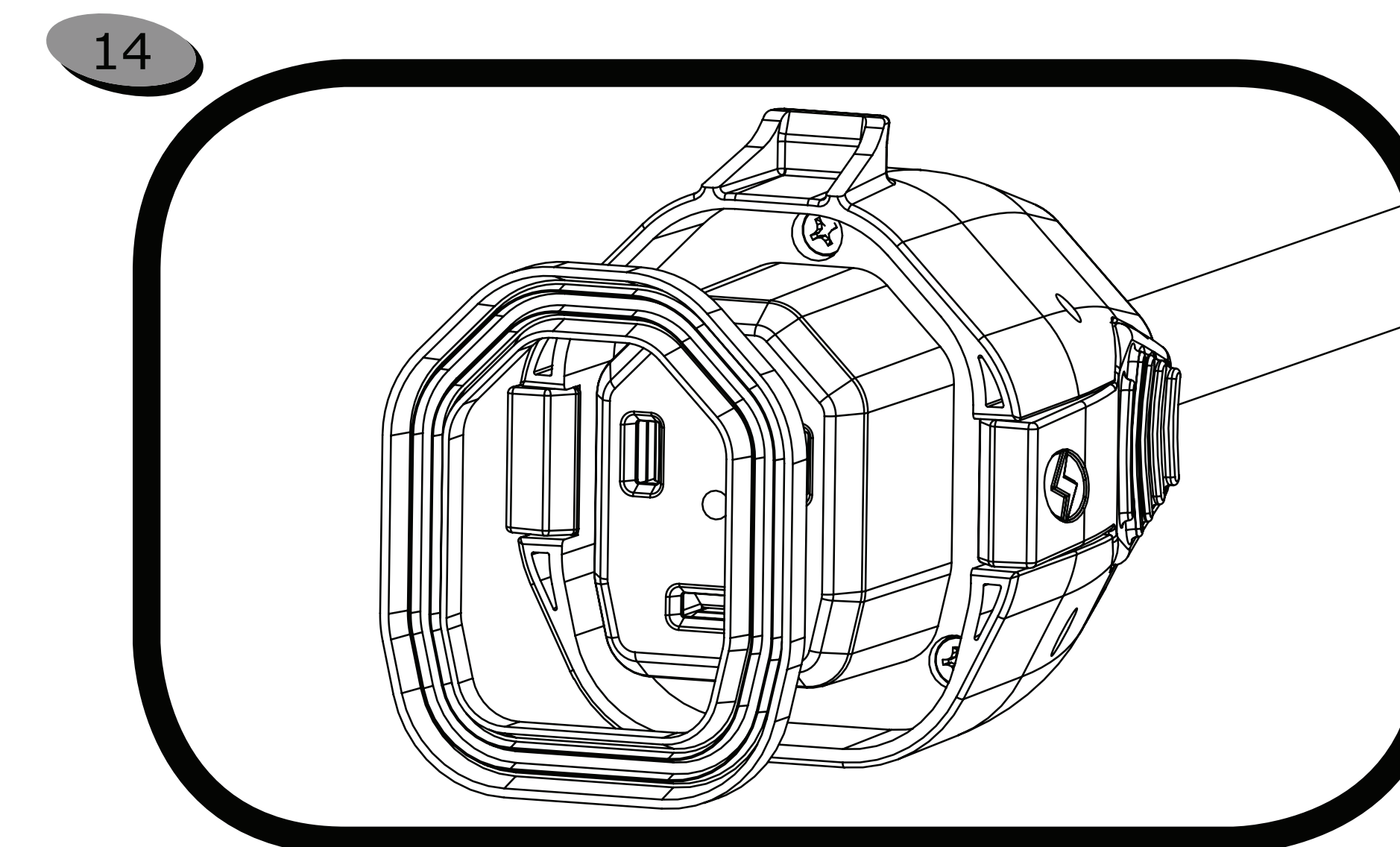

Remove adhesive backing from seal and slip over the plug face as shown. Use blunt tool and continue pushing seal into assembly until it seats and adheres fully. Check for any deformation of seal and adjust to fit.

Materials Included

A. SmartPlug Face (1)		
B. SmartPlug Body (1)		
C. Rubber Cord Gasket (2)		
D. Conical Install Tool (1)		
E. #6x25mm Screw (4)		
F. #6x19mm Screw (2)		
G. Face Seal (1)		
H. Hex Key (1)		