

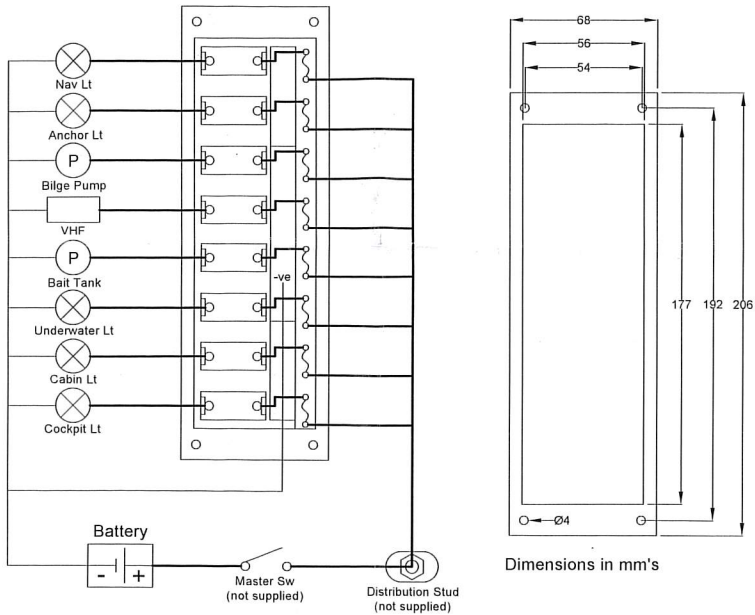

WATERPROOF SWITCH PANEL

Installation instructions for 8 way switch panel

1. Cut hole as per template (56mm x 177mm). Use 4 screws supplied to retain panel.
 2. Connect positive wires to positive distribution bar (not supplied).
 3. Connect negative wire to negative distribution bar (not supplied).
 4. Connect positive from appliance to piggy-back terminal on selected switch.
 5. Insert required fuse into selected cavity behind nylon cover.
 6. To replace blown fuses, remove nylon cover using a screw driver.
- Note: Maximum fuse rating is 15 amps. Rated for 12V DC only.



Dimensions in mm's

Connex Product Warranty

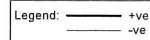

Our Product Guarantee

Connexwire stands behind its products for as long as you own them. Connexwire Limited will replace or issue a credit for any of its products found to be defective in materials or manufacture. No compensation will be allowed for products not returned to Connexwire for analysis, nor will compensation be made for labour required to replace any defective product. Please contact info@connexwire.com for a product return reference prior to shipping any product back to Connexwire.