

Contents

EU Regulatory Conformance.....2

Waterproof Design Warning.....3

Installation and charging.....3

RT411+ KEYS LOCATION DESCRIPTION4

A.KEY FUNCTION5

 A.1 Key Arrangement5

 A.2 LCD.....5

B. DIRECT KEY OPERATION6

 B.1 Power ON/OFF (Hardware)6

 B.2 VOL/SQL KEY6

 B.3 Turn the Key Beep sound off.....6

 B.4 UP/DOWN6

 B.5 16/9 Channel6

 B.6 H/M/L/LOCK Key7

 B.7 Private Channel7

 B.8 WX Channel(Only available for USA,Canada)7

 B.9 UIC Band7

 B.10 SCAN.....7

 B.11 MEM.....8

 B.12 Watch.....9

 B.13 Back Light9

C.SPECIAL FUNCTION OPERATION.....9

 C.1 TX time out9

 C.2 Power save Mode9

 C.3 TX Indicator9

 C.4 BEEP Adjustment9

D. EUROPEAN KEY OPERATION.....10

 D.1 Programming ATIS ID10

 D.2 Special Function Keys.....11

Appendix A – Near Lightning Strike Test.....11

Appendix B – Channel List12

 International Marine VHF Channels and Frequencies.....12

 U.S. Marine VHF Channels and Frequencies14

 Canadian Marine VHF Channels and Frequencies16

 European Private Channels and Frequencies.....19

 Weather Channels and Frequencies19

 Specifications20

RT411+ User Manual

Utility Model Hand-held Marine Radio with China Exclusive Patent Technology

EU Regulatory Conformance

As certified by the qualified laboratory, the product is in compliance with the essential requirements and other relevant provisions of the Directive 1999/5/EC. Please note that the above information is applicable to EU countries only.

Caution

1. The device can only receive signals when in charging mode.
2. Risk of explosion if battery is replaced by an incorrect type. Dispose of used batteries according to the instructions.
3. Adapter shall be installed near the equipment and shall be easily accessible.
4. The device operating temperature range is -20~55°C.
5. The plug considered as disconnect device of adapter.
6. The device complies with RF specifications when the device used at 25mm from your front face and 0mm from your body.
7. Declaration of Conformity.

The information listed above provides the user with information needed to make him or her aware of a RF exposure, and what to do to assure that this radio operates within the CE exposure limits of this radio.

The device complies with RF specifications when the device used at 25mm from your front face and 0mm from your body. Third-party belt-clips, holsters, and similar accessories used by this device should not contain any metallic components. Body-worn accessories that do not meet these requirements may not comply with RF exposure requirements and should be avoided. Maximum SAR Value (10g): 1.99W/Kg.

Fabricant: HIMUNICATION

Numbel: 11005103

Adresse: 3rd Floor,Block C,Huafeng Second Industry Park,Hangcheng Road,Gushu,Xixiang town, Baoan District, Shenzhen,China

Importateur: NAVICOM

Numbel: SIRET 31812243900058

Adresse: 32 Rue Marcel Paul – ZA de Kerdroniou – 29000 Quimper

Hereby, NAVICOM declares that this Maritime Radio is in compliance with essential requirements and other relevant provisions of Directive 2014/53/EU.



Waterproof Design Warning:

This product is the IP67 waterproof design, in order to achieve the best performance, before the end-user use it, and please pay the highest attention for the following three points:

- 1, To tight the antenna because there is an O-ring at the bottom of antenna side
- 2, To rotate tightly the round socket cap because there is an O-ring design around the cap
- 3, Non-professionals can not disassemble the machine.

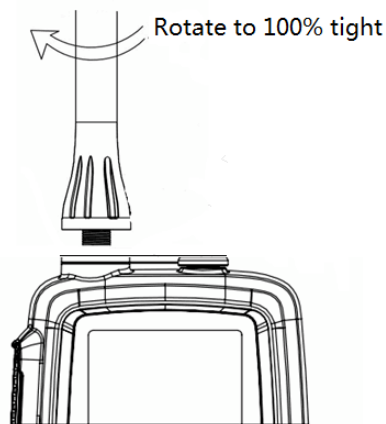

Installation and charging of the Li-Polymer battery pack

Place the battery on the device and secure it with the clip.

The battery pack can be charged when installed on the VHF, or separately on its supplied charger.

1. Insert the adapter connector into the charger.
2. Plug the adapter into a 220V socket.
3. Place the battery and VHF, installed on the VHF or separatly, on the base of charge.

Note: The battery pack charges only on its base. The connector on the top of the VHF connects a micro-headset.

RT-411+ KEYS LOCATION DESCRIPTION

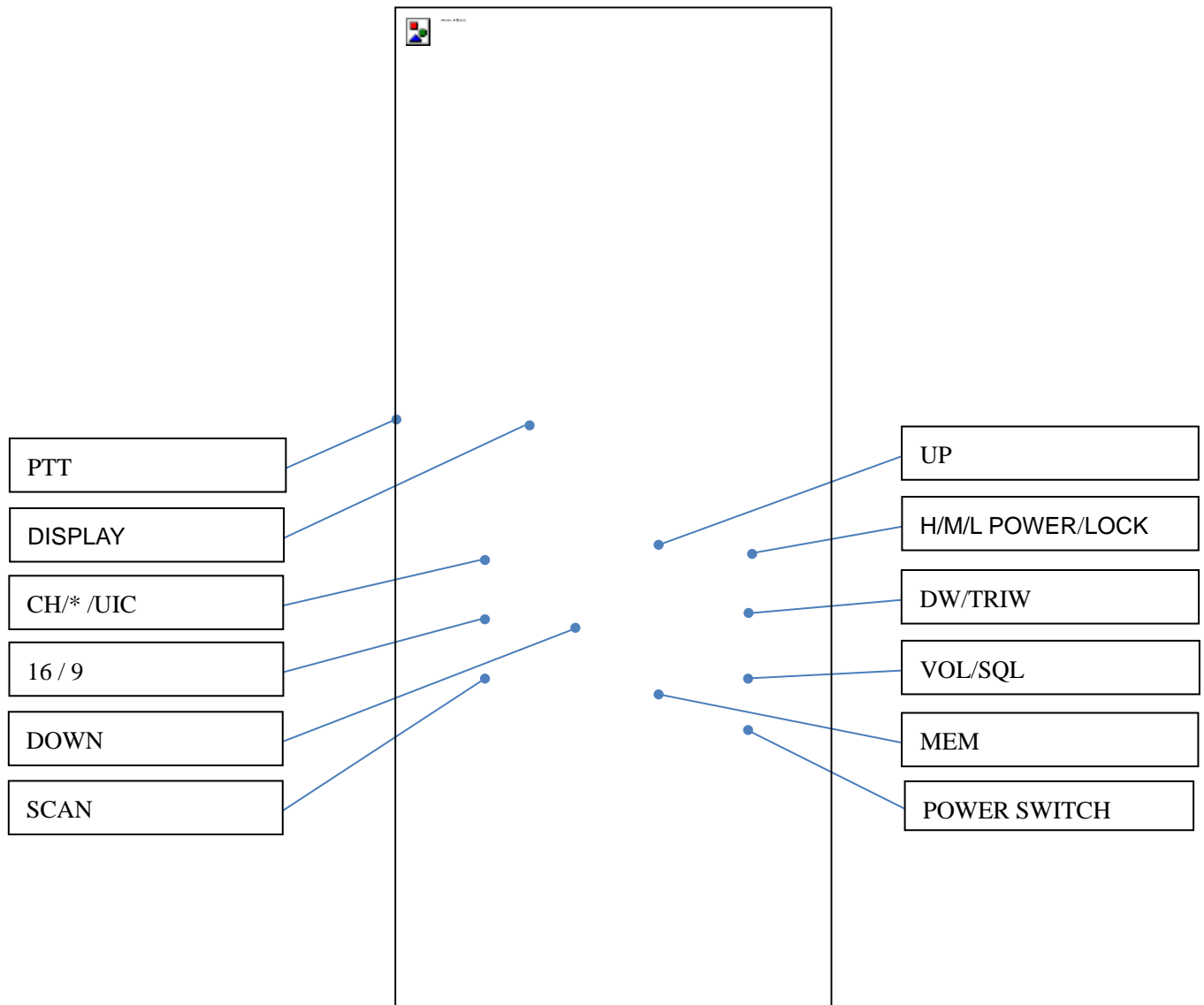

Caution:

- Risk of explosion if battery is replaced by an incorrect type. Dispose of used batteries according to the instructions.
- Adapter shall be installed near the equipment and shall be easily accessible.
- The plug considered as disconnect device of adapter.

A.KEY FUNCTION

Key	Short Press (< 3 sec)	Long Press (> 3 sec)
H/M/L /Lock	TX Power H/M/L /Lock	Lock Key
16/9	CH16	CH09
DW/TRIW	Dual Watch mode	Tri Watch mode
Power Switch	On	Off
SCAN	All Scan/all memory Scan	Priority all/memory Scan
MEM	MEMORY Mode	Save/Delete Memory Channel
Up/Down	Channel/ Setting Up/Down	Channel Fast up/Fast down
CH*/UIC	Private channel	Band Selection
VOL/SQL	SQL Set	

A.1 Key Arrangement

PTT	CH*/UIC	UP	H/M/L/LOCK
	16/9	DOWN	DW/TRIW
	SCAN	MEM	VOL/SQL
			POWER SWITCH

A.2 LCD

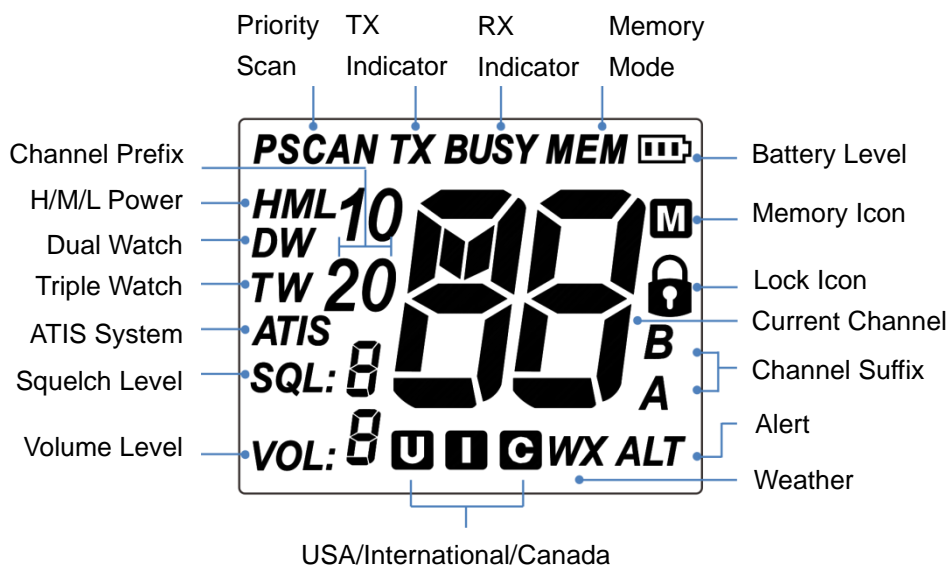

B. DIRECT KEY OPERATION

B.1 Power ON/OFF (Hardware)

Long press power switch to start normal operation mode, long press again will power down.

B.2 VOL/SQL KEY

Short press VOL/SQL key to adjust volume level,press UP/DOWN key to select volume level accordingly.Long press VOL/SQL key will flash squelch level,press UP/DOWN key to select squelch level accordingly.

B.3 Turn the Key Beep sound off

Hold on the SQL key to switch on then the Key Beep will be stop, conversely...do the same way again then the Key Beep will back.

B.4 UP/DOWN

At the normal mode, they act as Channel Up/Down. When it press > 0.5 sec, the unit will start to scrolls through the channels at 125ms intervals. It returns to normal mode when key press is released

B.5 16/9 Channel

Summary of CH16/9 Key operation:

- If current channel was not priority channel,press 16/9 key will directly jump to 16 channel or 9 channel(short press to jump to priority CH16 at High Power and long press to jump to priority CH9 at High Power)
Note: Accessing the priority channel will change the power setting to high power. The user can change the power setting to low power by pressing H/M/L/LOCK Key. If the priority channel is limited by the cloning software for 1-W only, accessing priority channel will still follow the low power limitation.
- After the channel is tuned to the priority channel, the “P” icon is lit to indicate that the priority CH16 or CH9 has been reached. UP and Down key functions normally
- When the radio already tunes to the priority channel ,pressing 16/9 key will revert radio to the previously used working channel depending on how it being press (see flow chart above).

16/9 Key also act ‘esc key’ to exit other modes

To reprogram a secondary priority channel:

- Tune to priority CH9. It is indicated by “P” icon. It is done by pressing “16/9” key for more than 3 seconds.
- Then, press and hold the “16/9” key for 3 seconds.
- and Currently secondary priority channel number should start flashing and the current secondary priority channel number should start flashing.

- While the channel number is flash,it can be changed with“UP”and“DOWN”arrow buttons.The selection can be saved by short pressing “16/9” key and the screen display “P” icon to indicate that the secondary priority channel has been changed.
- The user can reprogram the secondary priority channel on the RT411+

B.6 Hi/Lo/LOCK Key

Short press Hi/LO/LOCK Key will toggle the TX power from H to M or L , corresponding H to M or L icon will display on the LCD.

Some of channels has been limited to be low power only or high power only. Thus, the software needs to check against the channel setting stored in the EEPROM.

If the operation request is denied,error beeps tone will out.

All keypad will be locked except PTT key by pressing Hi/LO/LOCK Key more than 3 seconds, correspondingly the "lock icon "will display on the LCD,press Hi/LO/LOCK Key again more than 3 seconds will release the key lock function

B.7 Private Channel

Shore press CH*/UIC enter into private channel mode,switch it by press UP/DOWN key.If private channel didn't exist,it will display"--" .

B.8 WX Channel(Only available for USA,Canada)

Short press WX*/UIC key will enter WX mode. Press Up/Down key to change WX channel. Long press WX*/UIC key to enable and detect weather alarm,if the alert tone is detected, the "ALT" symbol should flash in the screen,long press WX*/UIC again to cancel weather alarm,"ALT" symbol will disappear accordingly.

B.9 UIC Band

Long press CH*/UIC to switch operational channel band(USA,INT and CAN).When band was switched,the band sequence will change accordingly.

Noted:If one frequency was programmed to this radio device,activating this function will generate wrong alarm.

B.10 SCAN

This is the function to scan for broadcasting channels. When available channel detected, the receiver will stop at that channel and continue to search when that transmission ceased.

There are 4 Scan modes available – All SCAN, Memory Scan,Priority Scan & memory Scan, Default is All Scan

- 1、 At the normal mode,short press the SCAN key to activate SCAN function.
- 2、 When the radio in the normal mode, All Scan will be initiated. When the radio in the All Scan mode, all channel will be scan in sequence.
- 3、 When the radio in the memory mode, short press SCAN key to initiate Memory Scan,will be . long press the Scan key will initiate Priority Scan.

During scan,long press SCAN key will activate All Scan or Memory Scan."p" icon (priority icon)will lit

The memory channel will be stated whenever signal received. Once the transmission finished, the SCAN will automatically carry on to searching for next channel.

All Memory Scan

M1 – M2 – M3 - ... M10 – M1- ...

All Scan

CH1-CH2-CH3-.....-CH88-CH1

Priority Memory Scan

M1 – CH 16 – M2 – CH 16 - ... CH 16 – M1 – M16 - ...

(M1; M2; M3 means 1st, 2nd, 3rd programmed channel)

Priority All Scan

CH1-CH16-CH2-CH16-CH3-CH16-.....CH88-CH16-L1-CH16-...

(The radio only has L1 as its private channel)

B.11 MEM

Press the MEM to enter the memory mode when there is at least one channel in the memory. The channel sequences will follow the programmed channels in the memory. The "MEM" icon will be turned on. Short press the SCAN will start MEMORY SCAN

Adding CH from the memory:

1. During the normal mode, use the UP/DOWN key to select the desired channel for programming.
2. Long press the MEM key to store up the channel as memory channel.The "M" icon shows up to indicate the current channel has been saved in the memory. No limited of memory channels.
3. Separate memory channel exists for USA, International, and Canadian Frequency group.

Deleting CH from the memory:

1. 1.During the normal mode, use the UP/DOWN key to select the channel to be deleted.
2. 2.Long press the MEM key to delete the channel from the memory.'M' icon will disappear

B.12 Watch

Dual Watch

Short press DW/TRIW key to activate the DUAL WATCH mode. Monitor the current channel and Ch 16 in cycle.

TRI Watch

Long press DW/TRI key to activate the TRI WATCH mode. Monitor the Ch 16, current channel and the 2nd Priority CH in cycle.

Programmable channel is CH9 by default.

Note: programmed channel is the secondary priority Channel. Current Channel – CH 16 – 2nd Priority CH – Current Channel – CH 16 – 2nd Priority CH – Current Channel - ...

B.13 Back Light

Any key press will turn on the back light (if back-light setting is ON) except the PTT key. The back-light should be remaining on for 3 sec if no any keys pressed. The time out will be reset if any key pressed within the time frame except PTT key. If back-light is on, press 'PTT' key will turn off back-light

C.SPECIAL FUNCTION OPERATION

C.1 TX time out

The transmission will be automatically turn off after PTT key pressed over 3 consecutive minutes. The TX mode will be terminate and back to Rx mode. Once the PTT key is released, the TX time out timer will be reset. PTT key will work back normally.

C.2 Power save Mode

Normal Mode
100ms ON, 300ms OFF

C.3 TX Indicator

When the radio is transmitting, the "TX" icon will be lit up.

C.4 BEEP Adjustment

The radio features BEEP by default. However, you can choose switch on/off BEEP. Power off radio when radio is on, press POWER key as well as SQL/VOL key to start up radio, the BEEP by default will switch off.

If you want BEEP return to original setting. Just power off, then press POWER key as well as SQL/VOL key to start up radio again, then it will work, means BEEP will switch on.

D. EUROPEAN KEY OPERATION

Most of the functions in the radio are the same as the US model. These are the functions that work differently.

D.1 Programming ATIS ID

ATIS function only exists in European Model. Therefore, it only functions when the European radio is tuned to the International Frequency Group. After ATIS ID is being programmed into the radio via the keypad or the cloning software, the ATIS function will be enabled all the time. The user cannot disable it.

To enable the customer to enter ATIS ID into the radio from the keypad, the check box next to the ATIS entry by user on the Cloning software has to be ticked.

Programming ATIS ID from the Keypad

- Programming start with the radio turn OFF.
- Long press DOWN and turn radio ON to access the ATIS mode.
- The front digit will indicate the digit position of the ATIS ID. The rear digit will blink continuously. The rear digit indicates the ATIS ID. Changing the value of the rear digit can be achieved using the "UP/DOWN" Key.
- Press "MEM" key to confirm the selection and move to the next digit.
- After the user complete the 9 digit ATIS ID, the user has to enter the ATIS ID the second time to avoid invalid entry. If different ATIS ID is entered, operation will be canceled. The user has to repeat step one to initiate the ATIS ID entering sequence.
- The operating procedure to enter a valid ATIS ID for the second time is same as the first time, the ATIS ID will be flashed in sequence one time on the screen.
- Turn off radio, permanently save ATIS ID to the EEPROM of the radio.
- After the ATIS ID being programmed into the radio, from OFF position holding DOWN and turning the radio ON will make the radio flash its ATIS ID. After this stage, only with the cloning software the ATIS ID be modified or erased.
- At the ATIS mode, part of international channels are restricted to transmit on low-power, such as CH6, CH8, CH10, CH11, CH12, CH13, CH14, CH71, CH72, CH74, CH77.

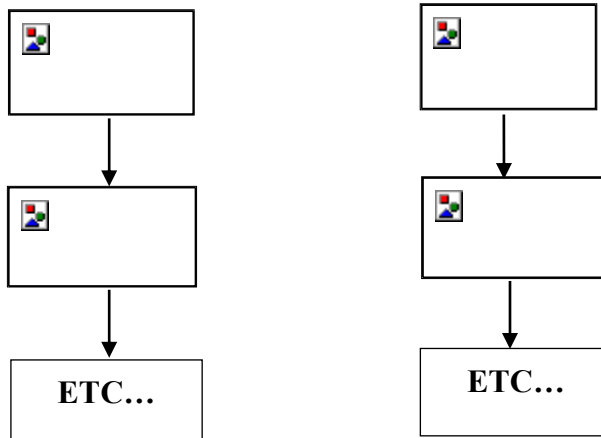

D.2 Special Function Keys

Press DW/TRIW key as well as power key to directly enter into write channel mode as below displayed.

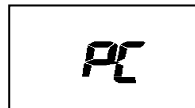

Appendix A – Near Lightning Strike Test

This appendix describes the general procedure for evaluating the immunity to near lightning strikes (NLS) of the RT411+ VHF Radio.

The test simulates a slow, high-energy pulse produced by an NLS event. Relative external document as below

List of Abbreviations

AE	Auxiliary Equipment
CE	Conducted Emissions
EMC	Electromagnetic Compatibility
EN	European Norm
EUT	Equipment Under Test
FTB	Fast Transient Burst
MED	Marine Equipment Directive
QP	Quasi Peak

Safety

The high voltage interference pulse can contain a very large quantity of energy and every precaution shall be taken to avoid contact with EUT during a test. It is highly recommended that at least one other person is present (or very close by) during the test.

Test Configuration

EUT Configuration

All operating configurations should be tested with appropriate performance criteria defined for each test.

Appendix B – Channel List

International Marine VHF Channels & Frequencies				
CH	TX Freq	RX Freq	Simplex	Freq Use
1	156.050	160.650		Public Correspondence, Port Operations and Ship Movement
2	156.100	160.700		Public Correspondence, Port Operations and Ship Movement
3	156.150	160.750		Public Correspondence, Port Operations and Ship Movement
4	156.200	160.800		Public Correspondence, Port Operations and Ship Movement
5	156.250	160.850		Public Correspondence, Port Operations and Ship Movement
6	156.300	156.300	x	Inter-ship [1]
7	156.350	160.950		Public Correspondence, Port Operations and Ship Movement
8	156.400	156.400	x	Inter-ship
9	156.450	156.450	x	Inter-ship, Port Operations and Ship Movement
10	156.500	156.500	x	Inter-ship, Port Operations and Ship Movement [2]
11	156.550	156.550	x	Port Operations and Ship Movement
12	156.600	156.600	x	Port Operations and Ship Movement
13	156.650	156.650	x	Inter-ship Safety, Port Operations and Ship Movement [3]
14	156.700	156.700	x	Port Operations and Ship Movement
15	156.750	156.750	x	Inter-ship and On-board Communications at 1W only [4]
16	156.800	156.800	x	Distress, Safety and Calling
17	156.850	156.850	x	Inter-ship and On-board Communications at 1W only [4]
18	156.900	161.500		Public Correspondence, Port Operations and Ship Movement
19	156.950	161.550		Public Correspondence, Port Operations and Ship Movement
1019	156.950	156.950		Public Correspondence, Port Operations and Ship Movement
2019	161.550	161.550		Public Correspondence, Port Operations and Ship Movement
20	157.000	161.600		Public Correspondence, Port Operations and Ship Movement
1020	157.000	157.000		Public Correspondence, Port Operations and Ship Movement
2020	161.600	161.600		Public Correspondence, Port Operations and Ship Movement
21	157.050	161.650		Public Correspondence, Port Operations and Ship Movement
22	157.100	161.700		Public Correspondence, Port Operations and Ship Movement
23	157.150	161.750		Public Correspondence, Port Operations and Ship Movement
24	157.200	161.800		Public Correspondence, Port Operations and Ship Movement
25	157.250	161.850		Public Correspondence, Port Operations and Ship Movement
26	157.300	161.900		Public Correspondence, Port Operations and Ship Movement
27	157.350	161.950		Public Correspondence, Port Operations and Ship Movement
28	157.400	162.000		Public Correspondence, Port Operations and Ship Movement
60	156.025	160.625		Public Correspondence, Port Operations and Ship Movement
61	156.075	160.675		Public Correspondence, Port Operations and Ship Movement
62	156.125	160.725		Public Correspondence, Port Operations and Ship Movement
63	156.175	160.775		Public Correspondence, Port Operations and Ship Movement
64	156.225	160.825		Public Correspondence, Port Operations and Ship Movement
65	156.275	160.875		Public Correspondence, Port Operations and Ship Movement
65A	156.275	156.275		Non-Commercial
66	156.325	160.925		Public Correspondence, Port Operations and Ship Movement

66A	156.325	156.325		Non-Commercial
67	156.375	156.375	x	Inter-ship, Port Operations and Ship Movement [2]
68	156.425	156.425	x	Port Operations and Ship Movement
69	156.475	156.475	x	Inter-ship, Port Operations and Ship Movement
71	156.575	156.575	x	Port Operations and Ship Movement
72	156.625	156.625	x	Inter-ship
73	156.675	156.675	x	Inter-ship [2]
74	156.725	156.725	x	Port operations and Ship movement
75	156.775	156.775	x	See Note [5]
76	156.825	156.825	x	See Note [5]
77	156.875	156.875	x	Inter-ship
78	156.925	161.525		Public correspondence, Port Operations and Ship Movement
1078	156.925	156.925		Public correspondence, Port Operations and Ship Movement
2078	161.525	161.525		Public correspondence, Port Operations and Ship Movement
79	156.975	161.575		Public correspondence, Port Operations and Ship Movement
1079	156.975	156.975		Public correspondence, Port Operations and Ship Movement
2079	161.575	161.575		Public correspondence, Port Operations and Ship Movement
80	157.025	161.625		Public correspondence, Port Operations and Ship Movement
81	157.075	161.675		Public correspondence, Port Operations and Ship Movement
82	157.125	161.725		Public correspondence, Port Operations and Ship Movement
83	157.175	161.775		Public correspondence, Port Operations and Ship Movement
84	157.225	161.825		Public correspondence, Port Operations and Ship Movement
85	157.275	161.875		Public correspondence, Port Operations and Ship Movement
86	157.325	161.925		Public correspondence, Port Operations and Ship Movement
87	157.375	157.375	x	Port Operations and Ship Movement
88	157.425	157.425	x	Port Operations and Ship Movement

- ◆ Inter-ship channels are for communications between ship stations. Inter-ship communications should be restricted to Channels 6, 8, 72 and 77. If these are not available, the other channels marked for Inter-ship may be used.
- ◆ Channel 70 is used exclusively for Digital Selective Calling (DSC) and is not available for regular voice communications.

Notes:

1. Channel 06 may also be used for communications between ship stations and aircraft engaged in coordinated search and rescue operations. Ship stations should avoid harmful interference to such communications on channel 06 as well as to communications between aircraft stations, ice breakers and assisted ships during ice seasons.
2. Within the European Maritime Area and in Canada, channels 10, 67 and 73 may also be used by the individual administrations concerned for communication between ship stations, aircraft stations and participating land stations engaged in coordinated search and rescue and anti-pollution operations in local areas. Channels 10 or 73 (depending on location) are also used for the broadcast of Marine Safety Information by the Maritime and Coast Guard Agency in the UK only.
3. Channel 13 is designated for use on a worldwide basis as a navigation safety communication channel, primarily for inter-ship navigation safety communications.
4. Channels 15 and 17 may also be used for on-board communications provided the effective radiated power does not exceed 1 Watt.
5. The use of Channels 75 and 76 should be restricted to navigation related communication only and all precautions should be taken to avoid harmful interference to channel 16. Transmit power is limited to 1 Watt.

U.S. Marine VHF Channels and Frequencies				
CH	TX Freq	RX Freq	Simplex	Freq Use
01A	156.050	156.050	x	Port Operations and Commercial, VTS. Available only in New Orleans / Lower Mississippi area.
03A	156.150	156.150	x	U.S. Government only
05A	156.250	156.250	x	Port Operations or VTS in the Houston, New Orleans and Seattle areas.
6	156.300	156.300	x	Inter-ship Safety
07A	156.350	156.350	x	Commercial
8	156.400	156.400	x	Commercial (Inter-ship only)
9	156.450	156.450	x	Boater Calling. Commercial and Non-Commercial.
10	156.500	156.500	x	Commercial
11	156.550	156.550	x	Commercial. VTS in selected areas.
12	156.600	156.600	x	Port Operations. VTS in selected areas.
13	156.650	156.650	x	Inter-ship Navigation Safety (Bridge-to-bridge). Ships >20meters in length maintain a listening watch on this channel in US waters.
14	156.700	156.700	x	Port Operations. VTS in selected areas.
15	–	156.750	x	Environmental (Receive only). Used by Class ‘C’ EPIRBS.
16	156.800	156.800	x	International Distress, Safety and Calling. Ships required to carry radio, USCG, and most coast stations maintain a listening watch on this channel.
17	156.850	156.850	x	State Control
18A	156.900	156.900	x	Commercial
19A	156.950	156.950	x	Commercial
20	157.000	161.600		Port Operations (duplex)
20A	157.000	157.000	x	Port Operations
21A	157.050	157.050	x	U.S. Coast Guard only
22A	157.100	157.100	x	Coast Guard Liaison and Maritime Safety Information Broadcasts. Broadcasts announced on channel 16.
23A	157.150	157.150	x	U.S. Coast Guard only
24	157.200	161.800		Public Correspondence (Marine Operator)
25	157.250	161.850		Public Correspondence (Marine Operator)
26	157.300	161.900		Public Correspondence (Marine Operator)
27	157.350	161.950		Public Correspondence (Marine Operator)
28	157.400	162.000		Public Correspondence (Marine Operator)
61A	156.075	156.075	x	U.S. Government only
63A	156.175	156.175	x	Port Operations and Commercial, VTS. Available only in New Orleans / Lower Mississippi area.
64A	156.225	156.225	x	U.S. Coast Guard only
65A	156.275	156.275	x	Port Operations
66A	156.325	156.325	x	Port Operations

67	156.375	156.375	x	Commercial. Used for Bridge-to-bridge communications in lower Mississippi River. Inter-ship only.
68	156.425	156.425	x	Non-Commercial
69	156.475	156.475	x	Non-Commercial
70	156.525	156.525	x	Non-Commercial
71	156.575	156.575	x	Non-Commercial
72	156.625	156.625	x	Non-Commercial (Inter-ship only)
73	156.675	156.675	x	Port Operations
74	156.725	156.725	x	Port Operations
77	156.875	156.875	x	Port Operations (Inter-ship only)
78A	156.925	156.925	x	Non-Commercial
79A	156.975	156.975	x	Commercial. Non-Commercial in Great Lakes only.
80A	157.025	157.025	x	Commercial. Non-Commercial in Great Lakes only
81A	157.075	157.075	x	U.S. Government only – Environmental protection operations.
82A	157.125	157.125	x	U.S. Government only
83A	157.175	157.175	x	U.S. Coast Guard only
84	157.225	161.825		Public Correspondence (Marine Operator)
84A	157.225	157.225		Non-Commercial
85	157.275	161.875		Public Correspondence (Marine Operator)
85A	157.275	157.275		Non-Commercial
86	157.325	161.925		Public Correspondence (Marine Operator)
86A	157.325	157.325		Non-Commercial
87	157.375	161.975		Public Correspondence Marine Operator)
87A	157.375	157.375		Non-Commercial
88	157.425	162.025		Public Correspondence only near Canadian border
88A	157.425	157.425	x	Commercial, Inter-ship only

- ◆ Recreational boaters normally use channels listed as Non-Commercial: 68, 69, 71, 72, 78A.
- ◆ Channel 70 is used exclusively for Digital Selective Calling (DSC) and is not available for regular voice communications.
- ◆ Channels 75 and 76 are reserved as guard bands for Channel 16 and are not available for regular voice communications.

Notes:

1. The letter “A” following a channel number indicates simplex use of the ship station transmit side of an international semi-duplex channel. Operations are different from that of international operations on that channel.
2. Channel 13 should be used to contact a ship when there is danger of collision. All ships of length 20 meters or greater are required to guard VHF channel 13, in addition to VHF channel 16, when operating within U.S. territorial waters.
3. Channel is Receive Only.
4. Channel 16 is used for calling other stations or for distress alerting.
5. Output power is fixed at 1 watt only.
6. Output power is initially set to 1 watt. User can temporarily override this restriction to transmit at high power.

Canadian Marine VHF Channels and Frequencies

CH	TX Freq	RX Freq	Area of Operation Use
1	156.050	160.650	PC Public Correspondence
2	156.100	160.700	PC Public Correspondence
3	156.150	160.750	PC Public Correspondence
04A	156.200	156.200	PC Inter-ship, Ship/Shore and Safety: Canadian Coast Guard S&R
05A	156.250	156.250	Ship Movement
6	156.300	156.300	All areas Inter-ship, Commercial, Non commercial and Safety: May Be used for search and rescue communications between ships and aircraft.
07A	156.350	156.350	All areas Inter-ship, Ship/Shore, Commercial
8	156.400	156.400	WC, EC Inter ship, Commercial and Safety: Also assigned for operations in the Lake Winnipeg area.
9	156.450	156.450	AC Inter-ship, Ship/Shore, Commercial, Non-commercial and Ship Movement: May be used to communicate with aircraft and Helicopters in predominantly maritime support operations.
10	156.500	156.500	AC, GL Inter-ship, Ship/Shore, Commercial, Non-commercial, Safety and Ship Movement: May also be used for communications with aircraft engaged in coordinated search and rescue and antipollution operations.
11	156.550	156.550	PC, AC, GL Inter-ship, Ship/Shore, Commercial, Non-commercial and Ship Movement: Also used for pilotage purposes.
12	156.600	156.600	WC, AC, GL Inter-ship, Ship/Shore, Commercial, Non-commercial and Ship Movement: Port operations and pilot information and messages.
13	156.650	156.650	All areas Inter-ship, Commercial, Non-commercial and Ship Movement: Exclusively for bridge-to-bridge navigational traffic. Limited to 1-watt maximum power.
14	156.700	156.700	AC, GL Inter-ship, Ship/Shore, Commercial, Non-commercial and Ship Movement: Port operations and pilot information and Messages.
15	156.750	156.750	All areas Inter-ship, Ship/Shore, Commercial, Non-commercial and Ship Movement: All May also be used for on-board Communications.
16	156.800	156.800	All areas International Distress, Safety and Calling.
17	156.850	156.850	All areas Inter-ship, Ship/Shore, Commercial, Non-commercial and Ship Movement: All operations limited to 1-watt maximum power. May also be used for on-board Communications.
18A	156.900	156.900	All areas Inter-ship, Ship/Shore and Commercial: Towing on the Pacific Coast.
19A	156.950	156.950	All areas except PC Inter-ship and Ship/Shore: Canadian Coast Guard only.
20	157.000	161.600	All areas Ship/Shore, Safety and Ship Movement: Port operation

21A	157.050	157.050	All areas Inter-ship and Ship/Shore: Canadian Coast Guard only.
21B	—	161.650	All areas Safety: Continuous Marine Broadcast (CMB) service.
22A	157.100	157.100	All areas Inter-ship, Ship/Shore, Commercial and Non-commercial: For communications between Canadian Coast Guard and non-Canadian Coast Guard stations only.
23	157.150	161.750	PC Ship/Shore and Public Correspondence: Also in the inland waters of British Columbia and the Yukon.
23B	—	161.750	Continuous Marine Broadcast Service
24	157.200	161.800	All areas Ship/Shore and Public Correspondence
25	157.250	161.850	PC Ship/Shore and Public Correspondence: Also assigned for operations in the Lake Winnipeg area.
25B	—	161.850	AC Safety: Continuous Marine Broadcast (CMB) service.
26	157.300	161.900	All areas Ship/Shore, Safety and Public Correspondence
27	157.350	161.950	AC, GL, PC Ship/Shore and Public Correspondence
28	157.400	162.000	PC Ship/Shore, Safety and Public Correspondence
28B	—	162.000	AC Safety: Continuous Marine Broadcast (CMB) service.
60	156.025	160.625	PC Ship/Shore and Public Correspondence.
61A	156.075	156.075	EC Inter-ship, Ship/Shore and Commercial: Commercial fishing only.
62A	156.125	156.125	EC Inter-ship, Ship/Shore and Commercial: Commercial fishing only.
63A	156.175	156.175	Tow Boats - BCC area
64	156.225	160.825	PC Ship/Shore and Public Correspondence
64A	156.225	156.225	EC Inter-ship, Ship/Shore and Commercial: Commercial fishing only.
65A	156.275	156.275	Inter-ship, Ship/Shore, Commercial, Non-commercial, Safety: Search & rescue and antipollution operations on the Great Lakes. Towing on the Pacific Coast. Port operations only in the St. Lawrence River areas with 1W maximum power. Pleasure craft in the inland waters of Alberta, Saskatchewan and Manitoba (excluding Lake Winnipeg and the Red River).
66A	156.325	156.325	Inter-ship, Ship/Shore, Commercial, Non-commercial, Safety and Ship Movement:Port operations only in the St.Lawrence River/Great Lakes Areas with 1-watt maximum power.
67	156.375	156.375	All areas except EC Inter-ship, Ship/Shore, Commercial, Non-commercial, Safety:May also be used for communications with aircraft engaged in coordinated search and rescue and antipollution operations.
68	156.425	156.425	All areas Inter-ship, Ship/Shore and Non-commercial: For marinas and yacht clubs.

69	156.475	156.475	All areas except EC Inter-ship, Ship/Shore, Commercial and Non-commercial
71	156.575	156.575	PC Inter-ship, Ship/Shore, Commercial, Non-commercial, Safety and Ship Movement the East Coast and on Lake Winnipeg.
72	156.625	156.625	EC, PC Inter-ship, Commercial and Non-commercial: May be used to communicate with aircraft and helicopters in predominantly maritime support
73	156.675	156.675	All areas except EC Inter-ship, Ship/Shore, Commercial, Non-commercial, Safety: May also be used for communications with aircraft engaged in coordinated search and rescue and antipollution operations.
74	156.725	156.725	EC, PC Inter-ship, Ship/Shore, Commercial, Non-commercial and Ship Movement.
75	156.775	156.775	Simplex port operation, Ship movement and navigation related communication only. 1 watt maximum
76	156.825	156.825	Simplex port operation, Ship movement and navigation related communication only. 1 watt maximum
77	156.875	156.875	Inter-ship, Ship/Shore, Safety and Ship Movement: Pilotage on Pacific Coast. Port operations only in the St. Lawrence River/Great Lakes areas with 1W maximum power.
78A	156.925	156.925	EC, PC Inter-ship, Ship/Shore and Commercial
79A	156.975	156.975	EC, PC Inter-ship, Ship/Shore and Commercial
80A	157.025	157.025	EC, PC Inter-ship, Ship/Shore and Commercial
81A	157.075	157.075	Inter-ship and Ship/Shore: Canadian Coast Guard use only in the St. Lawrence River/ Great Lakes areas.
82A	157.125	157.125	Inter-ship and Ship/Shore: Canadian Coast Guard use only in the St. Lawrence River/ Great Lakes areas.
83A	157.175	157.175	EC Inter-ship and Ship/Shore: Canadian Coast Guard and other Government agencies.
83B	–	161.775	AC, GL Safety: Continuous Marine Broadcast (CMB) Service.
84	157.225	161.825	PC Ship/Shore and Public Correspondence
85	157.275	161.875	AC, GL, NL Ship/Shore and Public Correspondence
86	157.325	161.925	PC Ship/Shore and Public Correspondence
87	157.375	161.975	AC, GL, NL Ship/Shore and Public Correspondence
88	157.425	162.025	AC, GL, NL Ship/Shore and Public Correspondence

AC: Atlantic Coast, Gulf and St. Lawrence River up to and including Montreal

EC: (East Coast): includes NL, AC, GL and Eastern Arctic areas

GL: Great Lakes (including St. Lawrence above Montreal)

NL: Newfoundland and Labrador

PC: Pacific Coast

WC: (West Coast): Pacific Coast, Western Arctic and Athabasca-Mackenzie Watershed areas All areas: includes East and West Coast areas

Notes:

1. An "A" following a channel number indicates simplex use of the ship station transmit side of an international duplex channel. Operations are different from that of international operations on that channel.
2. Channel 16 is used for calling other stations or for distress alerting.
3. The letter "B" following a channel number indicates simplex use of the coast station transmit side of an international duplex channel. That is, the channel is Receive Only.
4. Channel 70 is used exclusively for Digital Selective Calling (DSC) and is not available for regular voice communications.

6. Channels 75 and 76 are reserved as guard bands for Channel 16 and are not available for regular voice communications.

European Private Channels and Frequencies

In addition to the channels listed above in the International Marine VHF Channels & Frequencies table, your radio may also include some of the following private channels. Which channels are included depend upon the country in which the radio is to be operated and whether you possess the appropriate licensing

Country	CH	TX Freq	RX Freq	Freq Use
Belgium	96	162.425	162.425	Marina
Denmark	L1	155.500	155.500	Leisure
	L2	155.525	155.525	Leisure
Denmark, Finland,	F1	155.625	155.625	Fishing
Norway & Sweden	F2	155.775	155.775	Fishing
	F3	155.825	155.825	Fishing
Finland, Norway&Sweden	L1	155.500	155.500	Leisure
	L2	155.525	155.525	Leisure
	L3	155.650	155.650	Leisure
Netherlands	31	157.550	162.150	Marina
	37	157.850	157.850	Leisure
UK	M1	157.850	157.850	Marina
	M2	161.425	161.425	Marina

Notes: A license may be required to operate the radio on the private channels. It is your responsibility to obtain the proper license to operate the radio on these frequencies.

Weather Channels and Frequencies

WX channel	Frequency(MHz)		Remarks
	Transmit	Receive	
1	RX only	162.550	Weather(receive only)
2	RX only	162.400	Weather(receive only)
3	RX only	162.475	Weather(receive only)
4	RX only	162.425	Weather(receive only)
5	RX only	162.450	Weather(receive only)
6	RX only	162.500	Weather(receive only)
7	RX only	162.525	Weather(receive only)
8	RX only	161.650	Weather(receive only)
9	RX only	161.775	Weather(receive only)
10	RX only	163.275	Weather(receive only)

SPECIFICATIONS

DESCRIPTION	Unit	LIMIT
Frequency Range:Transmit	MHz	156.025 To 157.425
Frequency Range:Receive	MHz	156.300 To 162.000
Number Of Channels		56 INT Channels
		52 USA Channels
		59 Canada Channels
		10 Weather Channels(only for USA)
		99 Private Channels
Oscillate Mode		PLL
Modulation		FM(16K0G3E)
Channel Spacing	KHz	25
Frequency Stability	PPM	±5
Standard Operation Temperature	°C	-20 ~ +55
Controls :Volume		Adjust by UP/DOWN Key
Channel		UP,DOWN Keys
SQL		SQL Key
Feature Keys		PTT
		CH*/UIC,UP,H/M/L/LOCK,16/9,DOWN, DW/TRI,SCAN,MEM,VOL/SQL
Normal Working Voltage	V	7.4V(With Li-Polymer Battery 1200mAh)
Low Limit Working Voltage	V	6.0
Battery Lifetime (Tx 5% / Rx 5% / Standby 90%)	H	≥10
Memory		EEPROM
Antenna Socket		SMA
Display		Segment Code LCD With White Back Light
Built-In Speaker		Diamter 40mm / Impedance 8 Ohm
Accessory :		Belt Clip
		Hand Strap
		Rubber Duck Antenna
		7.4V slide lock Li-Polymer Battery Pack (1200MAH)
		AC 100~240V / DC 12V Desktop charger (worldwide)
TRANSMITTER		
1.Carrier power(no mod)		
High power	W	6
Middle power	W	3
Low power	W	1
2.Carrier freq.Tolerance	ppm	±5
3.Max Modulation limiting	±KHz	5
4.Audio frequency response		
@300Hz	dB	-13.5~-9.5
@2000Hz	dB	3.0~7.0
@3000Hz	dB	+7.5~+10.5
5.Audio distortion @ 3 KHz Dev.	%	<5
6.Residual modulation	dB	≤-40
7.Mic sens.For 3KHz	mV	13±3
8.Conducted spurious emission	dBm	≤-36
9.Current drain		

Transmit(High)	A	≤1.6
Transmit(Middle)	A	≤1.2
Transmit(Low)	A	≤0.9
RECEIVER		
1.Sensitivity For 12dB Sinad	dBμV	≤-6(EMF)
2.Squelch		
a) squelch threshold	dBμV	<-6.0(EMF)
b) hysteresis	dB	3~6
c) squelch tight	dBμV	0dBuV ~ +6dBuV
3.Rated audio output		
@10% Thd Speaker	mW	≥1000
4.Max.S/N ratio @ 1mV	dB	≥40
5.Audio frequency resp.	dB	1000Hz/0dB ref.
@300Hz	dB	+7.5~+11.5
@2000Hz	dB	-9~-5
@3000Hz	dB	-12.5~-8.5
6.Adjacent ch.Rejection	dB	≥70
7.Image rejection	dB	≥70
8.Intermod rejection(3-Gen.Method)	dB	≥68
9.Spurious response rejection(CH16)80MHz to 1GHz	dB	≥70
10.Scan time. Per channel	ms	≤200
11.Speaker output		
12.StandBy Current	mA	≤65
13.Max Audio Power	mA	≤380
14.Charging current	mA	760±130
GENERAL STANDARD		
1. Floating&Flash		
2. Waterproof: IPX8		
3.Communication Range: About 5 nautical miles		
4. Individual/removable battery with charger cradle		
DIMENSION & WEIGHT		
Dimension (L/W/H)	mm	130×58×30
Weight	g	220