

Flexofold Limited Warranty:

1. Liability for defects:

1.1. Upon delivery the buyer shall immediately perform proper checks of the goods supplied before such goods are put to use and shall not later claim defects which the Buyer should have discovered during such a check.

1.2. The Seller shall not be liable for operating loss, loss of profit or other financial loss incurred by the Buyer or third party as a result of defects in the goods supplied.

1.3. The Seller shall, pursuant to the provisions of the Clauses below, by repair or replacement, remedy any defects in the goods resulting from faulty design, materials or workmanship.

1.4 The Seller's liability is limited to defects which appear within a period of 3 years from the date of delivery of the goods. If the goods are used more intensively than agreed or could be foreseen at the point of sale, this period shall be reduced proportionally.

1.5 The Buyer shall notify the Seller in writing of a defect without delay after the defect has become apparent, and in no case later than two weeks after the expiry of the period defined in Clause 1.4. The notice shall contain a description of how the defect manifests itself.

Notice of a defect shall be given immediately if there is reason to believe that the defect may cause damage.

If the Buyer fail to notify the Seller of a defect in writing within the time limit set, he shall forfeit his right to make any claim in respect to the defect.

1.6 On receipt of the written notice according to Clause 1.5, the Seller shall remedy the defect without undue delay and at his own cost. Remedy of the defect shall take place at the Buyer's premises unless the Seller finds it appropriate to have the defective part or the goods returned to him for repair or replacement at his own premises.

The Buyer shall assume the cost of transportation of goods to the Sellers premises. All other costs in connection with repair or replacement shall be at the Seller's risk and expense.

1.7 If the defects may be considered substantial, the Buyer may instead choose to terminate the purchase by written notice to the Seller.

1.8 The Seller is only liable for defects which appear under the conditions of operation provided for and under proper use of the goods. The liability does not cover defects which are caused by faulty maintenance or incorrect installation from the Buyers side. Finally the liability does not cover normal wear and tear or deterioration from corrosional and other attacks.

2. Liability for Damage to Property caused by the Goods (Product liability):

The Seller shall solely be liable for defects in accordance with mandatory provisions.

The Buyer shall indemnify and hold the Seller harmless to the extent that the Seller incurs liability towards any third party in respect of any damage for which the Seller is not liable towards the Buyer according to paragraph a. and b. below.

The Seller shall not be liable for loss or damage caused by the goods:

- To any (movable or immovable) property where the damage occurs while the goods are in the Buyer's possession
- To products manufactured by the Buyer or to products of which the Buyers products form a part or loss or damage to any property, where the damage is caused by these products because of properties in the goods.

The seller shall under no circumstances be liable for loss of production, loss of profit or any other consequential economic loss.

The above limitations in the Seller's liability shall not apply where the Seller has been guilty of gross negligence.

If a claim for loss or damage as described in this Clause is raised by a third party against either party, the latter shall forthwith notify the other party thereof.

The Seller and the Buyer shall be mutually obliged to let themselves be summoned to the court or arbitral tribunal which examines claims against either of them, where the claim is based on damage alleged to have been caused by the goods. The liability as between the Seller and the Buyer shall, however, always be settled by the arbitration in accordance with Clause 3.

3. Disputes. Applicable Law:

Each and every dispute between the parties shall not be brought before the court, but shall be finally settled by arbitration in accordance with the law on arbitration applicable in Denmark.

Flexofold ApS
info@flexofold.com
T: (+45) 7555 4346

Flexofold Deutschland
info@flexofold.com
T: (+49) 461 481 5610

Flexofold North America
info@flexofold.com
T: (+1) 781 797 0809



Installations and operating instructions for 2-blade Flexofold propeller on a Torqeedo Cruise 10.0 Fixed Pod. Owner must receive these instructions.

NOTE: Failure to follow these instructions will void warranty.

These instructions cover installation and operation of Flexofold Propellers unless they have been modified by Flexofold in which case a supplement will be provided.

COMPOSITE PROPELLER

Parts list:

1. Hub
2. Shaft (part of Torqeedo POD)
3. Spacer
4. Self locking shaft nut M16x1.5
5. Lock washer
6. Cover
7. Blade (2 ea.)
8. Pivot pin (2 ea.)
9. Anchor Bolts (2 ea. M8x60mm)
10. Anode (2 ea..)
11. Screw (2 ea. M5x30)

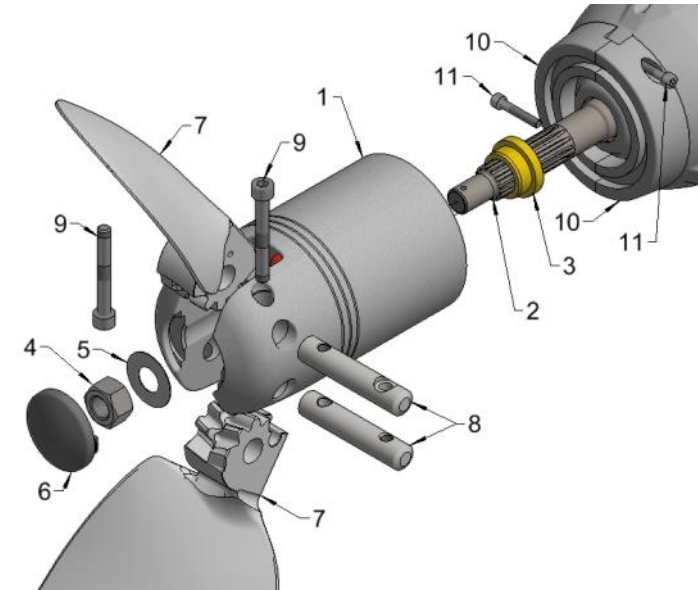

Thread locker:

There is an underwater proof thread locker pre-applied on all screws in the installation. These screws can be installed out of or under the water.

Normal fluidic thread locker is not designed to be applied or cure under water and attempts to apply it under water will ultimately fail. Nor can regular thread locker be applied to the thread in air and allowed to cure before the screw is mounted under water. There will be no adhesion.

If removing the propeller underwater for any reason, do not reuse the screws and nut when mounting again under the water. Please contact Flexofold for replacement screws that have the pre-applied thread locker.

When reusing the screws out of the water, make sure to apply a medium strength version of thread locker, for instance Loctite 243 (blue).

Never use a thread locker on the shaft nut (4). It will be difficult to dismount again.

Operating and handling instructions:

- Check that the propeller functions in both forward and reverse before each voyage.
- When sailing, propeller must be stopped for the blades to fold. Stop motor.
- Stop motor immediately if any strange sounds or vibrations are noticed coming from propeller.
- Do not operate propeller when close to people or animals.
- When handling assembled propeller, avoid being pinched by opening or closing blades.
- The only maintenance required is to keep propeller clean.
- No need to oil or grease, the parts are water lubricated as soon as in the water.

Installation of hub

1.1 Mount anodes (10) on Pod with screws (11).

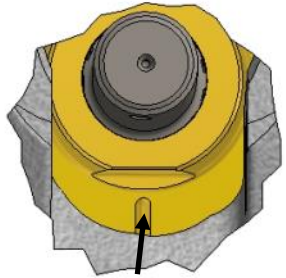

1.2 Localize mark and flat face on inner hub.

2.1 When tightening shaft nut use unmounted blade to keep shaft from turning.

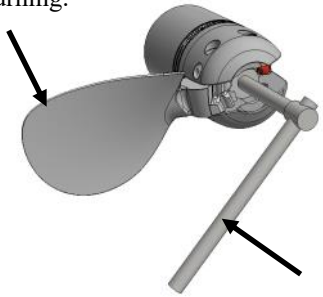

3 Again using a straight screw driver or similar: Bend lock washer up over the hexagon on the shaft nut locking screw (6). This along with the self locking nut will prevent nut from backing out.

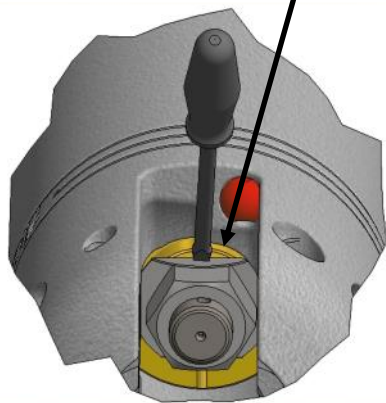

A plier might help bending the lock washer.



1.3 Check to see that the spacer (3) is installed like shown. Propeller will not function properly without the spacer; slide hub (1) gently over splines on shaft (2); Mount the lock washer (5) and screw on shaft nut (4) and tighten firmly. Shaft nut torque about 70 Nm (7 kpm, 50 ft-lb).

Don't use any thread locker on shaft nut (4).

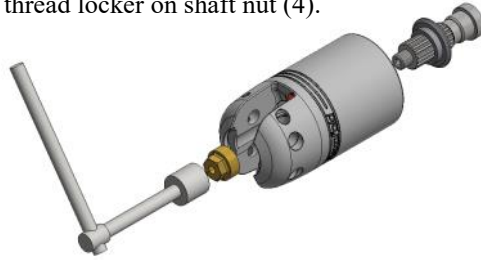

2.2 Using a screw driver or similar: Bend the lock washer down over flat face of inner hub.

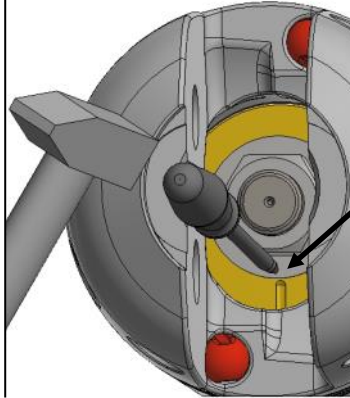

If removing propeller; straighten side of lock washer to allow removal of shaft nut locking screw.

Installation of blades

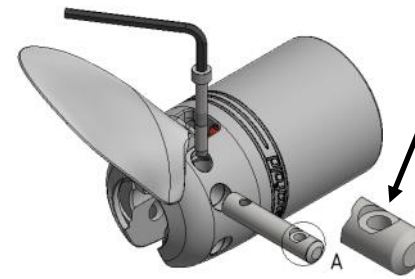

4 Align blade (7) in hub jaw and insert pivot pin (8) with the stepped hole in the shown position.

Move blade slightly to ease operation, and apply pressure on the pivot pin all the way in.

Mount an anchor bolt (9) partly in the bore; Align pivot pin and anchor bolt with bore. Do not push the anchor bolt all the way in yet; that will happen in next step.

5 Insert next blade (7), pivot pin (8) and anchor bolt (9). Engage thread as soon as both blades, pivot pins and anchor bolts are in place. Tighten light and check function. Final tightening will be done in step 6 with final adjustment in step 7.



6 Now tighten both anchor bolts. The torque must be around 5 Nm (0.5 kpm, 40 ft-lb.) The blades should now be too tight for the folding mechanism to work normal.

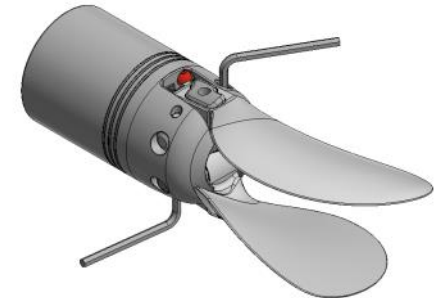

7 Release both anchor bolts approx. 1/8 turns counter clockwise (45 degrees). Check the function, i.e. work blades open and folded to ensure ease of operation. Release anchor bolts slightly more if the blades sticks, and please remember that both anchor bolts must be released equally.

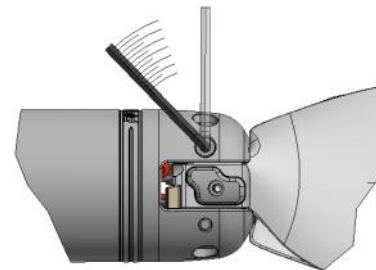

8 Place the cover (10) as shown and click it into place. Finally work blades open and folded to ensure ease of operation.

