

ISSUE	DATE / NAME	PH	MOD No.
A	09.05.06	PH	N/A
B	30.05.07	PH	10782

(B)

EXTENSION m.m	KI <sup>-</sup> No.	34 - 40 WINCH			44 - 48 WINCH			X	Y	Z
		R	S	T	R	S	T			
25	48034500	186,0 7 5/16"	129,0 5 1/16"	59,5 2 5/16"	216,0 8 1/2"	159,0 6 1/4"	89,5 3 1/2"	B0683 x5	WSK 5334-3 Ref.Mo.tl. HE.30.TF	NOT REQUIRED
30	48034501	191,0 7 1/2"	134,0 5 1/4"	64,5 2 9/16"	221,0 8 3/4"	164,0 6 1/2"	94,5 3 3/4"	B0684 x5	40000228 Ref.Mo.tl. HE.30.TF	NOT REQUIRED
50	48034502	211,0 8 5/16"	154,0 6 1/16"	84,5 3 5/16"	241,0 9 1/2"	184,0 7 1/4"	114,5 4 1/2"	B0841 x5	WSK 5475-2 Ref.Mo.tl. HE.30.TF	40004074 Re: Mo.tl. FV 520
70	48034503	231,0 9 1/16"	174,0 6 7/8"	104,5 4 1/8"	261,0 10 1/4"	204,0 8"	134,5 5 1/4"	B0804 x5	40001467 Ref.Mo.tl. HE.30.TF	40004335 Re: Mo.tl. FV 520
76	48034504	235,0 9 1/4"	179,0 7 1/16"	110,5 4 3/8"	265,0 10 3/8"	209,0 8 1/4"	140,5 5 1/2"	B0800 x5	40002015 Ref.Mo.tl. HE.30.TF	40002016 Ref.Mo.tl. FV 520

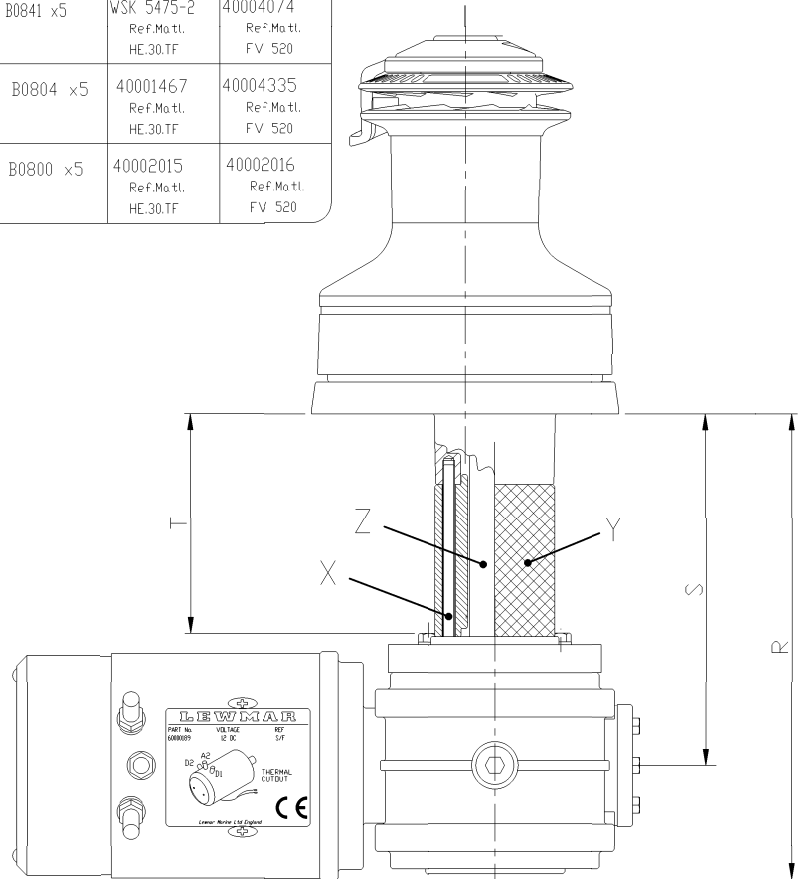

NOTE  
DRIVE SHAFT EXTENSION OTHER THAN THOSE LISTED BELOW  
CAN BE CONSIDERED & DR ARRANGED FROM THESE DESIGNS

CUSTOMER TO SUPPLY SUPPORT  
BRACKET FOR MOTOR/GEARBOX  
UNDER DECK (4 HOLES M8  
ON A 85 PCD)

PLAN VIEW FROM DECK TOP

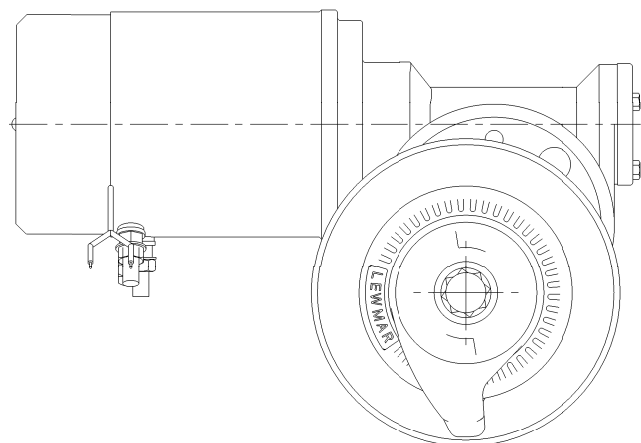

34-48 DRIVE EXTENSIONS

SCALE 1 : 1

ALL DIMS IN mm

DRN	P.H.	DRG. No 48034500
DATE	09.05.06	

**LEWMAR**