

# INSTALLATION INSTRUCTIONS

## AND OWNERS MANUAL

Part # IS-SH5094-1, Rev 0, 08/2014

[www.seastarsolutions.com](http://www.seastarsolutions.com)



Mechanical Steering for Inboard, Outboard and  
Sterndrive Powered Vessels

SAFE-T® DUAL QC ROTARY STEERING HELM SH5094-1

*big-t*  
*jbs*  
*nfb*  
*rack*  
*safe-t*  
*xtreme*

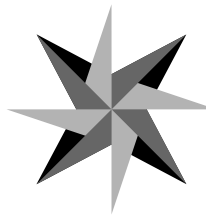

SEASTAR  
SOLUTIONS®

*Before you do it your way,  
please try it our way.*

# SAFE-T® DUAL QUICK CONNECT HELM

## SH5094-1

### NOTICE

*Installer: these instructions contain important safety information and must be forwarded to the boat owner.*

These instructions describe how to install a SSC62 steering cable into Safe-T® Dual Quick Connect Helms. Instructions for mounting the helm to the bezel are given in the bezel kit instructions.

In addition to this kit the following components are required for a complete system:

- Bezel Kit SB27484P (90°) or SB27483P (20°)
- SSC62xx Steering Cable (where xx is length in feet)
- Engine Connection Kit (refer to SeaStar Solutions catalog)
- Steering Wheel (refer to SeaStar Solutions catalog; Maximum wheel diameter 16", Maximum wheel dish 5")

### DANGER

**If steering cable is stiff in operation, it is unsafe to use and must be replaced immediately.**

### WARNING

**Before starting installation read these instructions and engine makers instructions thoroughly. Failure to follow either of these instructions or incorrect assembly can result in loss of control and cause property damage, injury, or death.**

### WARNING

**DO NOT substitute parts from other manufacturers, they may cause a safety hazard for which SeaStar Solutions cannot accept responsibility. Use only SeaStar Solutions steering cables with this helm.**

### WARNING

**To avoid excessive steering loads, and to get the best steering performance, the outboard motor or outdrive trim tabs and tilt position must be adjusted as instructed in the motor manufacturers operation manual. Failure to do so can effect the performance of the boat and its safe operation which may cause property damage, injury, or death.**

### WARNING

**DO NOT attach any electrical ground wires to the helm. This would result in an electrolytic reaction to the steering system that may result in system failure or greatly reduced service life.**

### WARNING

**Helms must not be disassembled for any reason. Failure to reassemble correctly may lead to total failure of the system, which could result in property damage, injury, or death.**

### NOTICE

*OUTBOARD APPLICATIONS: This system is only recommended as replacement for the original system as installed by the boat manufacturer. SeaStar Solutions always recommends NFB™ (or No Feed Back) helms for outboard applications. NFB™ helms lock out steering loads caused by propeller torque eliminating the driver fatigue normally experienced with a standard helm. Patented SeaStar Solutions NFB™ steering helms are a drop in replacement for Safe-T® systems.*

### NOTICE

*When replacing an existing steering system it is recommended that you stay with the style (rotary or rack) the boat manufacturer installed. Never change your steering from a dual cable to a single cable system, as this could cause an unsafe boating condition.*

## NOTICE

Helms and cable assemblies are supplied lubricated ready for installation, do not add any lubricant to either assembly. Use of other lubricants can cause damage to the steering cable, resulting in the cable seizing or premature wear. Keep the cable and drive assembly clean during installation. Dirt will damage the system and cause premature wear. Do not take the plastic sleeve off the end of the cable until you are ready to install it into the helm.

This notice does not include the engine output ram end of the cable.

## Preparation for Installation

Before the steering cable can be installed, the helm, bezel, and steering wheel must be fully installed as shown in the bezel kit instructions.

## Steering Cable Routing

The helm assembly can be mounted for either port or starboard cable routing. Steering cables, if possible, should be routed to the starboard side of the boat in order to balance engine torque.

When routing the steering cable(s), select a path with the minimum number of bends, making the bends as large as possible. **DO NOT MAKE BENDS OF LESS THAN 8" RADIUS.** Sharp or frequent bends will result in hard steering and premature cable wear. When it is necessary to pass through a bulkhead, a 1-1/2" diameter hole is required. Cable should be loosely clamped or tied for support at regular intervals.

## CAUTION

**Cables must not be bundled together with electrical wiring.**

**Cables must not rest on sharp edges which can cause chafing.**

## Helm Installation

Refer to Bezel Kit instructions.

## Steering Cable Installation

Before the steering cable is installed the steering wheel should be positioned as shown in figure 1, so that it is in the correct orientation when the installation is completed.

**STEP 1.** Remove both pins from the helm's cable entry spigots.. **DO NOT REMOVE THE TAG FROM THE PIN.** The back of the helm is marked for typical (starboard cable routing) installation. If port cable routing is desired, use opposite side spigot (see Figure 2).

**STEP 2.** Remove protective sleeve from cable end, making sure that dirt does not get onto the lubricated cable end. Feed cable end into **LOWER** (starboard cable routing) helm entry spigot until it contacts the internal gear, then turn steering wheel to draw cable fully into the helm, (see Figure 3). Continue turning the wheel after the cable end enters the helm spigot. Some pressure will be felt and there will be an audible click as the locking mechanism engages. Continue turning past that point until the wheel cannot be turned any further. Turn steering wheel fully in the other direction until it cannot be turned any further, check that cable end fitting is retained inside the entry spigot.

**STEP 3.** Replace pin as shown in Figure 4, making sure that it is fully seated. If pin cannot be inserted, the cable is not fully seated in the helm. Push on cable to ensure that it is fully home. **DO NOT REMOVE TAG FROM PIN.**

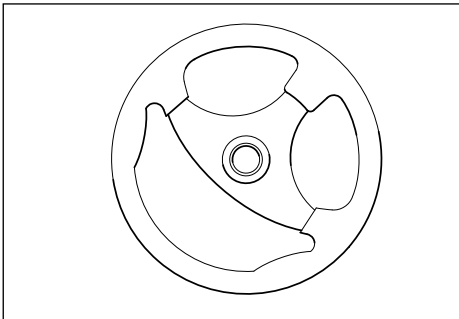

Figure 1A: Starboard cable routing.

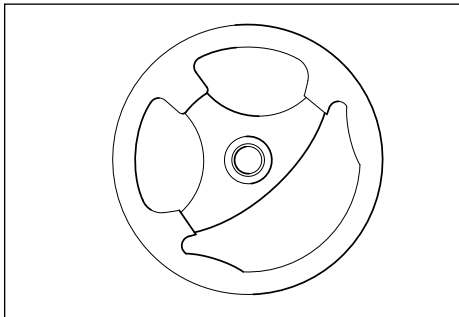

Figure 1B: Port cable routing.

**STEP 4.** Turn the steering wheel fully to both extremes of rotation and check that the cable fitting is retained in the entry spigot.

**STEP 5.** Feed spent travel tube (item 2, Figure 3) over the exposed cable end until you hear it click into place in the helm spigot. Then insert pin as shown in Figure 4 until it is fully seated.

**STEP 6.** Rotate the steering wheel several times from stop to stop, and watch the movement of the steering cable output ram. On starboard mounted helms turning the wheel clockwise should cause the ram to extend. On port mounted helms turning the wheel clockwise should cause the ram to retract.

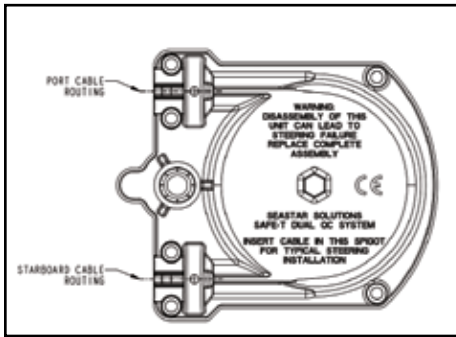

Figure 2.

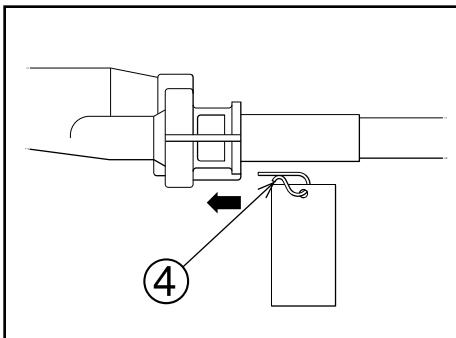

Figure 4.

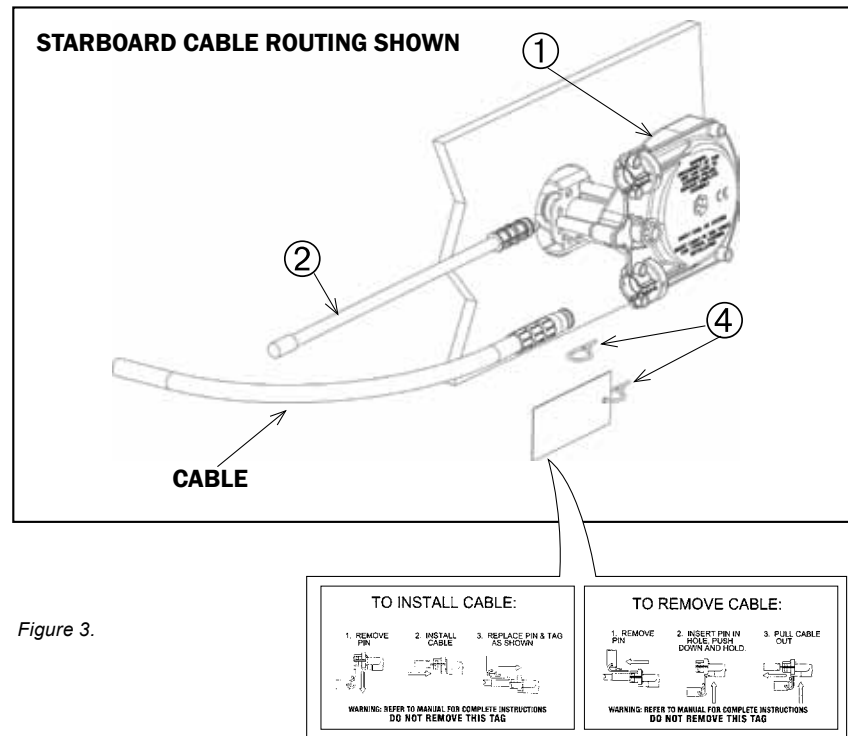

Figure 3.

## Connection to Engine

For engine-mounted steering systems, slide the output ram through the engine support tube. Thread the cable coupler nut fully onto the support tube.

For a boat-mounted steering system, attach the cable to the boat and engine in accordance with the instructions furnished with the connection kit.

### ⚠ CAUTION

**The output ram end of the steering cable should be lubricated with a good Waterproof Marine Grease before being inserted into the support tube.**

### ⚠ CAUTION

**Ensure that the cable output end is not bent when installing into the engine. If necessary remove the engine from the boat.**

### NOTICE

The coupler nut has a locking ring in the threads. Make sure the nut is drawn up fully and its internal plastic locking ring is engaged. If you do not tighten this nut fully there will be excessive play in the steering system. Connect the cable output ram to the engine tiller arm as shown in the instructions packed with the connection kit.

## Helm Parts List

ITEM	QTY	DESCRIPTION
1	1	Helm
2	1	Spent Travel Tube
*3	3	1/4 x 3/4" Long Hex Bolt
4	2	Pin (1 with white tag, 1 without tag)

\* Pictured in bezel kit instructions.

## Operation & Maintenance Notes

### CAUTION

It is possible to over trim the engine and increase the steering torque to the point that the steering wheel cannot be turned. This may give the impression that the steering is "locked". This condition can occur more when jack plates are used to raise the engine on the transom, and can only be overcome by reducing the boat speed or engine trim out position. Until you are completely familiar with the boat and the effects of power trim, make all adjustments of trim with extreme caution.

1. After a few hours of operation and at frequent intervals thereafter, check all fasteners and the complete steering system for security and integrity.

### DANGER

**Loosening or loss of one or more fasteners may cause failure of the steering system, resulting in loss of steering control and could cause property damage, injury, or death.**

2. Keep all moving parts free from build-up of salt and other foreign material. This will affect their operation and create steering problems. Periodically remove the cable, clean support tube and telescopic end of cable thoroughly and lubricate with a **waterproof marine grease**.

3. Periodically inspect for corrosion. Any parts affected by corrosion must be replaced. When replacing hardware, self-locking hardware as originally supplied must be used.

4. Periodically inspect steering cable for cracks or other damage. If any is found the cable must be replaced.

### DANGER

**If steering cable is stiff in operation, it is unsafe to use and must be replaced immediately.**

### DANGER

**DO NOT cover cracks with tape or other sealants, this will create a hazard in which the cable can fail suddenly without warning, resulting in property damage, injury, or death.**

### NOTICE

*Boat builder and boat dealer, please supply these Installation Instructions and Owner's Manual with the delivery of boat. Boat owner keep these instructions with your boat for future reference. Boat owner consult with your boat builder, boat dealer, or SeaStar Solutions if you have any questions regarding these instructions.*



**SEASTAR  
SOLUTIONS®**

640 North Lewis Road  
Limerick, PA 19468 USA  
610-495-7011  
[www.seastarsolutions.com](http://www.seastarsolutions.com)

**ISO 8848**



© 2014 MARINE ACQUISITION (US) INC.

PART # IS-SH5094-1 08-2014 Rev. 0