

SEASTAR™

FRONT MOUNT CYLINDER HIGH STRENGTH TILLER BOLT KIT Part # HA5822

⚠ WARNING

The nut/bolt in this kit are to be used with ALL 300HP+ outboard engines as well as ALL Mercury XS engines. Failure to use this high strength bolt may result in steering failure leading to property damage and personal injury and/or death.

Installation Instructions

1. Confirm that any shipping nuts, plugs and/or caps that are installed in the outboard engine tiller arm are "removed".
2. Referring to the Installation Manual included with your steering cylinder, lightly grease the tiller bolt (item 1) and partially thread into the hole noted in the Installation Manual to confirm a proper fit.
3. Remove bolt.
4. If required, lightly re-grease tiller bolt. Mount steering cylinder as it is shown in the steering cylinder Owner's Manual (Book 1.1, shipped with cylinder). Thread tiller bolt (item 1) completely into the engine steering arm. While holding the head of the bolt with a wrench, tighten and torque the tiller nut (item 2) to 259 in-lb (21 ft-lb).
5. Continue with complete cylinder installation as outlined in your owner's manual.

⚠ WARNING

It is highly recommended that the tiller bolt head is held in place with a wrench while the tiller nut is torque to the proper specification, failure to do so may result in loss of steering control causing property damage, personal injury and/or death.

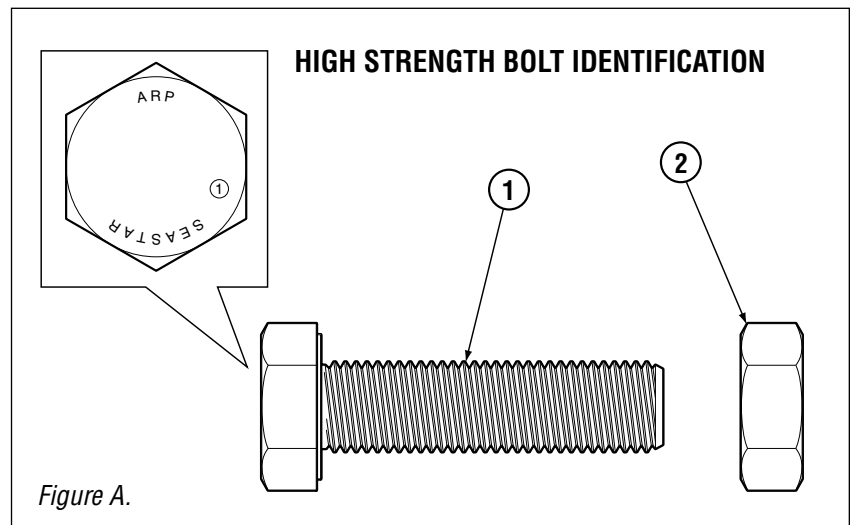

ITEM	PART#	QTY	DESCRIPTION
1	113225	1	High Strength HHCS 3/8UNJFX1.35 HSS BOLT
2	113529	1	NUT 3/8NF NYLOC THN SS