

MEMBER
ABYC
Setting Standards for Safer Boating

INSTALLATION INSTRUCTIONS

AND OWNERS MANUAL

Part # 055001-503, Rev 0, 12/2013

www.seastarsolutions.com

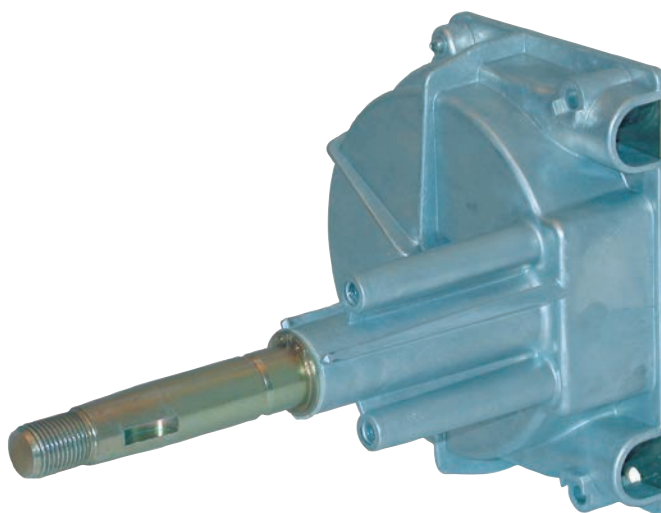

Command 290 Steering System
20° and 90° Bezel Kits

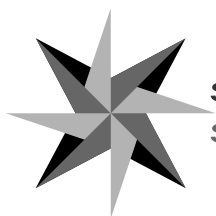

SEASTAR
SOLUTIONS®

*Before you do it your way,
please try it our way.*

big-t
jbs
nfb
rack
safe-t
xtreme

MANUFACTURED BY
MARINE ACQUISITION INCORPORATED
DBA SEASTAR SOLUTIONS
U.S.A.

COMMAND 290 STEERING SYSTEM

292748 (90° Bezel Kit)

292747 (20° Bezel Kit)

NOTICE

Installer: these instructions contain important safety information and must be forwarded to the boat owner.

The SeaStar Solutions Command 290 Steering System is designed to mount the wheel parallel to the dash, or 20° from parallel by using one of the Bezel Kits—90 degree or 20 degree.

Throughout the text, part names are followed by a number in parentheses. Refer to Parts Breakdown on the last page for visual identification

NOTICE

OUTBOARD APPLICATIONS: This system is only recommended as replacement for the original system as installed by the boat manufacturer. SeaStar Solutions always recommends NFB™ (or No Feed Back) helms for outboard applications. NFB™ helms lock out steering loads caused by propeller torque eliminating the driver fatigue normally experienced with a standard helm. Patented SeaStar Solutions NFB™ steering helms are a drop in replacement for Command 290 systems.

NOTICE

When replacing an existing steering system it is recommended that you stay with the style (rotary or rack) the boat manufacturer installed. Never change your steering from a dual cable to a single cable system, as this could cause an unsafe boating condition.

⚠ WARNING

Before starting installation read these instructions and engine makers instructions thoroughly. Failure to follow either of these instructions or incorrect assembly can result in loss of control and cause property damage, injury, or death.

⚠ WARNING

DO NOT substitute parts from other manufacturers, they may cause a safety hazard for which SeaStar Solutions cannot accept responsibility. Use only SeaStar Solutions steering cables with this helm.

⚠ WARNING

To avoid excessive steering loads, and to get the best steering performance, the outboard motor or outdrive trim tabs and tilt position must be adjusted as instructed in the motor manufacturers operation manual. Failure to do so can effect the performance of the boat and its safe operation which may cause property damage, injury, or death.

⚠ WARNING

DO NOT attach any electrical ground wires to the helm. This would result in an electrolytic reaction to the steering system that may result in system failure or greatly reduced service life.

NOTICE

Helms and cable assemblies are supplied lubricated ready for installation, do not add any lubricant to either assembly. Use of other lubricants can cause damage to the steering cable, resulting in the cable seizing or premature wear. Keep the cable and drive assembly clean during installation. Dirt will damage the system and cause premature wear. Do not take the plastic sleeve off the end of the cable until you are ready to install it into the helm.

This notice does not include the engine output ram end of the cable.

⚠ WARNING

Helms must not be disassembled for any reason. Failure to reassemble correctly may lead to total failure of the system, which could result in property damage, injury, or death.

Install Helm Assembly

STEP 1. When installing the steering system, as with all Marine equipment, apply a light coating of good quality marine grease to all threads and mating surfaces for maximum corrosion protection.

STEP 2. Refer to Figures 1, 2, and 3 for mounting dimensions.

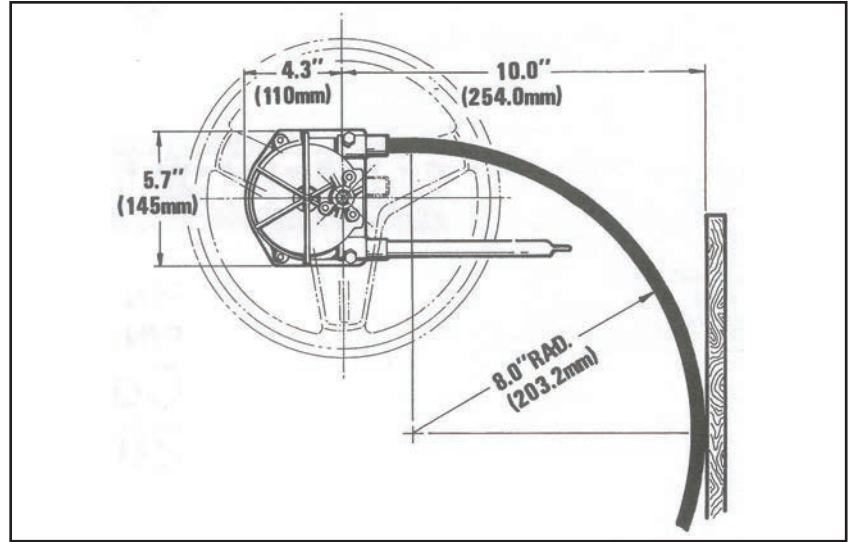

Figure 1.

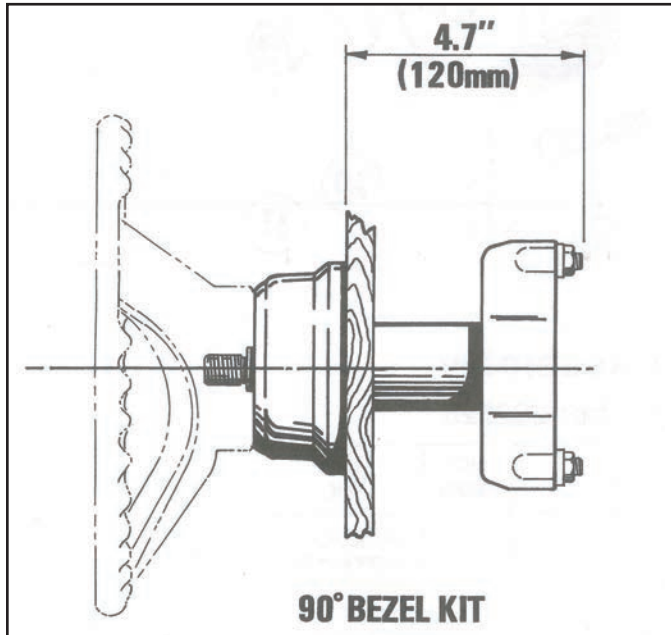

Figure 2.

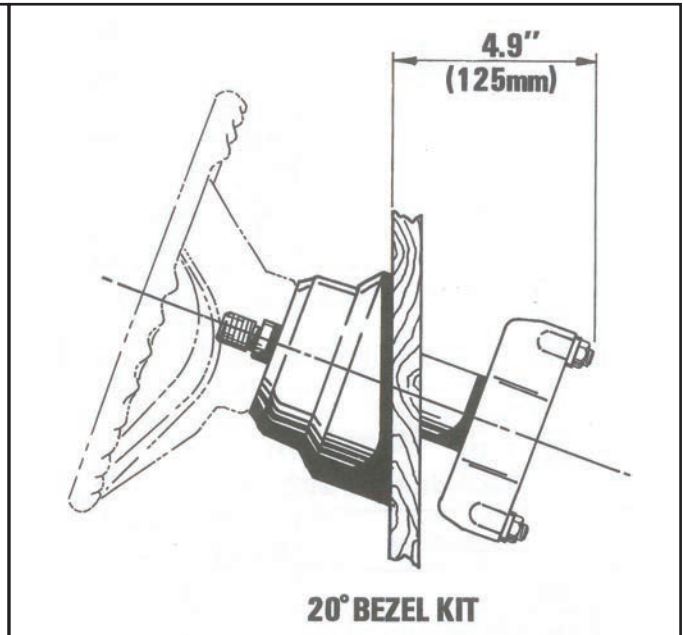

Figure 3.

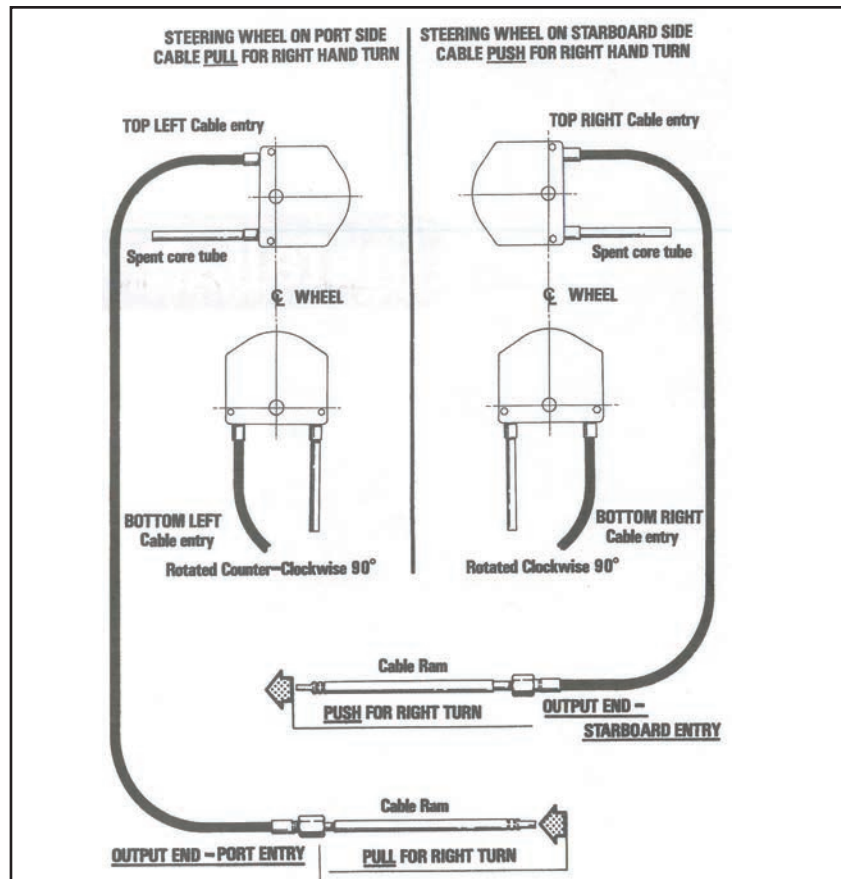

Figure 4.

STEP 3. Locate the full-size mounting template at the desired location with the top hole at the top position and tape in place. Drill the three each $11/32$ " diameter holes perpendicular to the face of the dash. Then cut or drill the 3" diameter center hole. Locate the Mounting Bracket (#1 or #8) on the dash and secure with the Bolts (#2), Washers (#3) and Lock Nuts (#4) supplied. Torque the Lock Nuts to 50 in. lbs.

STEP 4. The Helm Assembly can be rotated on the Mounting Bracket to accommodate Cable entry. The best position for the Drive Unit is where the Cable can be installed with the minimum amount of bending. Figure 4 shows the Cable End positions for either PUSH or PULL for right turn operation. The Drive Assembly is adjustable in 45 degree increments from the top right or top left cable entry positions.

STEP 5. Insert the Helm through the cutout in the dash. Attach the Helm to the Mounting Bracket (#1 or #8) and secure with Bolts (#5) provided. Torque the Bolts to 25-30 in. lbs.

STEP 6. For 20° Bezel Kit—Place Trim Bezel (#9) over the Shaft with the word "SeaStar Solutions" pointing upwards, and secure with screws (#16).

STEP 7. For 90° Bezel Kit—Place Trim Bezel (#7) over the Shaft with the word "SeaStar Solutions" pointing upwards, and snap in place over the three lugs on the Mounting Bracket (#1).

STEP 8. Place the Key (#6) into the slot on the Steering Shaft as shown in the Parts Breakdown. Align the Key (#6) with the keyway in the steering wheel and slide the steering wheel onto the Shaft.

STEP 9. Install the Washer (#10) and the Nut (#11) and tighten to 25-30 in. lbs.

Parts Breakdown

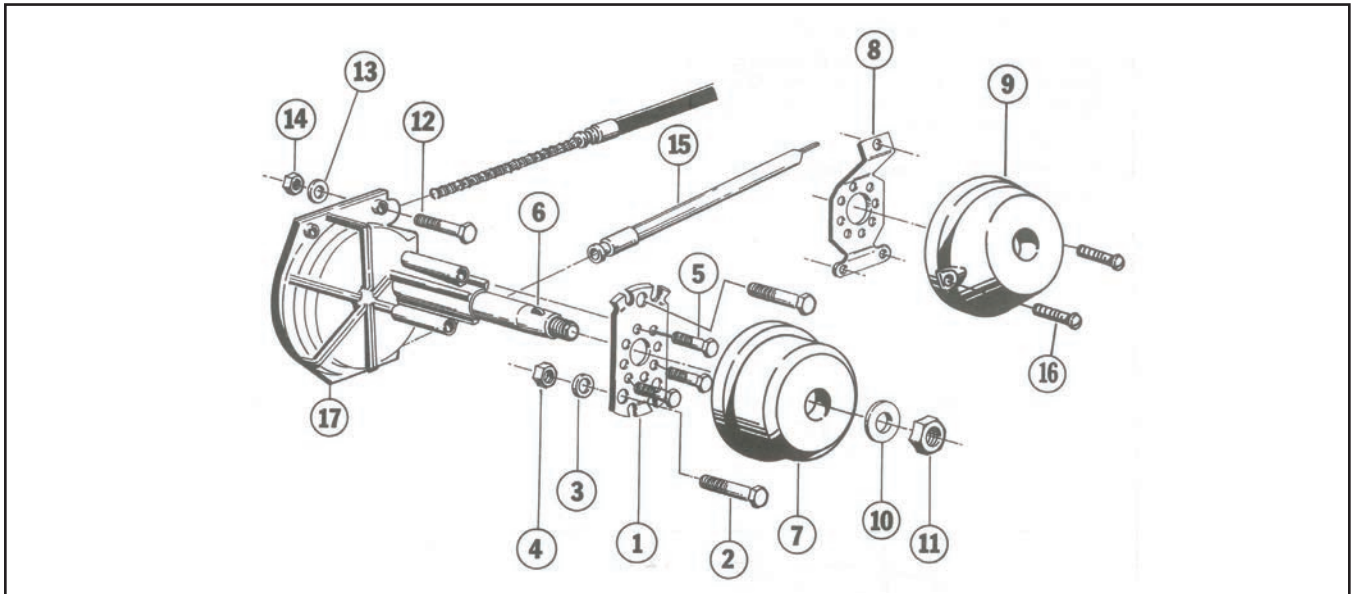

Helm Assembly Part Number D0290

ITEM	DESCRIPTION	NO. REQ'D	PART NUMBER
6	Key	1	052600-047
10	Washer, SST	1	050800-124
11	Elastic Stop Nut 5/8-18	1	050908-416
12	Bolt, 1/4-20 x 1-1/2	2	050406-889
13	Washer, 1/4 SAE	2	050800-068
14	Elastic Stop Nut 1/4-20	2	050908-056
15	Spent Core Tube	1	301098
17	Helm-Drive Assembly	1	309301

90° Bezel Kit Part Number 292748

ITEM	DESCRIPTION	NO. REQ'D	PART NUMBER
1	Bracket	1	292509
2	Screw 5/16-18 x 1-1/2	3	050407-282
3	Washer, 5/16 SAE	3	050802-077
4	Elastic Stop Nut 5/16-18	3	050908-075
5	Screw 1/2-20 x 5/8	3	050414-024
7	Trim Bezel	1	292512

20° Bezel Kit Part Number 292747

ITEM	DESCRIPTION	NO. REQ'D	PART NUMBER
8	Bracket	1	305234
2	Screw 5/16-18 x 1-1/2	3	050407-282
3	Washer, 5/16 SAE	3	050802-077
4	Elastic Stop Nut 5/16-18	3	050908-075
5	Screw 1/2-20 x 5/8	3	050414-024
9	Trim Bezel	1	293017
16	Screw, #10 Phillips	2	050589-154

Operation & Maintenance Notes

⚠ CAUTION

It is possible to over trim the engine and increase the steering torque to the point that the steering wheel cannot be turned, even though the torque is not felt at the wheel. This may give the impression that the steering is “locked”. This condition can occur more when jack plates are used to raise the engine on the transom, and can only be overcome by reducing the boat speed or engine trim out position. Until you are completely familiar with the boat and the effects of power trim, make all adjustments of trim with extreme caution.

1. After a few hours of operation and at frequent intervals thereafter, check all fasteners and the complete steering system for security and integrity.

⚠ DANGER

Loosening or loss of one or more fasteners may cause failure of the steering system, resulting in loss of steering control and could cause property damage, injury, or death.

2. Keep all moving parts free from build-up of salt and other foreign material. This will affect their operation and create steering problems. Periodically remove the cable, clean support tube and telescopic end of cable thoroughly and lubricate with a **waterproof marine grease**.

3. Periodically inspect for corrosion. Any parts affected by corrosion must be replaced. When replacing hardware, self-locking hardware as originally supplied must be used.

4. Periodically inspect steering cable for cracks or other damage. If any is found the cable must be replaced.

5. If cable is stiff in operation, it is unsafe to use and must be replaced immediately.

⚠ DANGER

DO NOT cover cracks with tape or other sealants, this will create a hazard in which the cable can fail suddenly without warning, resulting in property damage, injury, or death.

NOTICE

Boat builder and boat dealer, please supply these Installation Instructions and Owner's Manual with the delivery of boat. Boat owner keep these instructions with your boat for future reference. Boat owner consult with your boat builder, boat dealer, or SeaStar Solutions if you have any questions regarding these instructions.



SEASTAR
SOLUTIONS®

640 North Lewis Road
Limerick, PA 19468 USA
610-495-7011
www.seastarsolutions.com

ISO 8848



© 1998 MARINE ACQUISITION (US) INC.

PART # 055001-503 12-2013 Rev. 0