

MEMBER
ABYC
Setting Standards for Safer Boating®

INSTALLATION INSTRUCTIONS AND OWNERS MANUAL

Part # IS-SH91610/30, Rev 4, 07/2013

www.seastarsolutions.com

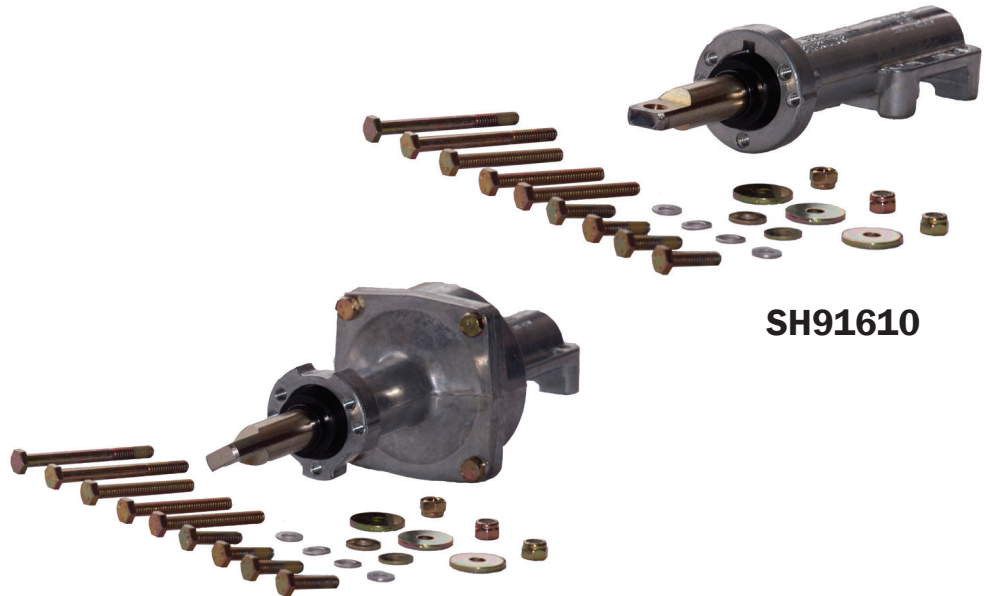

SH91610

SH91630

rack

Mechanical Tilt Steering for Inboard,
Outboard, and Sterndrive Powered Vessels

Back Mount Rack Helm SH91610/SH91630
For Performance Tilt Steering Systems

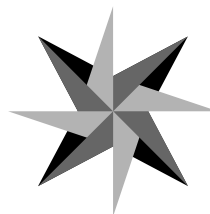

SEASTAR
SOLUTIONS®

big-t
jbs
nfb
rack
safe-t
xtreme

MANUFACTURED BY
MARINE ACQUISITION INCORPORATED
DBA SEASTAR SOLUTIONS
U.S.A.

*Before you do it your way,
please try it our way.*

BACK MOUNT RACK PERFORMANCE TILT STD. AND NFB™ HELMS

SH91610, SH91630

NOTICE

Installer: these instructions contain important safety information and must be forwarded to the boat owner.

These instructions describe how to install Standard and No Feedback versions of the *BACK MOUNT RACK HELM* for *PERFORMANCE TILT* steering systems. The No Feedback version contains a clutch mechanism to prevent the engine torque from being felt at the steering wheel. This reduces driver fatigue by eliminating constant fighting of the wheel. *It does not eliminate the engine torque.* This can only be reduced by proper trim and tilt setting by trial and error when running the boat.

In addition to this kit the following components are required for a complete *PERFORMANCE TILT* system:

- Sport or Sport Plus TILT MECHANISM
- SSC134xx CABLE (where xx is length in feet) For single cable system.
- SSC135xx CABLE (where xx is length in feet) For dual cable system.
- Engine Connection Kit (refer to SeaStar Solutions catalog)
- Steering Wheel (refer to SeaStar Solutions catalog) Maximum wheel diameter 16", maximum wheel dish 5".

DANGER

If steering cable is stiff in operation, it is unsafe to use and must be replaced immediately.

WARNING

Before starting installation read these instructions and engine makers instructions thoroughly. Failure to follow either of these instructions or incorrect assembly can result in loss of control and cause property damage, injury, or death.

WARNING

DO NOT substitute parts from other manufacturers, they may cause a safety hazard for which SeaStar Solutions cannot accept responsibility. Use only SeaStar Solutions steering cables with this helm.

WARNING

To avoid excessive steering loads, and to get the best steering performance, the outboard motor or outdrive trim tabs and tilt position must be adjusted as instructed in the motor manufacturers operation manual. Failure to do so can effect the performance of the boat and its safe operation which may cause property damage, injury, or death.

WARNING

DO NOT attach any electrical ground wires to the helm. This would result in an electrolytic reaction to the steering system that may result in system failure or greatly reduced service life.

WARNING

Helms must not be disassembled for any reason. Failure to reassemble correctly may lead to total failure of the system, which could result in property damage, injury, or death.

NOTICE

OUTBOARD APPLICATIONS: This system is only recommended as replacement for the original system as installed by the boat manufacturer. SeaStar Solutions always recommends NFB™ (or No Feedback) helms for outboard applications. NFB™ helms lock out steering loads caused by propeller torque eliminating the driver fatigue normally experienced with a standard helm. Patented SeaStar Solutions NFB™ steering helms are a drop in replacement for a standard version of the back mount rack helm.

NOTICE

NFB™ helms are not recommended for power assisted applications.

NOTICE

When replacing an existing steering system it is recommended that you stay with the style (rotary or rack) the boat manufacturer installed. Never change your steering from a dual cable to a single cable system, as this could cause an unsafe boating condition.

NOTICE

Helms and cable assemblies are supplied lubricated ready for installation, do not add any lubricant to either assembly. Use of other lubricants can cause damage to the steering cable, resulting in the cable seizing or premature wear. Keep the cable and drive assembly clean during installation. Dirt will damage the system and cause premature wear. This notice does not include the engine output ram end of the cable.

Preparation for Installation

If possible the steering cable should be routed to the starboard side of the boat in order to balance engine torque.

When routing the cable select a path with the minimum number of bends, making the bends as large as possible. **DO NOT MAKE BENDS LESS THAN 8" RADIUS.** Sharp or frequent bends will result in hard steering and premature cable wear. When necessary to pass through a bulkhead, a 1-1/2" diameter hole is required. The cable should be loosely clamped or tied for support at regular intervals.

STEP 1. Locate the position for the Helm Assembly on the dashboard.

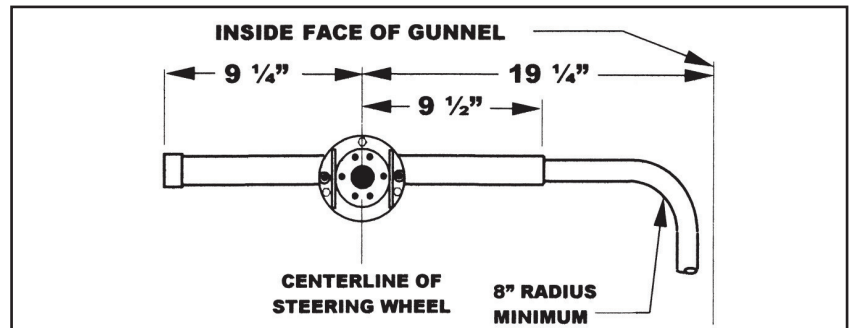

Figure 1.

CAUTION

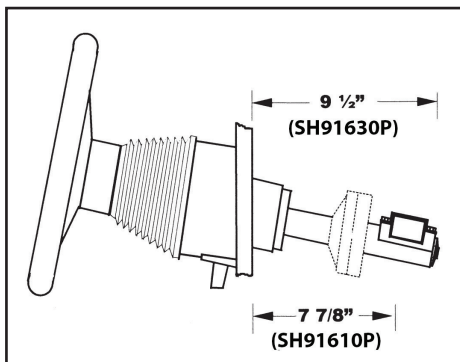

Figure 2.

Ensure that the clearances shown on Figures 1 and 2 are maintained. Ensure that the steering wheel does not interfere with other dashboard equipment such as engine controls and instruments.

STEP 2. Position the template (Figure 4) on the console or dashboard at the location previously marked, and drill three holes 5/16" diameter and one hole 2-7/8" diameter.

Helm Mounting Bracket installation

Secure the helm mounting plate (item 2) in position using three each of the 2-1/8" long hex bolts (item 3), large OD flat washers (item 4), and locknuts (item 5). Be sure the washers are on the inside of the dash as shown (see Figure 3). Tighten securely.

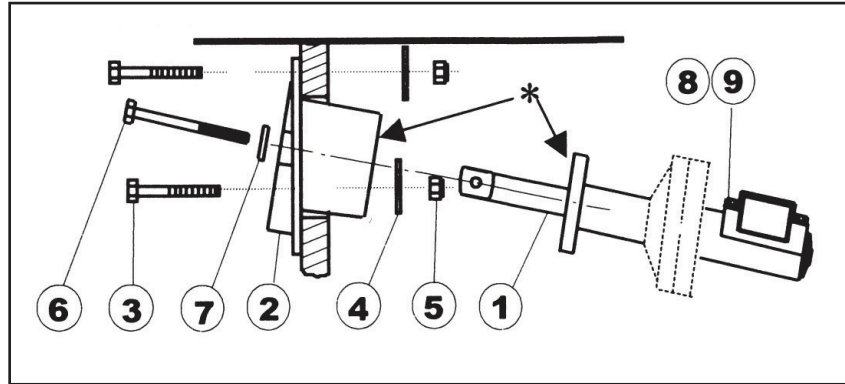

Figure 3.

Parts List

ITEM	DESCRIPTION	QUANTITY
1	Helm (SH91610P or SH91630P)	1
2*	Helm Mounting Plate	1
3*	1/4 x 2-1/8 Bolt	3
4*	Large OD 1/4 Flat Washer	3
5*	1/4 Locknut	3
6	1/4 x 2-1/2 Bolt w/ Lock Patch	2
7	Small OD 1/4 flat Washer	2
8	1/4" x 1" Long Lock Patch Bolt	4
9	Flat Washer, 1/2" OD	4

Note: Items 8-9 installed following instructions packed with the cable.

* Supplied with tilt mechanism

Cable-to-Helm Installation

Install the cable and drive (rack) assembly to the helm following the instructions provided with the cable and drive assembly (ref. IS-SC 134/135)

Cable & Helm Assembly-to-Helm Mounting Bracket Installation

Insert the helm shaft through the hole in the mounting bracket, orienting the helm so the rack and cable assembly are on top (see Figure 3). Secure in place using two 2-1/2" long locking patch hex bolts (item 6) and flat washers (item 7). Tighten bolts (75-125 inch-pounds).

NOTICE

*When tightening, draw mating surfaces * flush first before applying final torque. See Figure 3.*

NOTICE

When testing your steering, if it turns opposite of the desired direction, remove the rack from the helm and turn the helm 180 degrees. Remount the helm and rack assembly to the helm mounting plate as described above.

At this time refer to the instructions packed with the tilt mechanism hardware kit and install the tilt mechanism and the steering wheel.

Operation & Maintenance Notes

CAUTION

It is possible to over trim the engine and increase the steering torque to the point that the steering wheel cannot be turned, even though the torque is not felt at the wheel. This may give the impression that the steering is “locked”. This condition can occur more when jack plates are used to raise the engine on the transom, and can only be overcome by reducing the boat speed or engine trim out position. Until you are completely familiar with the boat and the effects of power trim, make all adjustments of trim with extreme caution.

1. After a few hours of operation and at frequent intervals thereafter, check all fasteners and the complete steering system for security and integrity.

DANGER

Loosening or loss of one or more fasteners may cause failure of the steering system, resulting in loss of steering control and could cause property damage, injury, or death.

2. Keep all moving parts free from build-up of salt and other foreign material. This will affect their operation and create steering problems. Periodically remove the cable, clean support tube and telescopic end of cable thoroughly and lubricate with a **waterproof marine grease**.

3. Periodically inspect for corrosion. Any parts affected by corrosion must be replaced. When replacing hardware, self-locking hardware as originally supplied must be used.

4. Periodically inspect steering cable for cracks or other damage. If any is found the cable must be replaced.

DANGER

If steering cable is stiff in operation, it is unsafe to use and must be replaced immediately.

DANGER

DO NOT cover cracks with tape or other sealants, this will create a hazard in which the cable can fail suddenly without warning, resulting in property damage, injury, or death.

NOTICE

Boat builder and boat dealer, please supply these Installation Instructions and Owner's Manual with the delivery of boat. Boat owner keep these instructions with your boat for future reference. Boat owner consult with your boat builder, boat dealer, or SeaStar Solutions if you have any questions regarding these instructions.

Mounting Template

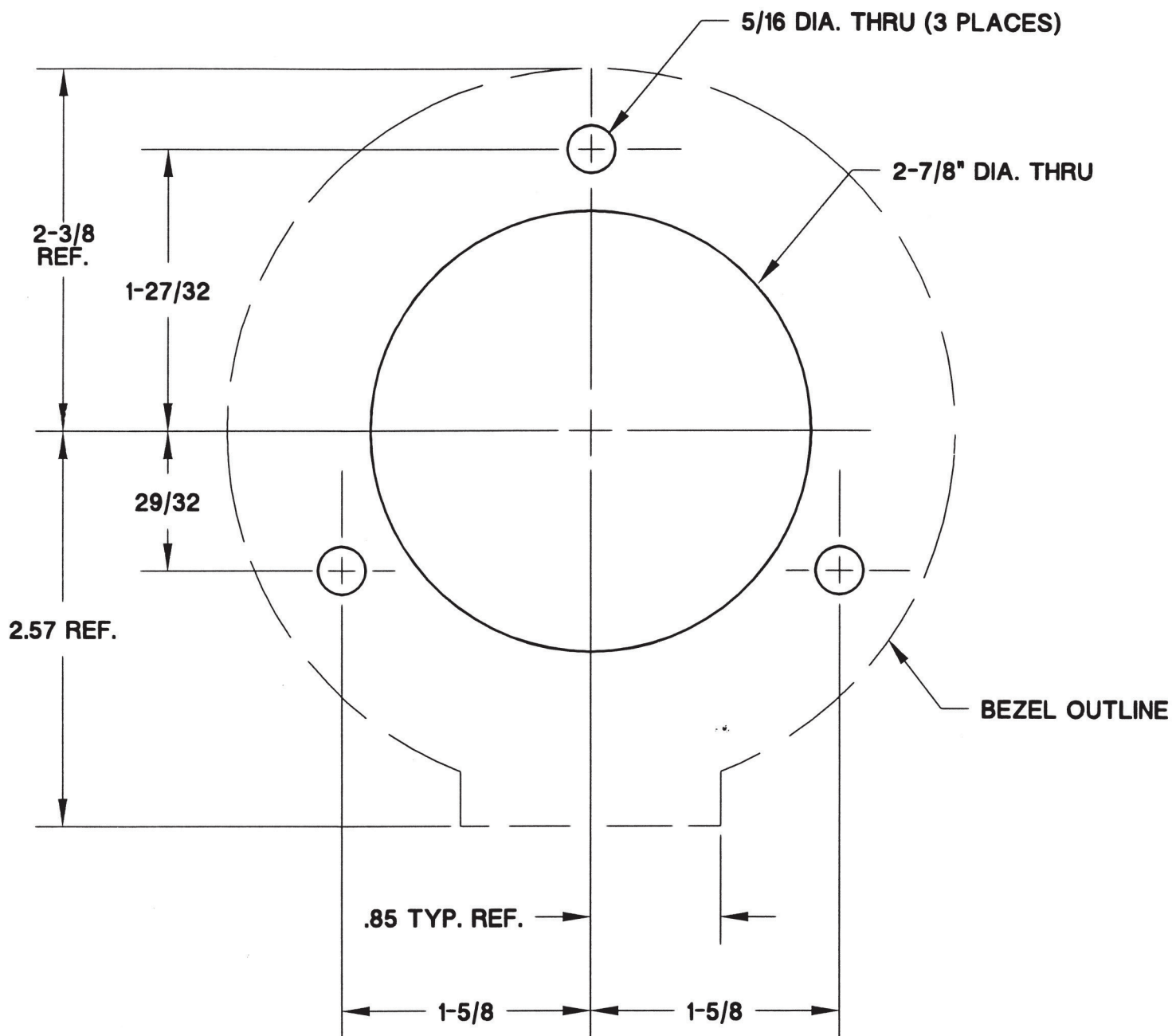

Figure 4.

NOTICE

If you must photocopy this mounting template for use, check ALL measurements using a measuring device prior to using as a template.



**SEASTAR
SOLUTIONS®**

640 North Lewis Road
Limerick, PA 19468 USA
610-495-7011
www.seastarsolutions.com

ISO 8848



© 1998 MARINE ACQUISITION (US) INC.

PART # IS-SH91610/30 07-2013 Rev. 4