

All Chain Wiring for Multiple AA 570 | 710 | 730 Products

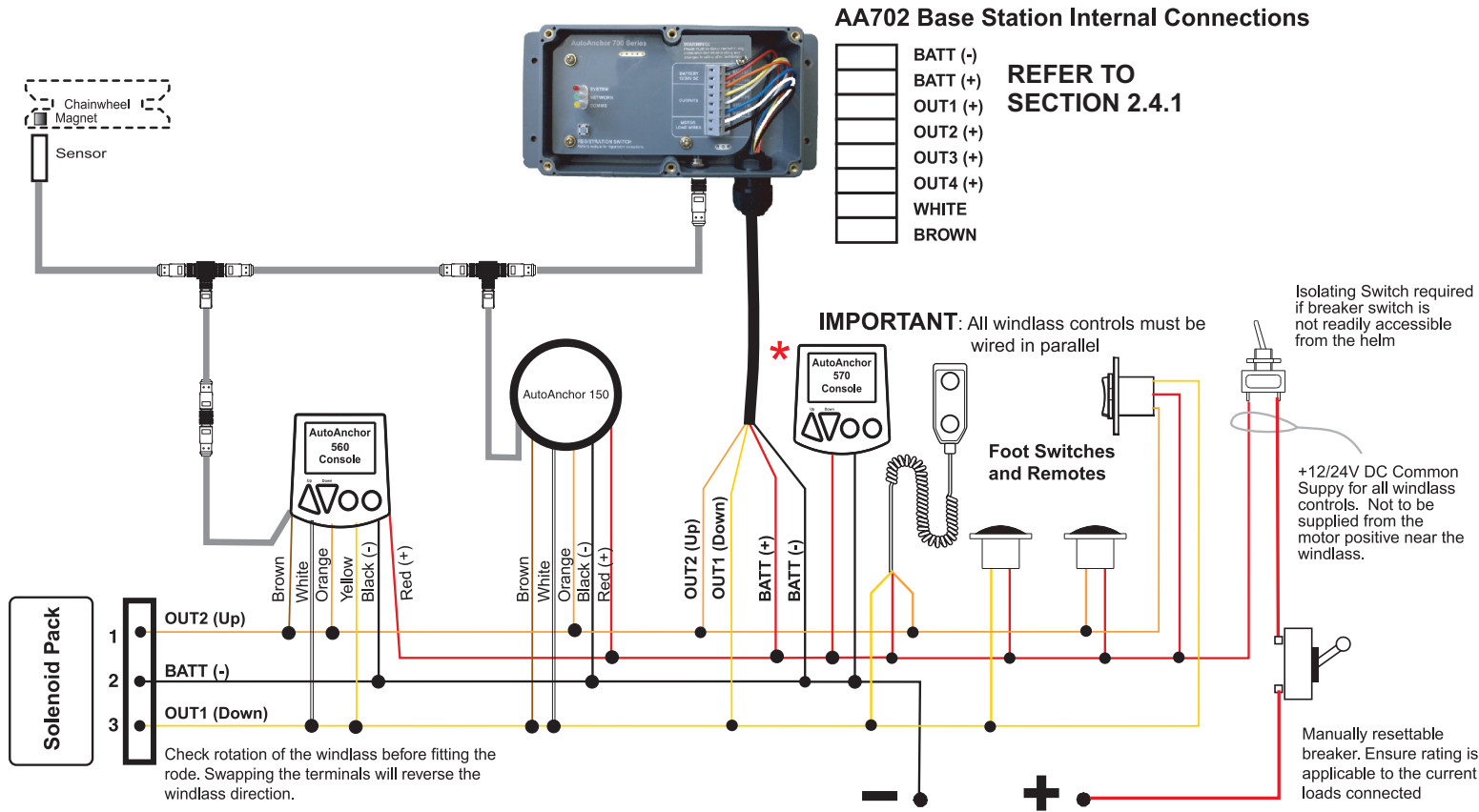

The * AA570 can also be connected directly into any 12v or 24v protected power supply

ROPE AND CHAIN WIRING FOR MULTIPLE AA 570, 710, 730 PRODUCTS

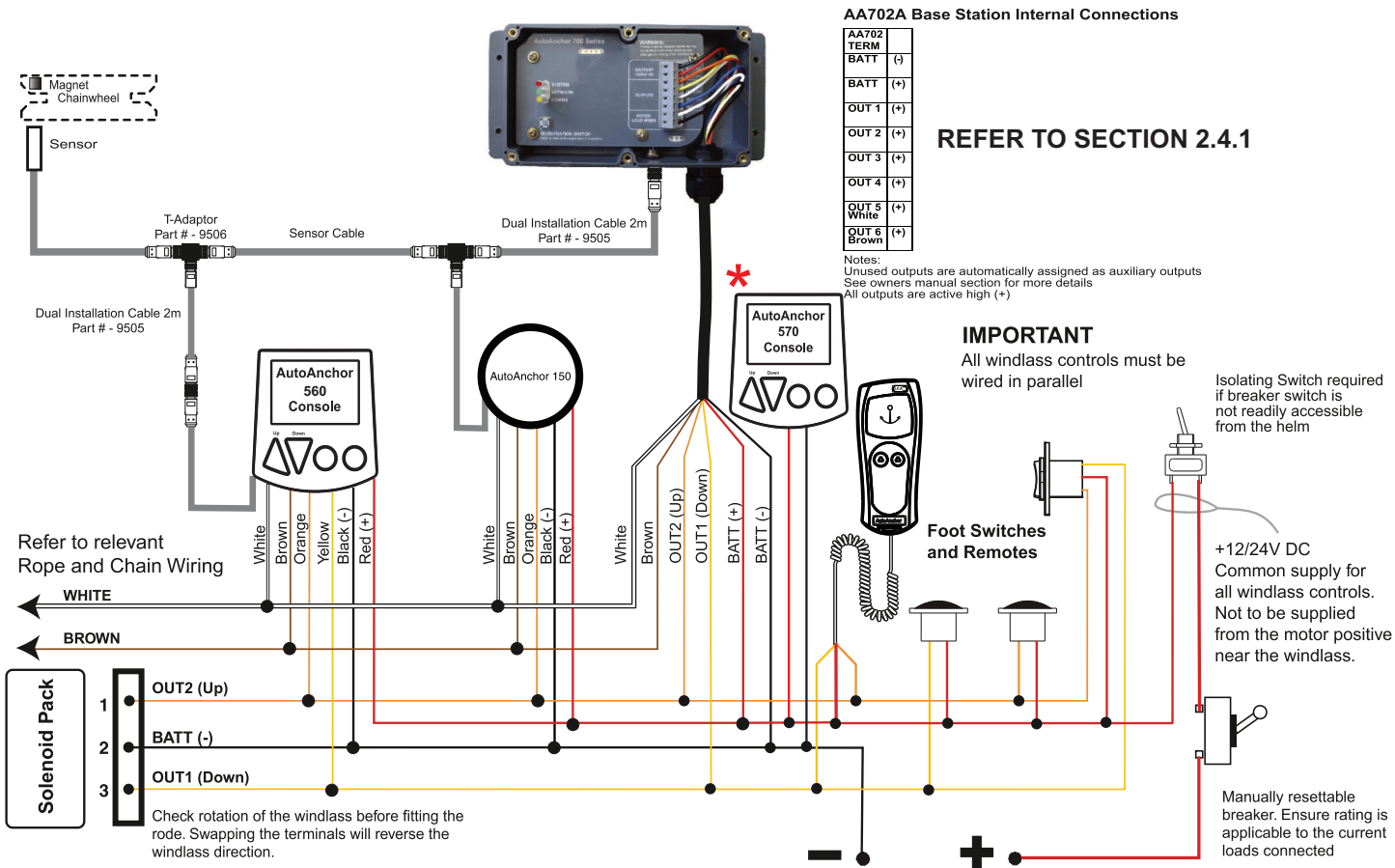

The * AA570 can also be connected directly into any 12v or 24v protected power supply

WARNING: Power must be disconnected during installation and when making any changes to wiring after installation

INSTALLATIONS MUST BE CARRIED OUT IN ACCORDANCE WITH USCG, ABYC, NMMA and BMEA REQUIREMENTS