

MEMBER
ABYC
Setting Standards for Safer Boating

2.1

TWO POINT ONE
ISO 9001

BAYSTAR™

CAPILANO™

SEASTAR™

INSTALLATION INSTRUCTIONS

AND OWNER'S MANUAL

www.seastarsolutions.com



SEASTAR™

Steering Cylinder Installation Manual
for Hydraulic Inboard and Sterndrive
Powered Vessels



*Before you do it your way,
please try it our way*

To the Installer and End User (Owner)

Thank you for choosing SeaStar Steering Systems by SeaStar Solutions. This Installation and Owner's Manual contains all the information that you and others will require for the safe installation and use of your steering system and **MUST** remain on board the boat. Throughout this manual, information for the safe installation and operation of the steering system will be distinguished in one of the following ways;

WARNING

Hazards or unsafe practices which could result in severe personal injury or death.

Failure to adhere to a warning may lead to loss of steering control. Loss of steering control may result in unpredictable boat behavior, leading to ejection from boat causing property damage, personal injury and/or death.

CAUTION

Hazards or unsafe practices which could result in minor injury or product or property damage.

NOTICE

Important information in regards to installation, use and maintenance of the steering components.

NOTICE

Marine Canada Acquisition Inc. DBA SEASTAR SOLUTIONS is referred to as SeaStar Solutions throughout this publication.

These safety alerts alone cannot eliminate all of the hazards that may be present while on the water. SeaStar Solutions recommends that all users of the steering system take an accredited 'boating safety course', follow safe boating practices and are made aware of the environment that they will be in.

Safety Information

The safe operation of the steering system is dependant upon proper installation and maintenance, common sense, safe judgment and the knowledge/expertise of the operator. Every installer/user of the steering system should know the following requirements 'before' installing/using the steering system.

If you have any questions regarding any of these warnings, contact SeaStar Solutions.

To reduce risk of severe injury or death. Always wear a Coast Guard Approved personal flotation device (PFD) and use an engine shut-off cord (lanyard).

Before installation

1. Read and understand the Installation and Owner's Manuals provided with your steering components.
2. Ensure that all components required to complete the installation are on hand (including hoses, fittings, oil and the proper tools required for the installation).
3. Substituting non SeaStar parts are not recommended as they may compromise performance/reliability.

Installation

1. Install components as directed in all Installation Manuals (including helm pumps, hoses and fitting kits).
2. DO NOT modify any component in any way without written consent from SeaStar Solutions.
3. Comply with all system ratings/regulations (boat/engine, U.S.C.G.).
 - Cylinder MUST be compatible with engine(s) installed.
 - Cylinder MUST be rated for use on the engine(s) installed.
 - Cylinder MUST be able to withstand rudder loads.
4. Confirm that there is no interference between the steering cylinder(s) and any other object by performing the following steps:
Stern drive applications:
 - a) With cylinder installed, turn steering wheel from hard over to hard over and confirm that no interference occurs.
 - If using external mount cylinders, confirm no interference with drive in UP/DOWN positions.
Inboard applications:
 - a) Confirm that cylinder(s) fully extend/retract prior to hitting any installed rudder stops.
5. Confirm that the steering cylinder can be fully stroked in both directions without stretching, chafing, rubbing and/or kinking of the hydraulic hoses.
6. Where required, confirm that extruded nylon tubing has NOT been substituted for SeaStar Steering Hose.
7. DO NOT use a wire coil type trim switch with a hydraulic steering system as the wire can wind up tight around the steering wheel shaft and prevent further steering.
8. Conduct System Proof Check as outlined on page 30 of this manual.

Safety Information Continued

Prior to every use

1. Check Fluid level in highest helm pump (see page 30 for proper fluid level setting).
2. Verify immediate steering response when turning steering wheel(s). (Ensure drive(s)/rudder(s) turns when steering wheel is turned.)
3. Visually inspect all steering hoses and fittings for wear, kinking and/or leaks.
4. Check for binding, loose, worn or leaking steering components.
5. Ensure operator(s) have taken an 'accredited boating course'.

DO NOT OPERATE BOAT IF ANY COMPONENT IS NOT IN PROPER WORKING CONDITION.

During use

1. WEAR A COAST GUARD-APPROVED PERSONAL FLOTATION DEVICE (PFD).
2. ATTACH ENGINE SHUT-OFF CORD (LANYARD) TO YOUR PDF.
3. Never allow anyone not familiar with the operation of the steering system operate the boat at any time.
4. Know and adhere to the operator restrictions for your area including;
 - Federal Laws/Regulations,
 - State Laws/Regulations and
 - Municipal Laws/Regulations.

DO NOT OPERATE BOAT IF ANY COMPONENT IS NOT IN PROPER WORKING CONDITION.

After use

1. Rinse off steering system thoroughly using 'fresh, clean water only'.
 - Cleaning fluids containing ammonia, acids or any other corrosive ingredients **MUST NOT** be used for cleaning any part of the hydraulic steering system.

Maintenance

1. Maintain steering system at a minimum of twice per year.
 - See Routine Maintenance, page 31 of this manual.

Keep our waters clean for all current and future users. Dispose of ALL fluids in accordance with your local regulations.

INTRODUCTION

Before proceeding with the installation, read THESE instructions and ALL other instructions included with the rest of your system (helm pumps, Power Assist etc). SeaStar Solutions cannot accept responsibility for installations where instructions have not been followed, where substitute parts have been used, or modifications have been made to our products. Warranty may be void if products other than SeaStar Solutions products are used within the system.

NOTICE

Due to a small amount of internal slip, a “Master Spoke” or “centered” steering wheel cannot be maintained with a hydraulic steering system. For best results, us an equal distance spoke steering wheel.

WARNING

DO NOT use a wire coil type trim switch with a hydraulic steering system. Wire coil can wind up tight around the steering wheel preventing further steering.

Index

Safety Information.....	i
Introduction	1
System Overview Diagram.....	2
Tools	3
Things You Need to Know	4
System Installation Overview.....	5
Cylinder Mounting: Inboard Ball Mount Models	6
Cylinder Mounting: Ball Joint Bracket Mount Cylinders.....	12
Cylinder Mounting: Sterndrive Engine Mount Cylinders	14
Hose and Tubing Installations	20
Additional Stations, Autopilots & SeaStar Power Assist Units	24
Manual Filling and Purging	25
Oil Level and System Proof Check	30
Routine Maintenance	31
Troubleshooting Guide	32
Technical Information	35
Parts List.....	36
Warranty.....	43

The following steering cylinders are covered within this manual.

HC1503-3, HC5303-3, HC5312-3, HC5313-3, HC5314-3, HC5319-3, HC5322-3, HC5323-3, HC5326-3, HC5328-3, HC5329-3, HC5330-3, HC5331-3, HC5332-2, HC5339-3, HC5373-3, HC5386-3, HC6324-3. HC5318, HC5319, HC5369, HC5373.

Typical Inboard Steering System

⚠ CAUTION

DO NOT attempt to install NPT pipe fittings directly into -3 helms or -3 steering cylinder hose fitting ports. Doing so will lead to irreparable damage to the helm/cylinder. ONLY use ORB hose fittings provided by SeaStar Solutions.

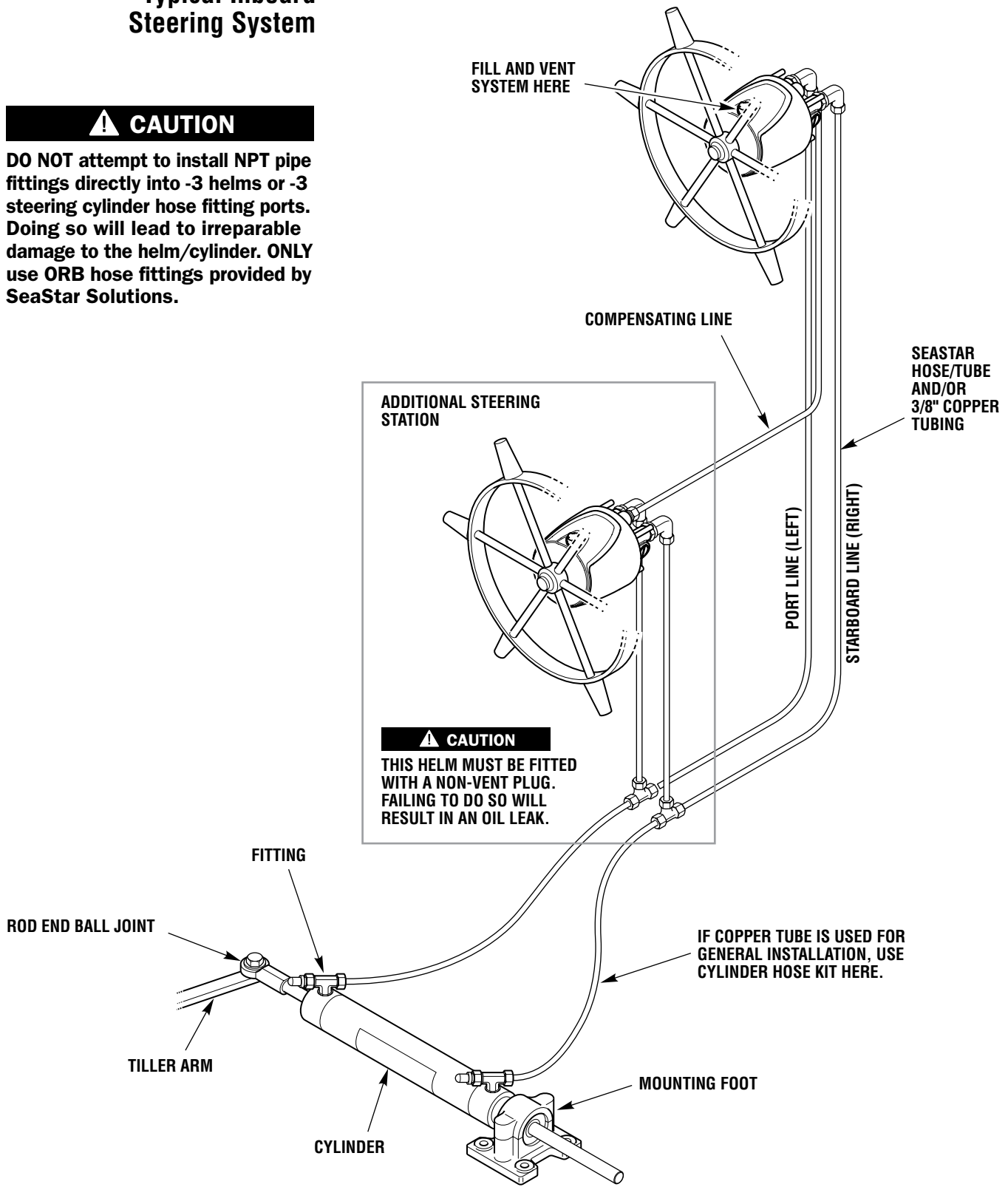

Figure 1. Overview.

TOOLS

Standard Helm Mounts

You will need the following tools to complete your installation.

- 3" (77 mm) diameter Hole Saw or Key Hole Saw, for use with Front Mount, Sport/Sport Plus Tilt helms.
- 5/16" (8 mm) dia. Drill.
- 7/16", 9/16", 5/8" and 3/4" Open End type Wrench/Spanner.
- 15/16" Socket.

Optional Helm Mounts

- Square Bezel Backmount, HA5418, 4-1/2" (115 mm) Hole Saw
- Round Bezel Backmount, HA5478, 4-3/8" (112 mm) Hole Saw
- Rear mount Helms, 1-1/6" (27 mm) drill
- Classic Tilt Helms, 4-1/2" (115 mm) Hole Saw
- 20° Wedge Kit HA5419

Additional Tools Needed

20° Mount Wedge

- 4" (102 mm) Key Hole or Sabre Saw
- 5/16" (8 mm) dia. Drill
- 1/2" Wrench/Spanner, Box or Open End type
- 7/16" Socket and Drive

Cylinder, ATM and TM Models

- 3/4" Wrench/Spanner, Box or Open End type, 2 required.

Cylinder, Ball Joint Bracket Mount Models

- 3/4" Wrench/Spanner, Box or Open End type, 2 required.

Cylinder, Model HC5328-3 (125-8EM)

- 1-5/16" Wrench/Spanner, Open or Adjustable type.

Cylinder, Other Models

- No special tools required.

CAUTION

Do not remove protective caps from fittings and fitting ports until hose or tube connections are made. Contaminants in the steering system may cause premature wear and steering malfunctions.

NOTICE

Disposing of excess, left over, or used fluid. If the original oil bottle is unavailable, dispose of the steering fluid in an environmentally conscientious manner, adhering to local and federal environmental regulations.

Always wear safety glasses and protective clothing when working around hydraulic fluid and components.

THINGS YOU NEED TO KNOW

⚠ WARNING

DO NOT use SeaStar PRO helms with ANY unbalanced steering cylinder. Use of a PRO helm with an unbalanced cylinder will lead to a lock up of the steering wheel preventing further steering control, resulting in collision with an obstacle causing property damage, personal injury and/or death.

⚠ CAUTION

SeaStar/SeaStar PRO Steering Hoses CANNOT be cut. Cutting these hoses will render them useless and a new hose will be required.

⚠ CAUTION

BEFORE beginning with this installation, confirm that ALL components have been acquired to complete the installation, including; helm pump(s), hose and tube, oil, pipe sealant and any other component required. DO NOT USE Teflon tape. ONLY use a “liquid”, Teflon based pipe sealant (such as Loctite® 542).

⚠ CAUTION

Take EXTREME care not to allow any foreign material or contamination to enter the hydraulic steering system. Contamination is the main cause of a hydraulic system to wear and or fail. Protect ALL hose/tube ends until ready to make final connection to fitting.

⚠ WARNING

Follow the maintenance procedures outlined on page 31 of this manual as well as ALL other manuals included with the other components of your steering system. Following these procedures, in the time frame noted will keep you and your passengers safe from the dangers that are present on the water. Failure to adhere to ALL maintenance procedures included in ALL Installation and Owner’s Manual may result in loss of steering control. Loss of steering control may lead to unpredictable boat behavior, leading to a collision with an obstacle and/or ejection from the boat, resulting in property damage personal injury and/or death.

Before Starting

Study this manual and ALL other manuals provided with your SeaStar Steering System carefully and thoroughly to familiarize yourself with all of the components and their intended or required mounting locations. Ensure there is adequate space available for installation of ALL components, hydraulic lines and easy access for service. It is good practice to mount all components first, before running hoses; this ensures the least chance of an error in hose/tube to fitting connections. If you must run hoses first a system of marking the various lines must be used. ALL hose/tube ends MUST be closed off with tape or similar material to prevent contamination. Read ALL BOLD print text, notes, cautions and warnings; reading these now will help prevent unexpected surprises during the installation.

These instructions have been made as complete as possible, but as brief as practical. If you have any questions please phone SeaStar Solutions, Technical Support @ 604.248.3858

SYSTEM INSTALLATION OVERVIEW

STEP 1 System Installation

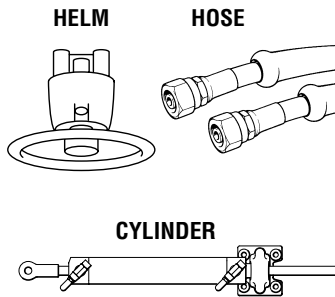

- Install your SeaStar helm pump(s) onto the dash using the installation instructions provided with your helm pump(s).

⚠ WARNING DO NOT use a SeaStar PRO helm with an unbalanced cylinder.

- Install steering cylinder as per the instructions on the following pages.

NOTICE Ensure that you follow the installation instructions for YOUR Steering Cylinder.

- Install hose/tube as per the plumbing diagrams shown on page 22.

STEP 2 Filling and Purging Procedures

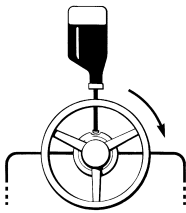

- Manual purging: Refer to page 25 of this manual for bleeding details.
- Power Purging: Refer to Power Purge Installation Manual.

STEP 3 System Proof Check

- **⚠ WARNING** The System Proof Check shown on page 30 of this manual **MUST** be completed after installation. Doing so will ensure the safe operation of your steering system. Any fault (leaks or malfunction) will present itself during this check. Failure to perform this check may result in loss of steering control. Loss of steering control may lead to unpredictable boat behavior, leading to a collision with an obstacle and/or ejection from the boat, resulting in property damage personal injury and/or death.

CYLINDER MOUNTING

Inboard Ball Mount Models

General

Proper cylinder mounting is CRITICAL to the successful operation of your hydraulic steering system. An incorrectly installed cylinder WILL lead to rapid seal and bearing wear as well as non-repairable damage.

Select the diagram and dimensional data that corresponds with your cylinder model. Note, not all possible cylinder mounting configurations are shown, however, all necessary dimensions are shown regardless of mounting configurations.

⚠ CAUTION

If installing rudder stops, ensure that the cylinder(s) reach hard-over BEFORE rudder stops are engaged.

⚠ WARNING

Where applicable, cylinders should be secured with thru bolts, NOT with lag screws. Failure to adhere to this warning may result separation of steering components leading to loss of steering control, which may result in unpredictable boat behavior, leading to a collision with an obstacle and/or ejection from the boat, resulting in property damage personal injury and/or death.

⚠ CAUTION

Cylinder hose/bleeder fittings must always be installed in the uppermost position. If this is not possible the cylinder must be disconnected from mount to allow the bleeder fittings to be in the up-right position, then, once all air is removed the cylinder can be re-installed. Leaving air in the system will drastically affect performance of your steering system.

⚠ CAUTION

Protect cylinder shafts from nicks and scratches. A damaged cylinder shaft can not be repaired and a new cylinder will need to be purchased.

All parts used are corrosion resistant, however with extended operation under extremely corrosive conditions, corrosion may occur and affected parts should be replaced.

In order to avoid excess steering loads and to optimize steering performance, outdrive trim tabs must be adjusted in accordance with the engine manufacturer's instructions for specific boat/motor combinations. Failure to do so will drastically change the performance and handling characteristics of your boat.

Inboard Aluminum Ball Mount Cylinder Models

- HC5312-3
- HC5313-3
- HC5314-3
- HC5319-3
- HC5373-3

To minimize side loading of the cylinder rod and maximize cylinder performance, it is important that the cylinder is installed as instructed. The cylinder should be parallel to the transom, tiebar, or keel line (depending on mounting configuration) when the cylinder rod is fully extended or retracted.

1. Determine the mounting location for the cylinder. The method depends on whether the tiller arm length is already set:
 - a) **Tiller arm length is not set:** Determine the tiller arm length (dimension 'A') and foot bracket location (dimensions 'B' and 'C') from table 1. Figure 3 and figure 4 illustrate how to use these dimensions to locate the cylinder.
 - b) **Tiller arm length is already set:** draw an imaginary line through the tiller arm hole at both hard over positions and align the cylinder with this line, as shown in figure 2. Angles X and Y should be the same at both hard over positions. Alternatively, you can calculate dimension B from the equation below:

$$B = A \sqrt{1 - \left(\frac{.5S}{A}\right)^2} - (D/2)$$

Where:

A is the tiller arm length

S is the stroke of the cylinder

D is the bracket hole spacing (see figure 3 and figure 4)

Model	Bore	Stroke	Total Steering Angle							
			50°		60°		70°		80°	
			A	B	A	B	A	B	A	B
HC5312-3 C:18.88"	1.25"	7"	8.28"	6.38"	7.00"	4.94"	6.10"	3.87"	5.45"	3.05"
			Torque 7806 in-lb		Torque 6304 in-lb		Torque 5198 in-lb		Torque 4337 in-lb	
HC5313-3 C:18.88"	1.35"	7"	8.28"	6.38"	7.00"	4.94"	6.10"	3.87"	5.45"	3.05"
			Torque 8819 in-lb		Torque 7123 in-lb		Torque 5873 in-lb		Torque 4901 in-lb	
HC5314-3 C:18.88"	1.50"	7"	8.28"	6.38"	7.00"	4.94"	6.10"	3.87"	5.45"	3.05"
			Torque 10943 in-lb		Torque 8838 in-lb		Torque 7287 in-lb		Torque 6081 in-lb	
HC5319-3 C:20.10"	1.75"	7"	8.28"	5.51"	7.00"	4.06"	6.10"	3.00"	5.45"	2.17"
			Torque 15206 in-lb		Torque 12281 in-lb		Torque 10126 in-lb		Torque 8450 in-lb	
HC5373-3 C:23.10"	1.75"	9"	10.65"	7.65"	9.00"	5.79"	7.85"	4.43"	7.00"	3.36"
			Torque 19551 in-lb		Torque 1579 in-lb		Torque 13020 in-lb		Torque 10865 in-lb	

Table 1.

HYDRAULIC STEERING

INBOARD BALL MOUNT

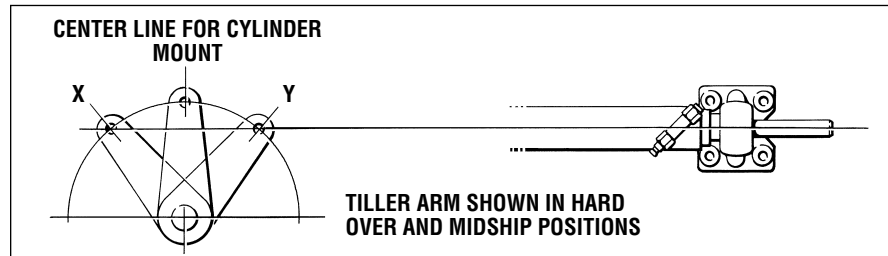

Figure 2.

HC5312-3, HC5313-3, HC5314-3

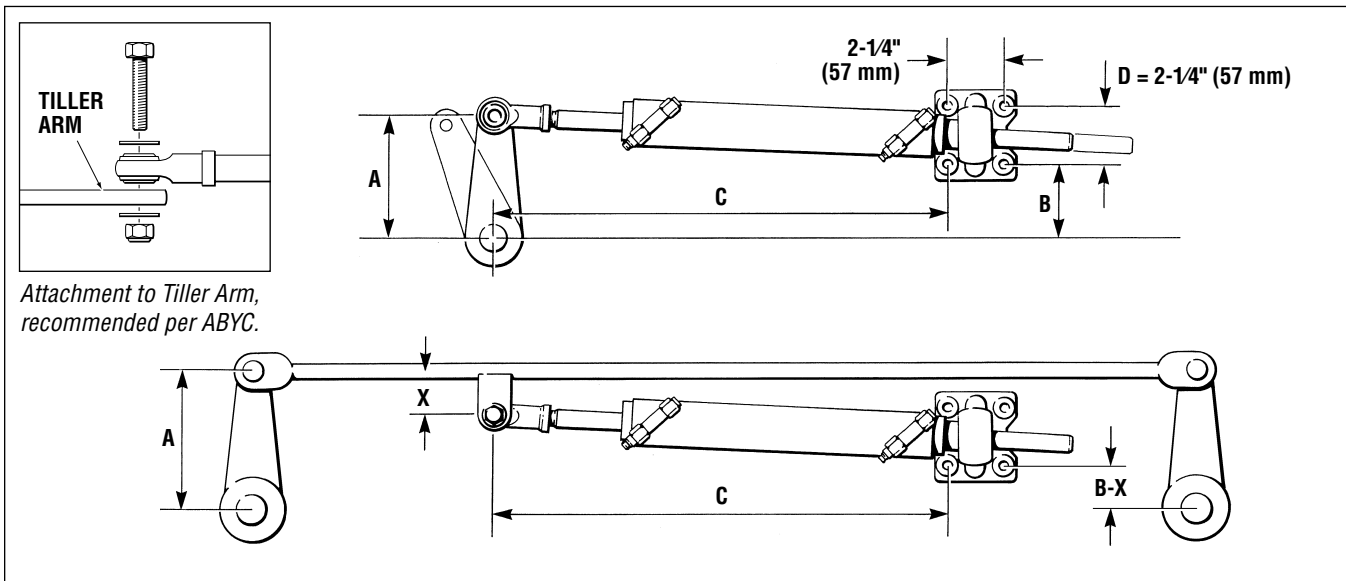

Figure 3.

HC5319-3, HC5373-3

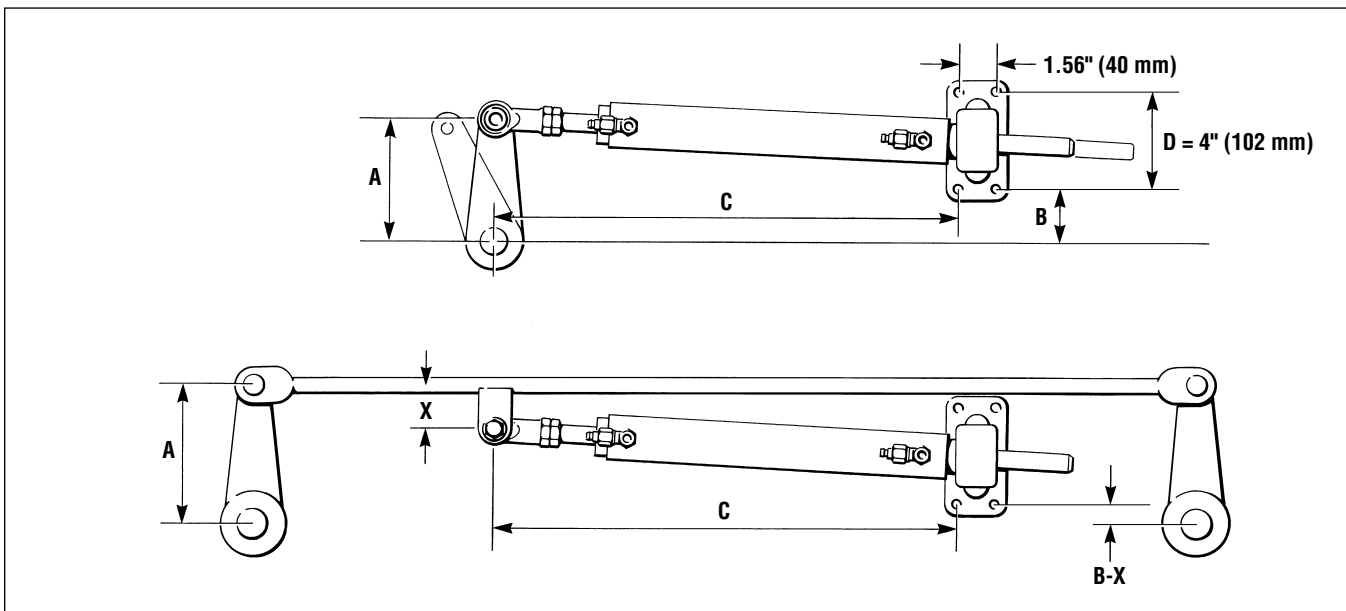

Figure 4.

2. Fasten the rod end to the tiller arm using the supplied hardware. Torque the nut according to the chart on page 35. If you use an anti-seize lubricant, be sure to reduce the torque as instructed. There must be at least two threads protruding past the nylon locking insert on the nut.
3. Place mounting foot in the location determined in step 1. Shim under the foot as necessary to make the cylinder as level as possible. Vertical misalignment will accelerate cylinder wear.

⚠ CAUTION

There is NO adjustment for centering cylinder after installation. Correct mounting is critical at this time.

4. Through-bolt the mounting foot to a substantial mounting structure using stainless steel (type 304 or 316) capscrews, washers, and self-locking nuts. Orient the fasteners such that if the nut were to vibrate loose the fastener would not fall out. Cylinders with 1.5" and smaller bores require 5/16" (8 mm) fasteners, cylinders with 1.75" bore require 3/8" (10 mm) fasteners. Torque the fasteners according to the chart on page 35.
5. Before making hose connections, remove the caps from the fittings and swing the rudder(s) back and forth to confirm there is free movement of the cylinder. Check that there is no binding anywhere through the stroke of the cylinder.

⚠ WARNING

Any binding and or interference MUST be corrected prior to use. Failure to do so may lead to separation of components and/or prevention of steering control, leading to unpredictable boat behaviour and/or a collision with an obstacle and/or ejection from vessel resulting in property damage, personal injury and/or death.

Jet Drive Cylinders:

HC1503-3 (BA150-3ATM),
HC5303-3 (BA125-3ATM)
HC6324-3 (BA150-3.5ATM)

These cylinders are generally used in jet drive applications. ALL warnings, cautions and notices shown on page 6 and this page are to be followed to ensure safe operation of the steering system. SeaStar Solutions does not make a recommendation as to the installation to a jet drive. The measurements shown below are used to assist with the installation.

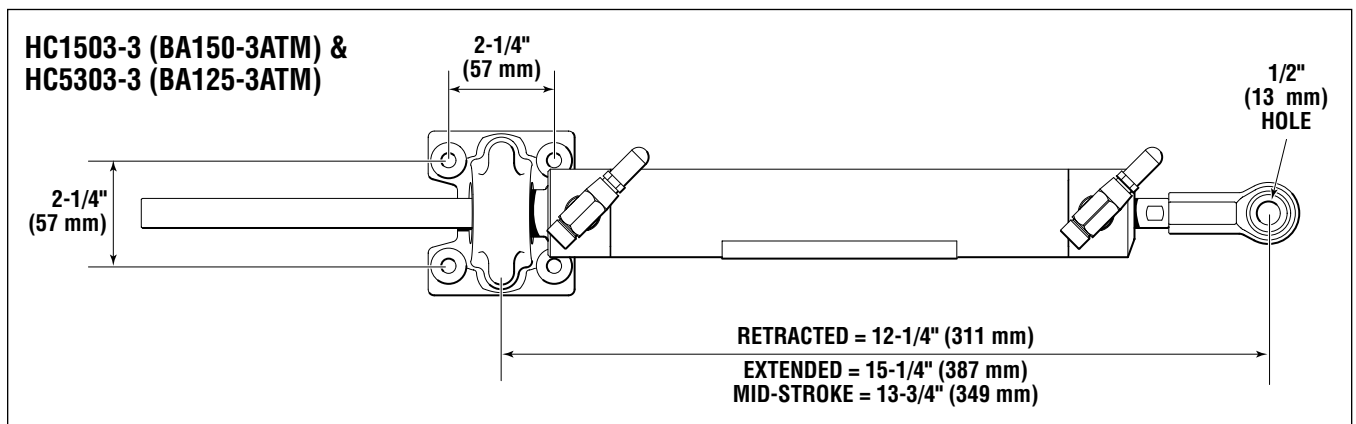

Figure 5.

HYDRAULIC STEERING

INBOARD BALL MOUNT

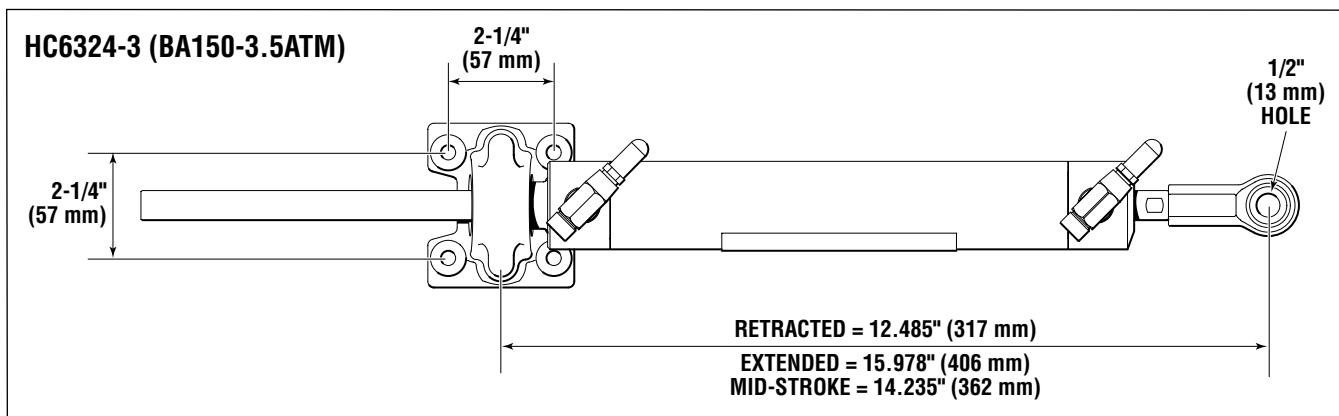

Figure 6.

Inboard Brass Ball Mount Cylinder Models:

HC5318 (BA150-7TM)
HC5319 (BA175-7TM)
HC5369 (BA150-9TM)
HC5373 (BA175-9TM)

1. To achieve MAXIMUM cylinder performance it is suggested that an imaginary line is drawn through the tiller arm hole at both hard over positions (see figure 7), this will create the "cylinder center line". With the tiller arm at hard over positions, angle X and Y should be the same.

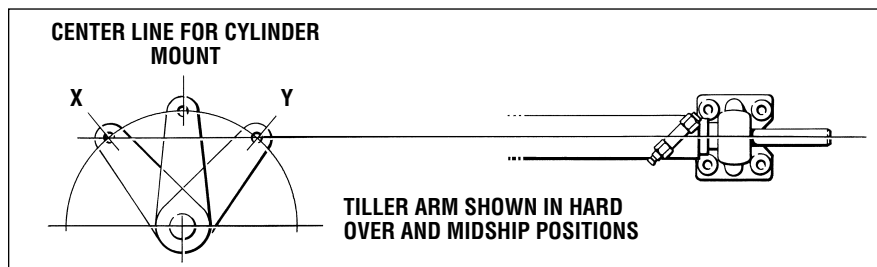

Figure 7.

2. Set rudder(s) in the fore and aft position and then attach rod end ball joint to the tiller arm or tiebar.
3. Remove caps from cylinder hose fittings.
4. Extend cylinder rod to arrive at 21" (533 mm) or 23-1/4" (591 mm) from center of rod end ball joint to the center of the mounting foot. See figure 8.

NOTICE

In order to obtain a correct push and pull angle between the tiller arm and cylinder, or tiebar and cylinder, the cylinder should be parallel to the transom, tiebar or the keel line (depending on your mounting configuration) when cylinder rod is fully extended (out) or fully retracted (in).

⚠ CAUTION

There is NO adjustment for centering cylinder after installation. Correct mounting is critical at this time. Total cylinder travel is 7" or 9" (depending on your cylinder model)

NOTICE

For twin rudders, the cylinder may be mounted directly to the tiebar or to one of the tiller arms. ENSURE all measurements remain the same as if mounting to a rudder arm.

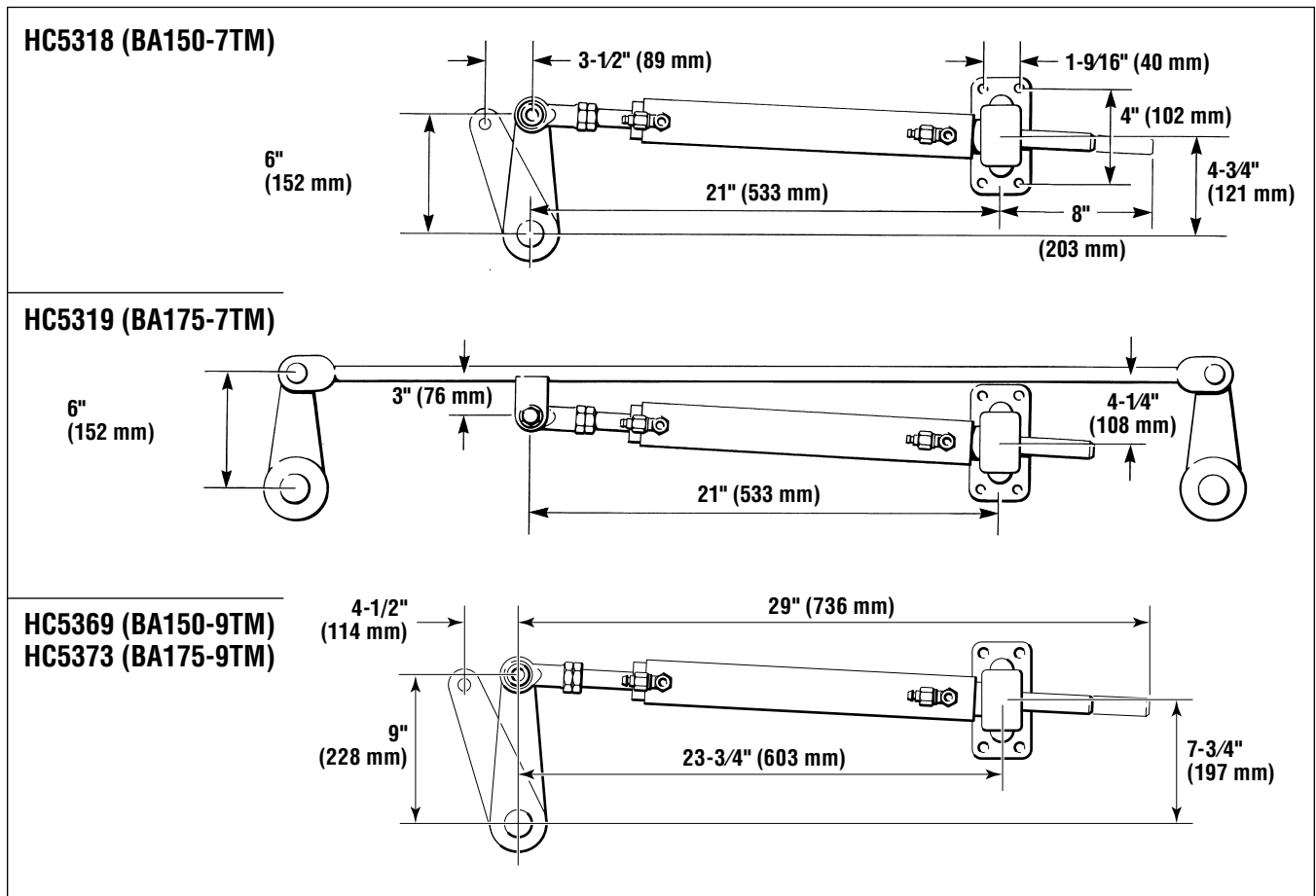

Figure 8.

5. Secure mounting foot to transom or mounting bracket using four 3/8" (10 mm) Grade 5 bolts (corrosion resistant) and self-locking nuts.
6. BEFORE final hose/tube connection, swing rudder(s) back and forth to ensure free movement of cylinder and that there is no binding of the rod end ball joint.

⚠ WARNING

Any binding and or interference MUST be corrected prior to use. Failure to do so may lead to separation of components and/or prevention of steering control. Separation of components or loss of steering control may lead to a collision with an obstacle and/or ejection from vessel resulting in property damage, personal injury and/or death.

⚠ CAUTION

The cylinder ball mount allows up to 15° of movement MAX. Any movement beyond 15° will result in premature seal and/or bearing wear.

Ball Joint Bracket Mount Cylinders

NOTICE

These cylinders replace the Hynautic K-18 (HC5322-3) and K-19 (HC5323-3) steering cylinders.

CAUTION

These cylinders are not intended for use on any racing and/or aggressive type applications.

Important Notes

1. At ALL times protect cylinder shafts from nicks and scratches. A damaged cylinder shaft cannot be repaired and MUST be replaced.
2. To achieve MAXIMUM performance, cylinder is to be mounted at a right angle (90°) to the rudder arm when in the center position (refer to Figure 9 below).
3. Ball joint connections allow for no-load pivoting and minor misalignment. Ball joint connections are NOT designed to handle steering loads when significantly misaligned.
4. Mounting area MUST be able to withstand significant forces in excess of **2000 lb.** There must be NO binding or interference of the ball joints at any point in the steering arc.

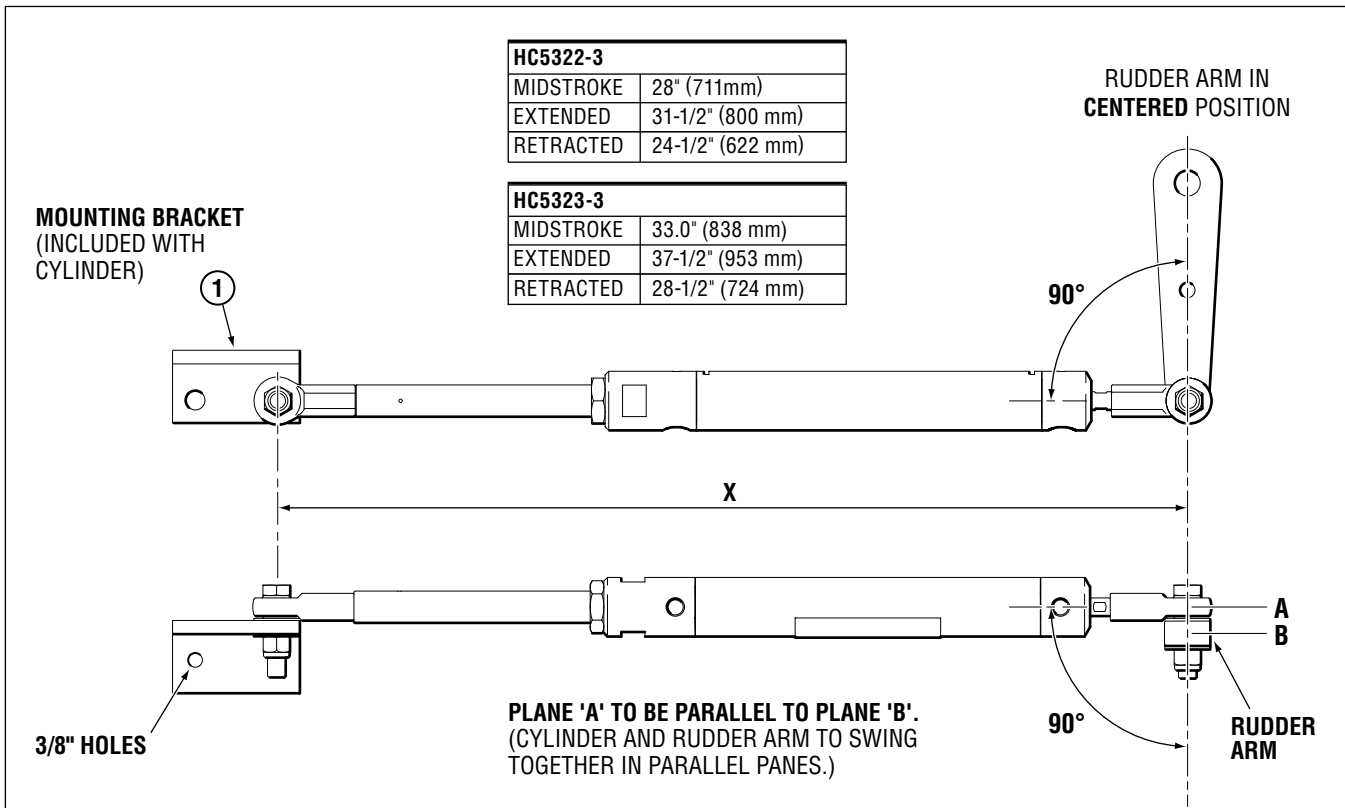

Figure 9. Correct Cylinder to Rudder Arm Mounting Orientation.

Cylinder Mounting – Rod End to Tiller Connection

1. Determine rudder arm hole location using Table 1 below.
2. Lightly grease the bolts being installed into the rudder arm and mounting bracket.
3. Assemble 1/2" x 2-1/4" bolt (item 2) and washers (items 3) into rod end assembly and rudder arm, as shown in Figure 10.
4. Torque nuts (item 4, Figure 10) to 43 ft-lb (58.3Nm).
5. Place rudder in midstroke position and extend cylinder to mid stroke (see Figure 9).
6. Temporarily install the other rod end into the mounting bracket (item 1, Figure 9). Using the bracket as a template, mark off the positions of the two 3/8" holes on the mounting surface.
7. Once the mounting location is chosen and marked, confirm that there are no obstructions on the opposite side of the backing surface and drill the required mounting holes.
8. Mount the bracket (item 1, Figure 9) with through bolts, washers and nuts (not supplied by SeaStar Solutions). DO NOT USE LAG BOLTS.
9. Attach rod end to mounting bracket as described in Steps 3 & 4.
10. BEFORE final hose/tube connection, swing rudder back and forth to ensure free movement of the cylinder and that the ball joint connections are not binding.

⚠ WARNING

Any binding and/or interference MUST be corrected prior to use. Failure to do so may lead to separation of components and/or prevention of steering control. Separation of components and/or prevention of steering control may lead to unpredictable boat behavior resulting in property damage, personal injury and/or death.

INBOARD RUDDER ARM HOLE LOCATION		
Total Rudder Arc	Dimension – Center of Rudder arm to Center of bolt	
	HC5323-3 (9"stroke)	HC5322-3 (7" stroke)
60 degrees	9"	7"
70 degrees	8"	6"

Table 1.

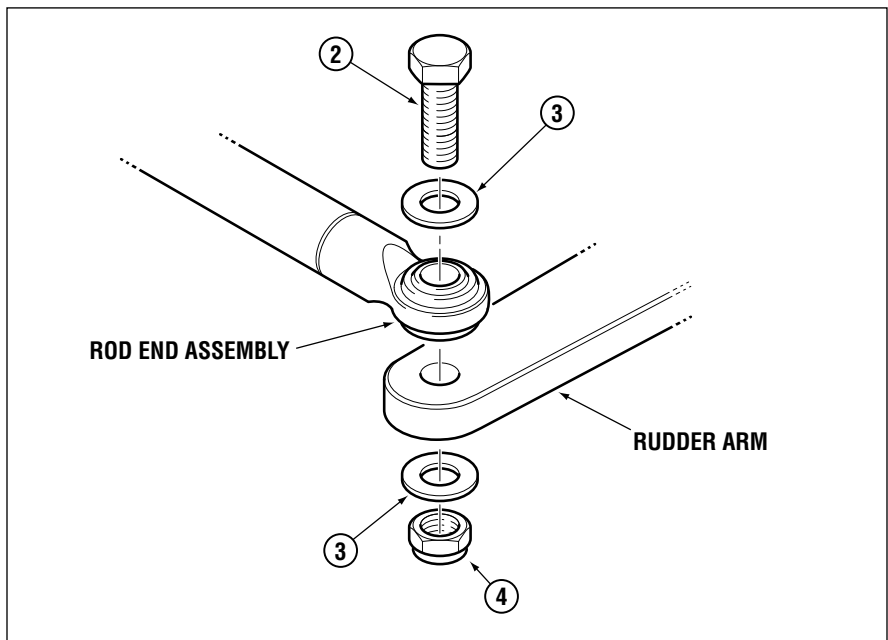

Figure 10. Attaching Rod End Assembly to Rudder Arm.

Sterndrive Engine Mount Cylinders

! WARNING

DO NOT use SeaStar PRO helm(s) with an unbalanced cylinder. Using a PRO helm with an unbalanced cylinder WILL lead to steering wheel “lock-up”. Lock-up may lead to collision with an obstacle resulting in property damage, personal injury and/or death.

NOTICE

Sterndrive cylinders are designed for use, in conjunction with, the engine manufacturer's power steering system. DO NOT Install into an application that does not use the engine manufacturers power steering.

General

- 1.** A support tube and/or cable support tube provided by the engine manufacturer **MUST** be used for these three steering cylinders. These cylinders are mounted to the sterndrives support/tube guide support in the same manner as a steering cable.
- 2.** Thoroughly lubricate support tube/cable guide tube, and cylinder rod with a high quality, anti-corrosive type marine grease (such as OMC Triple Guard or equivalent) **BEFORE** mounting cylinder to support tube.
- 3.** Slide well greased cylinder rod into and through well greased support/cable guide tube and thread cylinder fully onto support tube as shown below.

Sterndrive Engine Mounted Power Assisted Steering Models

HC5328-3 (125-8EM)
 HC5329-3 (128-8VEM)

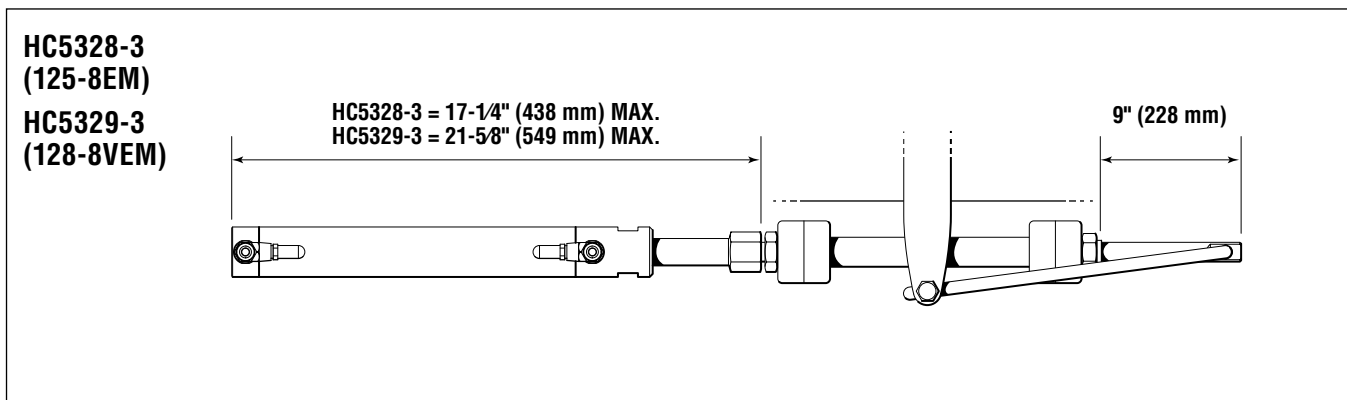

Figure 11. HC5328-3 (125-8EM) and HC5329-3 (128-8VEM), **NOT for use with SeaStar PRO helm(s).**

HC5331-3 (92VPS)

Referring to Figure 12 please observe the following:

- Rotate Cable Tube item 1 into threads of Item 2 until tight.
- Torque setscrew (item 7) to 90 in-lbs and tube insert (item 8) until tight.
- Item 3 must pass through items 4 and 5 before being secured by Item 6.
- Always mount cylinder in lower mount position of item 2 and without spacer item 9, unless mechanical interference prevents you from doing so.
- If using upper mount position, install spacer, item 9 below item 4.

⚠ CAUTION

Cut Clevis Pin, (item 3 Figure 12) to a length of 2" when mounting cylinder in lower position.

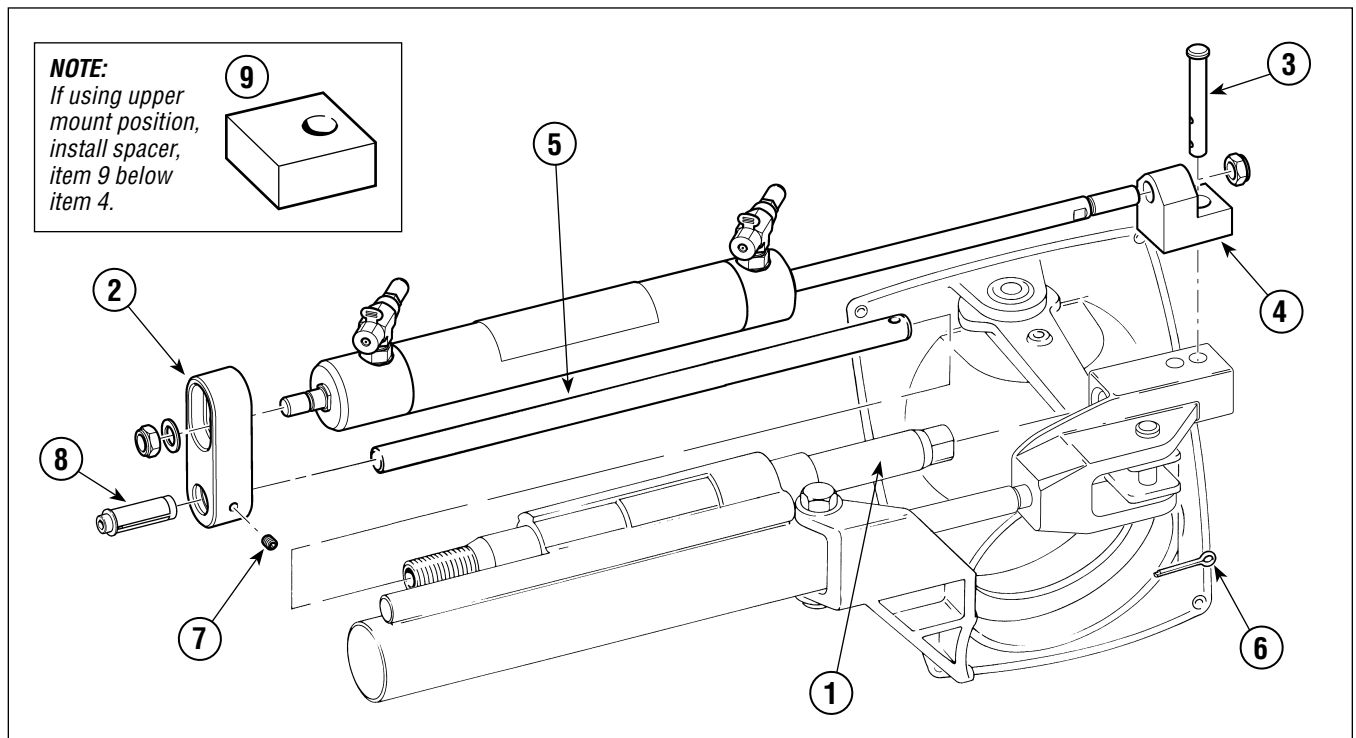

Figure 12. HC5331-3 (92-VPS), **NOT for use with SeaStar PRO helm(s).**

NOTICE

The SeaStar HC5331-3 steering cylinder is **NOT** compatible with some early model power steering rams. Although the cylinder will still mount to these rams, loss of articulation and possible damage to the steering ram may result. Please identify your power steering cylinder by comparing your clevis bracket to the 4 drawings shown below. The HC5331-3 **IS** compatible with units identified by figures 10 to 12, it is **NOT** compatible with the clevis bracket shown in figure 16.

HYDRAULIC STEERING

STERNDRIVE

NOTICE

ALWAYS INSTALL CYLINDER HC5331 IN THE OUTER HOLE

SHOWA
(LATE MODEL)

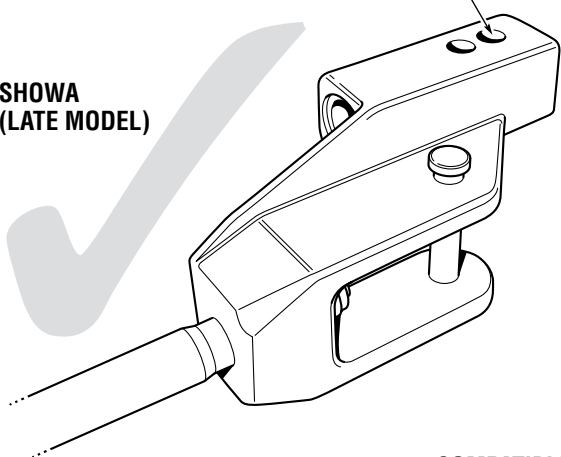

COMPATIBLE

Figure 13.

HOERBIGER

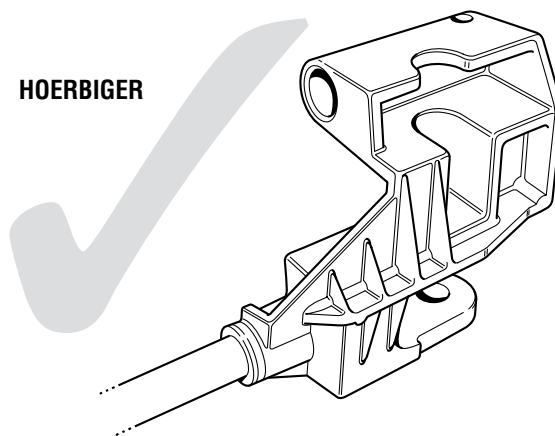

COMPATIBLE

Figure 14.

SEASTAR

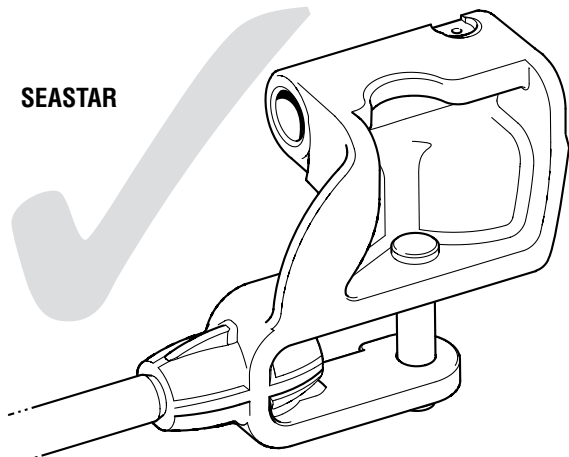

COMPATIBLE

Figure 15.

SHOWA
(EARLY MODEL
PRE 1992)

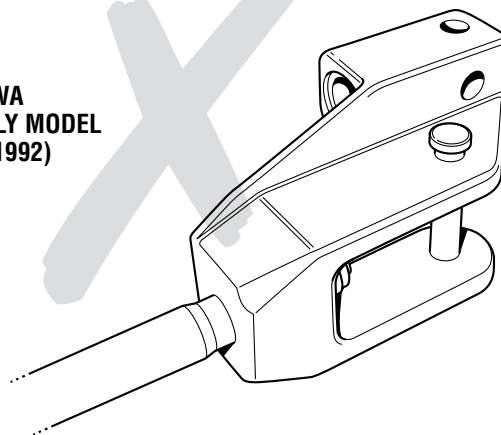

NOT COMPATIBLE

Figure 16.

HC5339-3 (125-6.5EM) Installation Instructions

Mercury Bravo I and II ONLY

1. Move the main steering ram to the fully retracted position.
2. Insert the long rod of the HC5339-3 cylinder into the clevis bracket until the through hole in the rod is aligned with the hole in the clevis bracket. Refer to figure 17.
3. Insert the 1/4" NF socket cap screw through the hole and install the shoulder nut. Torque to 72 in-lb.
4. Extend HC5339-3 cylinder as required and insert the short rod into the tilt tube as shown in figure 18.
5. Tighten the large mounting nut to 150 in-lb. Use wrench flats to stop the tilt tube from turning.
6. Install hoses and purge the system as shown on page 25.

⚠ WARNING

If Mercruiser power steering fails, service unit immediately or complete loss of steering may result.

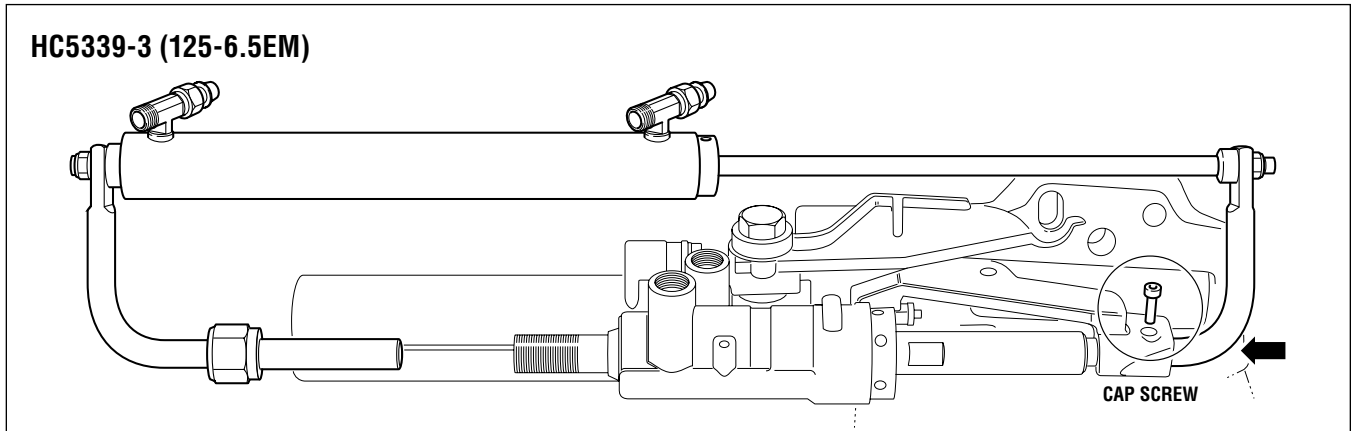

Figure 17.

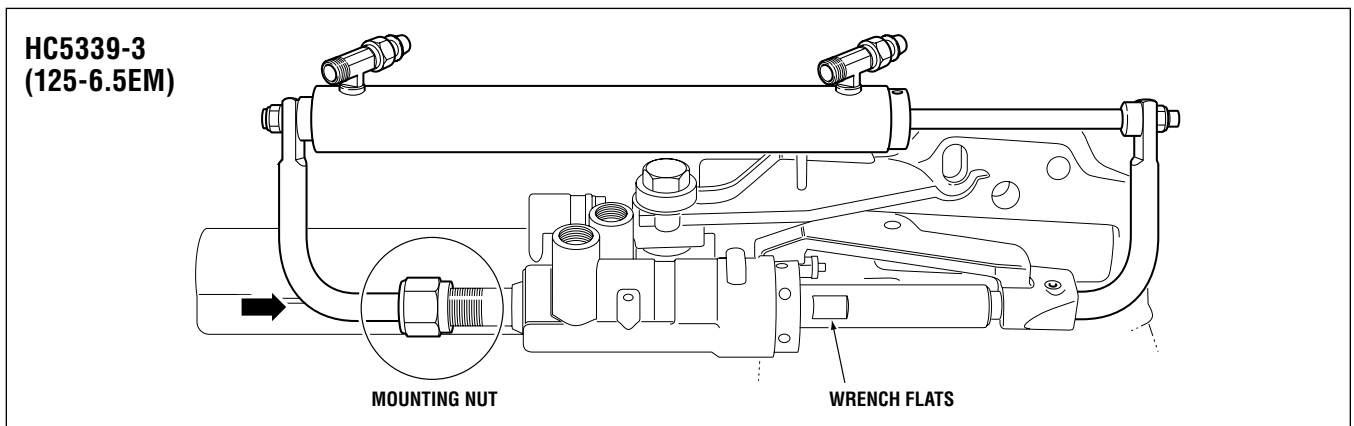

Figure 18.

Sterndrive Engine mounted, NON-Power Steering models:

HC5330-3 (BA125-8EMV)
Support Tube Mount

A Support Tube Mount – Requires support/cable tube from engine manufacturer for installations.

NOTICE *HC5326-3 is designed for use with 1984 – DATE Mercruiser and MOV Cobra NON-Power Assisted steering sterndrives (OMC Cobra requires SeaStar part# HA5424 to complete installation). DO NOT USE on a power assisted application.*

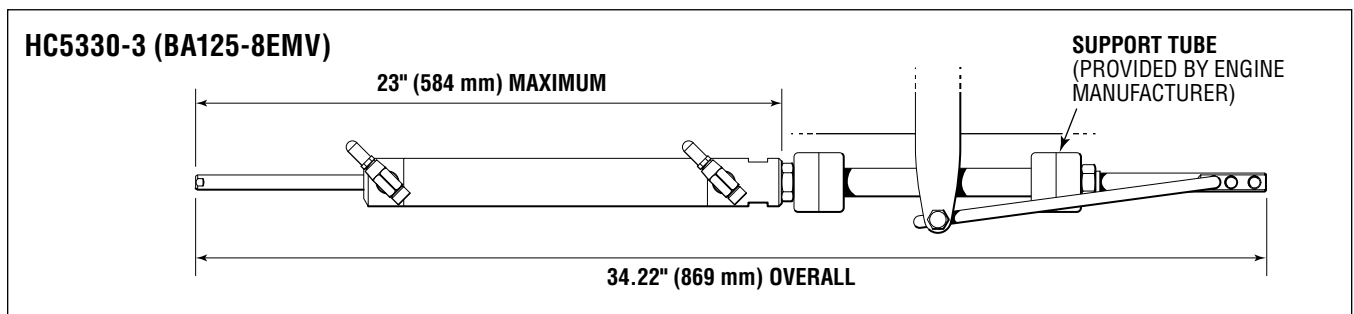

Figure 19. HC5330-3 (BA125-8EMV), manual, non-power steering.

HYDRAULIC STEERING

STERNDRIVE

HC5326-3 (BA150-7EM) *Transom Bracket Mount*

A Transom Bracket Mount – Mounts directly to the transom bracket and tiller arm.

This cylinder is designed for use with 1984 to date Mercruiser, and OMC Cobra non power assisted steering sterndrives (OMC Cobra requires SeaStar part HA5424). Sterndrives equipped with optional power assist steering require Cylinder Model 125-8EM.

NOTICE

Mastry Engine part # SUN144 is required to complete cylinder connection to Mercruiser sterndrives. This part is not available from SeaStar Solutions.

⚠ CAUTION

When connecting the cylinder to a Mercruiser the two washer spacers must be installed between the cylinder and mounting bracket.
When connecting the cylinder to an OMC Cobra, the two bushings must be inserted to the cylinder mounting holes.

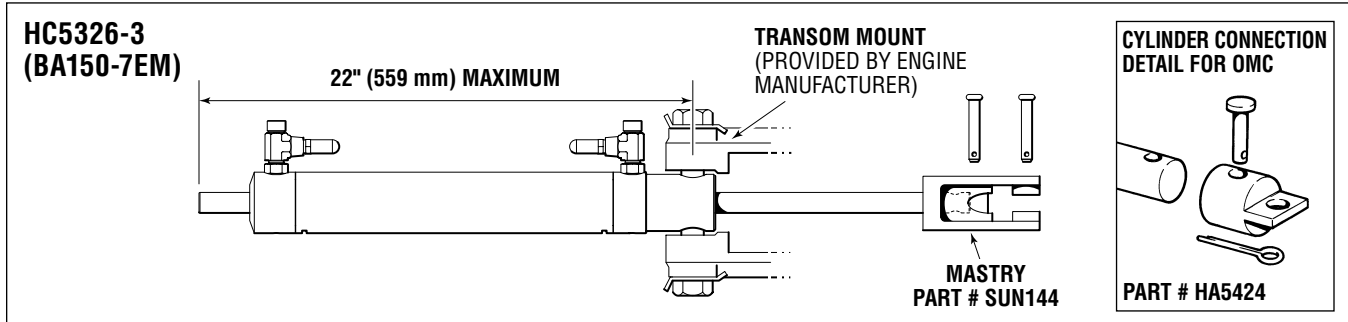

Figure 20. HC5326-3 (BA150-7EM), manual, non-power steering.

HC5332-2 (BA135-7EM) *Transom Bracket Mount*

A Transom Bracket Mount – Mounts directly to the transom bracket and tiller arm.

NOTICE HC5332-2 requires the use of SeaStar OUTBOARD hoses ONLY.

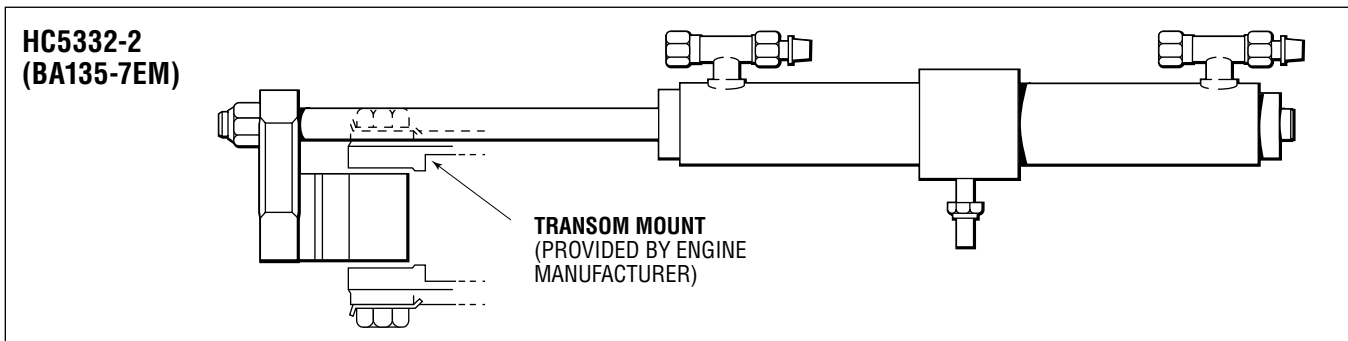

Figure 21. HC5332-2 (BA135-7EM) manual, non-power assist.

NOTICE

For cylinder model HC5332-2 If engine outdrive is NOT equipped with a torque tab on the underside of the lower leg, one **must** be installed to reduce prop torque.

⚠ CAUTION

HC5332-2 cylinder MUST use SeaStar Outboard Hoses. DO NOT install extruded nylon tubing or copper tubing directly to this cylinder.

HC5386-3 (150-7EM)

Transom Bracket Mount

⚠ CAUTION

MUST NOT be used with SeaStar PRO helms.

A Transom Bracket Mount – Mounts directly to the transom bracket and tiller arm.

This cylinder is designed to work with Select Volvo, Yanmar, and Mercury marine sterndrives.

1. Install steering cylinder (item 1) onto transom bracket using the mounting hardware provided with your transom bracket. Liberally grease all pivot surfaces with a quality marine grease.

Note: Use provided adapter bushings when transom bracket uses 1/2" trunnion pins.

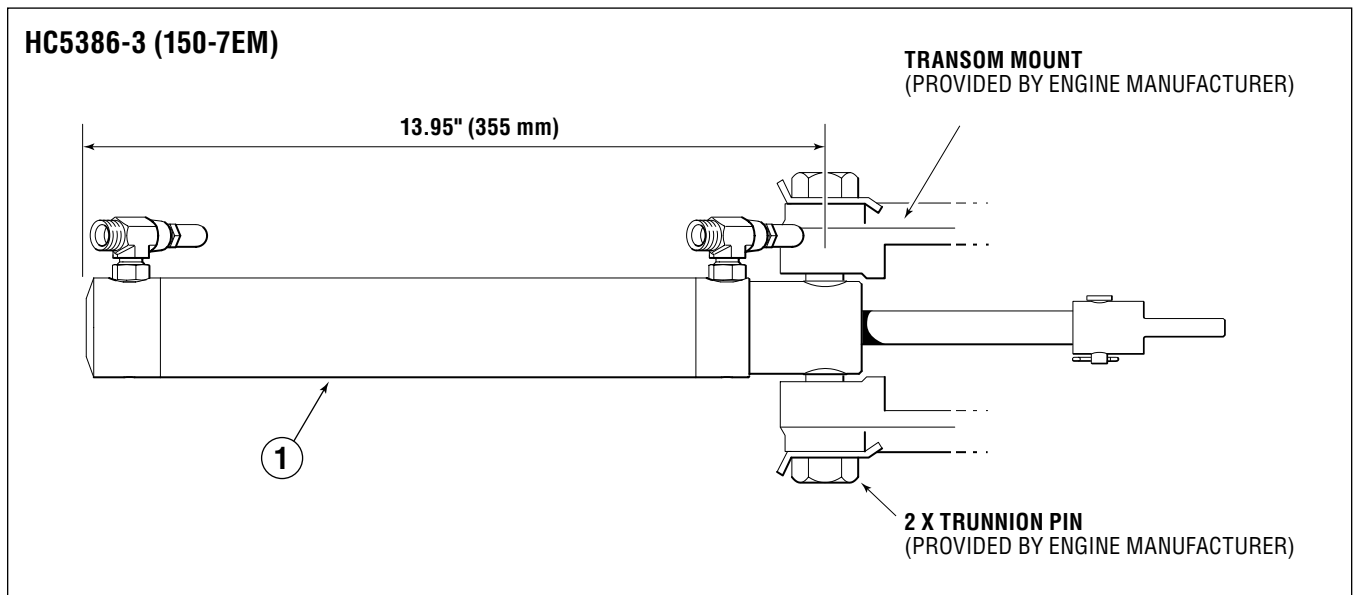

Figure 22. HC5386-3 (150-7EM) select power and non-power assisted applications. **MUST NOT** be used with a PRO helm.

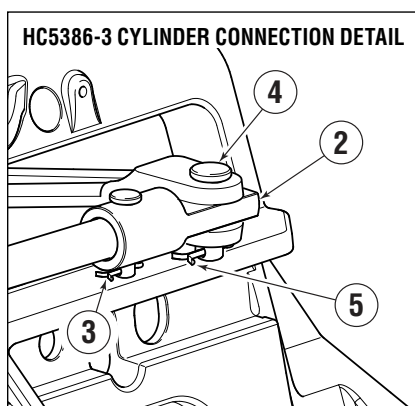

Figure 23.

2. Ensure the supplied cylinder clevis (item 2) is installed onto the end of the steering cylinder and the cotter pin (item 3) is installed with the prongs bent to avoid separation.

3. Connect steering cylinder to out drive steering arm using the supplied clevis pin (item 4) and supplied cotter pin (item 5). Bend cotter pin ends to prevent separation. Liberally grease all pivot surfaces with a quality marine grease.

Note: Both 1/2" and 3/8" tiller pins are provided. When using the 3/8" tiller pin place the associated adapter bushing in the clevis.

4. Remove caps from cylinder hose fittings and swing the tiller(s) back and forth to ensure free sterndrive movement. Ensure there is no interference with the cylinder.

5. Connect hoses and follow purge and bleed procedure on page 25.

⚠ WARNING

Failure to ensure proper installation of the cotter pin may lead to separation of components resulting in loss of vessel control.

HOSE AND TUBING INSTALLATIONS

General

Proper steering hose/tube is required for the best performance and safe operation of your steering system. Use of a hose/tube other than that recommended by SeaStar Solutions may drastically effect performance and the safe operation of your system. SeaStar Solutions cannot be responsible for ANY consequences resulting from the use of a substitute tube or hose.

WARNING

Use of a substitute hose and/or tube may lead to hose breakage or rupture resulting in loss of steering control. Loss of steering control may lead to unpredictable boat behavior and/or a collision with an obstacle and/or ejection from boat, resulting in property damage, personal injury and/or death.

NOTICE

Sterndrive, non-power assist cylinder part # HC5332 and HC5332-2 requires the use of SeaStar Outboard style HOSE. Do NOT use extruded nylon tubing with this cylinder.

Copper Tubing

SeaStar Solutions recommends the use of copper tubing where steering tube runs exceed 40 feet (see copper specifications below). Failure to install copper tubing in these applications may result in stiff/unresponsive steering. A series of copper tubing and flexible connections must be used, copper tubing CANNOT be connected directly to a steering cylinder. A flexible connection MUST be used.

Copper Tubing specifications

- 3/8" (OD).
- Seamless Copper Tube for Air Conditioning and Refrigeration made under ASTM B-280.
- Compression fittings shipped with steering cylinder(s) will work with the above specifications.

CAUTION

Never attach copper tubing or any other rigid type tube directly to the cylinder. Cylinders require a flexible link to allow for vibration and cylinder movement during steering articulation.

Positional O-Ring Horizontal and Vertical Tee Fitting Installation/Realignment (if required)

1. Back off lock nut (item 1, figure 24), counter-clockwise, until it stops.
2. Thread fitting into cylinder body until fitting washer (item 2, figure 24) contacts the face of the cylinder port. Tighten hand tight, DO NOT TORQUE FITTING INTO GLAND.
3. Position fitting to desired orientation by turning it counter-clockwise to a MAXIMUM of 1 full turn.
4. While holding fitting with a wrench, tighten the locknut (item 1, figure 24) and torque to 40–43 ft-lb.
5. Purge system as per your cylinder instruction manual.

CAUTION

DO NOT attempt to install NPT pipe fittings into the cylinder hose fitting ports on any -3 model cylinder. Doing so will lead to irreparable damage to the cylinder. ONLY use ORB hose fittings provided by SeaStar Solutions.

! WARNING

Failure to properly tighten the locknut (item 1, figure 24) may lead to loss of steering control. Loss of steering control may result in unpredictable boat behavior, collision with an obstacle and/or ejection from vessel, leading to property damage, personal injury and/or death.

! WARNING

SeaStar Solutions recommends that the hose and hose fittings are checked on a regular basis to ensure the safe operation of the steering system.

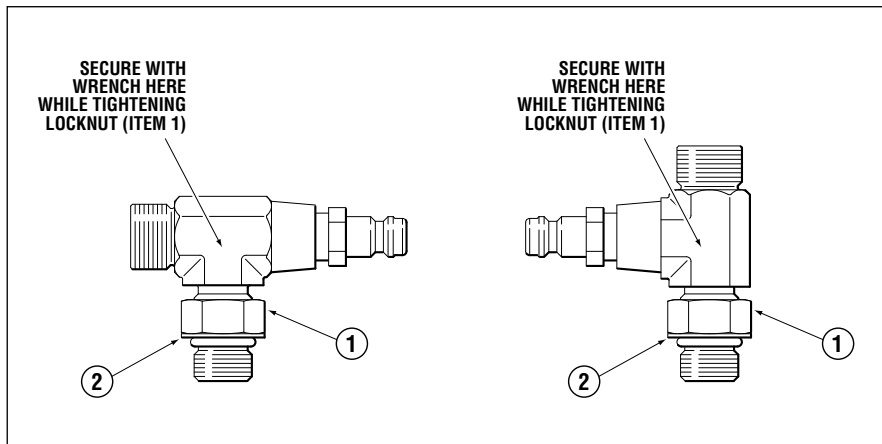

Figure 24.

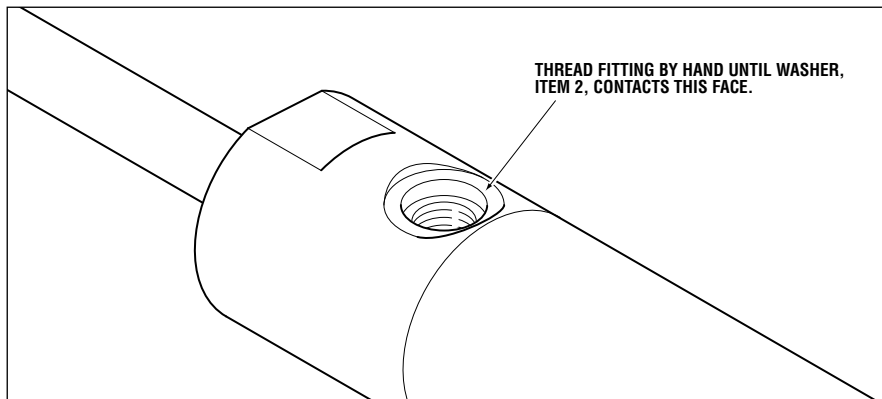

Figure 25.

System Connection

1. Refer to figure 26 on page 22 for hose/tube to fitting connection.
2. If not already completed, install fittings into helm as per specific instructions supplied with your helm pump.

! CAUTION

There is **NO** requirement for pipe sealant of any kind when using an ORB fittings. A "LIQUID" Teflon based pipe sealant **IS** required when using NPT type fittings. **DO NOT** use Teflon Tape or any other tape type sealers.

HYDRAULIC STEERING

HOSE & TUBE INSTALLATION

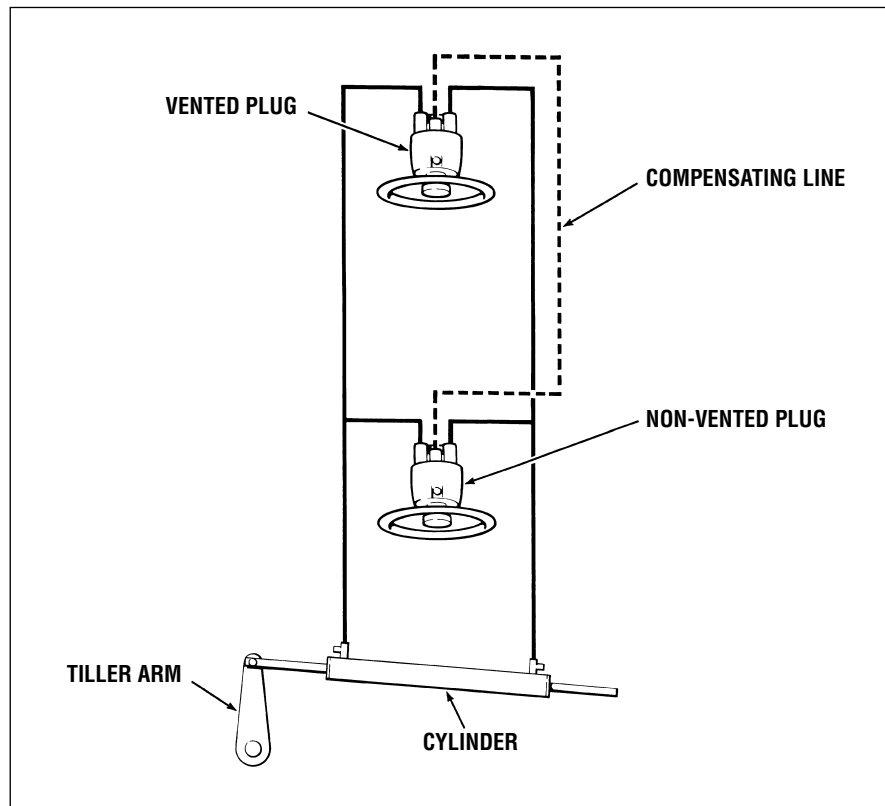

Figure 26. Dual Station.

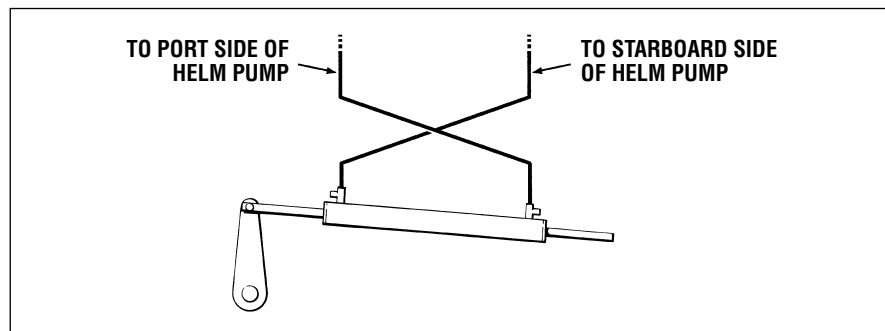

Figure 27. **HC5332-2 Cylinders ONLY.** Hoses are crossed when plumbing.

3. The following considerations **MUST** be taken into account when planning and routing steering hose/tubes.

- a) Cut nylon/copper tubing using an appropriate tube cutter. A straight and level cut is required for proper sealing.

⚠ CAUTION

DO NOT CUT SeaStar Outboard, flexible, hoses. Cutting these will render them useless and a new hose will need to be ordered.

- b) Do not allow hose/tube to come into contact or come too close to any source of extreme heat. Extreme heat **WILL** lower burst pressure and/or melt hose/tubing resulting in the immediate loss of steering control. Loss of steering control may lead to a collision with an obstacle and/or ejection from boat resulting in property damage, personal injury and/or death.

- c) Hose/Tube must be routed so that it will not interfere with any other functional equipment; (such as, hatches, doorways or in a walking path where it may become a tripping hazard).
- d) Hose/Tube MUST be installed with a gradual rise from the steering cylinder to the helm pump(s). If hose/tube is not installed with a gradual rise, air removal from system will be difficult.
- e) Hose/tube should be secured at regular intervals using non-metallic type ties.
- f) Do not allow tubing to rest or chafe against any abrasive material.

NOTICE

Fiberglass although soft to the touch can be extremely abrasive. Care MUST be taken when securing hose/tubing.

- g) Ensure that hose/tube ends are covered prior to passing through bulkheads, cable tubes and any other blind area. Failure to do so may allow contamination to enter the steering system.

! WARNING

If hose/tubing is kinked during and/or after installation it MUST be replaced prior to operation. SeaStar Outboard hose cannot be cut and must be replaced with a new hose completely. SeaStar extruded nylon tubing can have the damaged section removed and a union fitting put into place. Failure to replace any damaged hose/tube may result in loss of steering control. Loss of steering control may lead to unpredictable boat behavior and/or a collision with an obstacle and/or ejection from vessel, resulting in property damage, person injury and/or death.

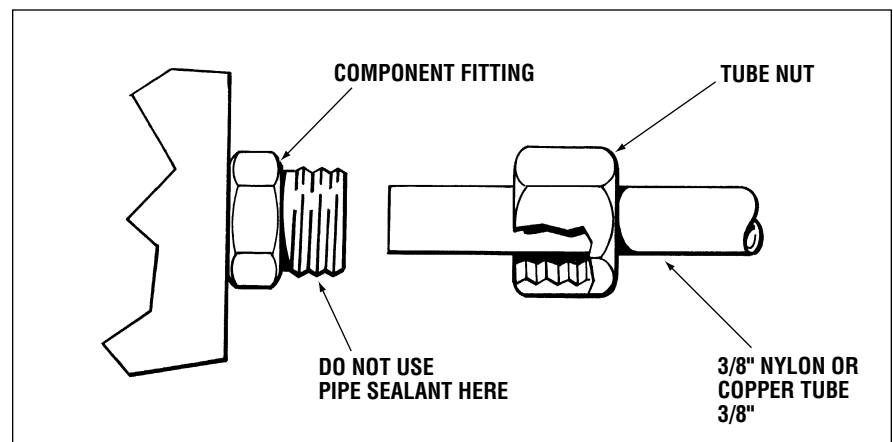

Figure 28.

4. Connection

- a) SeaStar Outboard Hose – While holding the fitting body securely with a wrench, torque the hose end nut to 15 ft-lbs.
- b) SeaStar extruded Nylon tubing and Copper Tubing.
 - Slide tube nut over tubing.
 - Push tubing into bottom of component fittings.
 - Hand tighten tube nut, ensuring that the tube is bottomed out against the fitting while tightening.
 - After hand-tight, turn an additional 1-1/2 turn with a 5/8" wrench.

! CAUTION

Ensure that the tubing is pushed ALL the way in.

ADDITIONAL STATIONS, AUTOPILOTS AND SEASTAR POWER ASSIST UNITS

General

ALL SeaStar helm pumps are fitted with internal check valves. These valves allow the installation of multiple steering stations and autopilots. ALWAYS check with autopilot manufacturers to confirm use with a SeaStar Steering System.

SeaStar offers the following “add a station fitting kits” for easy installation.

- **HF6007** For systems fitted with SeaStar **ORB helm pumps** plumbing with SeaStar Outboard, flexible, hoses ONLY. NOTE: this kit comes with a 25' cut to fit nylon tubing that is to be used for the return line ONLY. Another set of SeaStar Steering hoses, part # H051xx will be required to complete this installation.

NOTICE

SeaStar NPT helms use kit HF5501.

- **HF6010** For systems fitted with SeaStar **ORB helm pumps** plumbing with SeaStar Extruded Nylon tubing and/or copper tubing. Designed to splice into existing tubing.

NOTICE

SeaStar NPT helms use kit HF5502.

NOTICE

The following points should be taken into consideration when installing additional steering stations and/or autopilots. Following these simple points before installation will allow for easier trouble shooting in the future if required

- Shut-Off valves should be installed into each additional station. Installation of these now will allow for simplified trouble shooting and servicing at a later date.
- Autopilot must be compatible with SeaStar Steering Fluid, MUST have a pressure relief setting of 1000psi (6.9MPa) and MUST work with an unbalanced cylinder if equipped.
- A “return” or “compensating” line will be REQUIRED between all helms, autopilot pumps and SeaStar Power Assist Units. Failure to install this line will lead to improper bleeding, resulting in poor performance by both the steering system and autopilots.
- The “return” or “compensating” line MUST have a gradual rise between steering stations. If hose/tube is not installed with a gradual rise, air removal from system will be difficult.
- SeaStar Power Assist Units can be installed into an inboard type system. If installing a SeaStar Power Assist please be sure to read and understand the installation manual that will come with your SeaStar Power Assist.
- Helms of different displacements can be used in a multiple station system. Use of a higher or lower displacement will result in more/less wheel turns and easier/heavier effort at each wheel.

MANUAL FILLING AND PURGING

NOTICE

Power Purge Users. Please refer to the instructions included with your power purge unit.

Power Assist Users. You **MUST** refer to the bleeding instructions included with your SeaStar Power Assist Unit.

Liquid Tiebar Users (Catamarans). You **MUST** refer to the bleeding instructions included with your Liquid Alignment/Tiebar Valve.

Read First

Steps 1 – 5 noted on page 27 refer to a single station, single cylinder installation. For twin station and/or twin cylinder installations you **MUST** perform steps 1 – 5 first, then see page 28 and page 29 to complete the removal of air from the system.

NOTICE

This procedure requires two people. One person may not be able to remove all the air from the system which will result in spongy, unresponsive steering.

During the entire filling procedure, oil **must** be visible in the filler tube. **Do NOT** allow the oil level to disappear into the helm pump, as this may introduce air into the system and increase your filling time.

Hydraulic Fluid

SeaStar Solutions recommends the use of **SeaStar Steering Fluid ONLY**. SeaStar Steering Systems have been engineered and validated using our proprietary SeaStar Hydraulic Fluid.

⚠ WARNING

Any non-approved fluid may cause serious damage to the steering system resulting in possible loss of steering, causing property damage, personal injury and/or death.

Emergency Use Fluids

In an emergency, SeaStar EPS Fluid, any MD-3/4 rated ATF or MIL-PRF-5606H equivalent fluid that is filtered through a fine mesh screen can be used. The system **MUST** be thoroughly flushed as soon as possible with genuine SeaStar Steering Fluid after using an emergency fluid. **In an EXTREME emergency, any non-toxic, non-flammable fluid that is filtered through a fine mesh screen may provide temporary steering.**

⚠ WARNING

Never fill or mix brake fluids, triglycerides or polyalkylene glycols within a hydraulic steering system.

Vent Plug
Part # HP6126 (5 per kit)

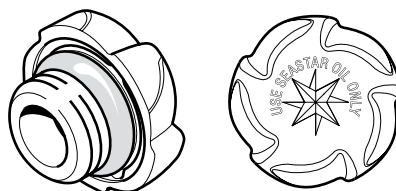

- Must be used with helm pump on all single steering station systems.
- Must be used on upper-most helm pump only on multi-steering station systems.
- Vent hole: actual size as shown.
- Colour: threads silver – cap black.

Figure 29.

HYDRAULIC STEERING

FILLING AND PURGING

Non-Vent Plug

Part # HP6000 (5 per kit)

⚠ CAUTION

Failure to install a non-vent plug in ALL lower helms of multi-helm systems will result in fluid leaking out of the vent cap.

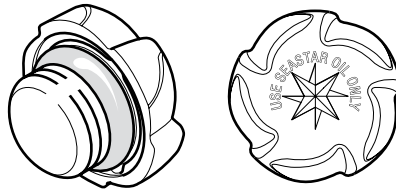

- Must be used on all helm pumps other than upper-most helm pump on multi-steering station systems.
- This non-vent plug is supplied with additional station fitting kit no. HF6007 and HF6010.
- Actual size shown.
- Colour: threads silver – cap gray.

Figure 30.

Hydraulic Oil Requirements

Single station, single cylinder applications will generally require two bottles (one quart per bottle) of fluid. Another bottle will be required for each additional device in the system (helm, cylinder, power assist, or auto pilot).

During the purging process hydraulic fluid will be flushed out of the system. The fluid may be re-used if filtered through a fine mesh filter, such as those designed for filtering gasoline. If you are unable to filter the steering fluid, you will require an additional bottle.

NOTICE

“Bleeder” refers to the machined bleed fitting at each end of the steering cylinder. Open bleeder by turning counterclockwise two turns.

NOTICE

Filling the helm full of oil can be done faster if oil is poured into the helm prior to connecting filler tube and oil bottle to the helm.

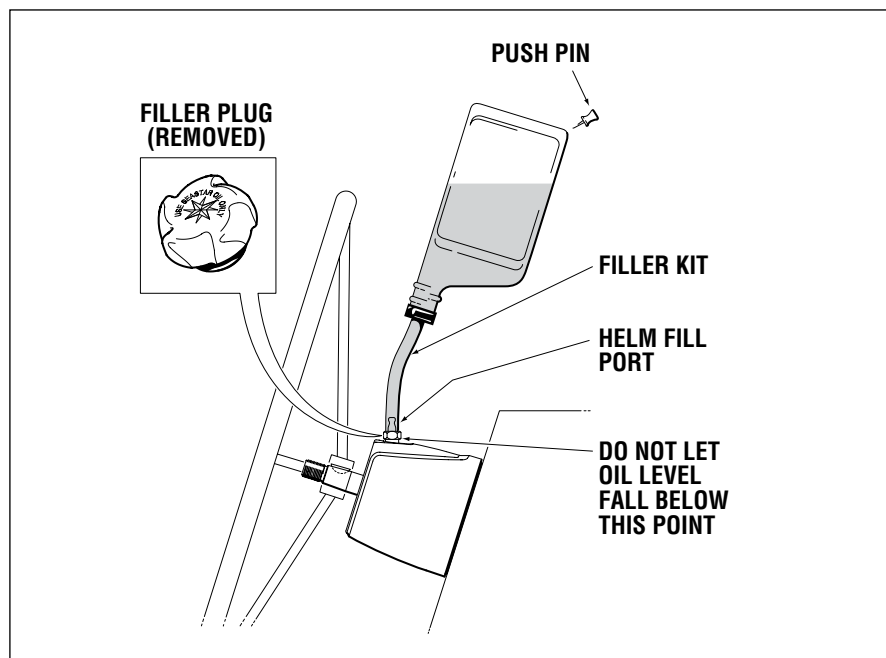

Figure 31.

Single Station One Cylinder

HYDRAULIC STEERING

FILLING AND PURGING

Step 1

- Screw the threaded end of the filler tube into the helm filler hole.
- Remove the cap from the oil bottle and holding upright, screw into the filler tube bottle cap. Poke hole in the bottom of the bottle.
- Fill the helm pump full of oil (Oil should always be visible in the filler tube). Use the next bottle at any time throughout the procedure when the oil level drops in the filler tube. Do not proceed with step two until helm is full of oil.

Figure 32.

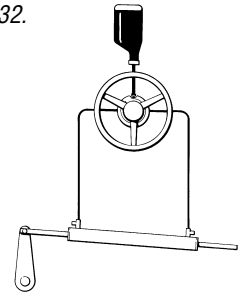

Step 2

- Turn the steering wheel clockwise until the cylinder rod is fully extended on the Port side of the cylinder.
- Open Port side bleeder.

Figure 33.

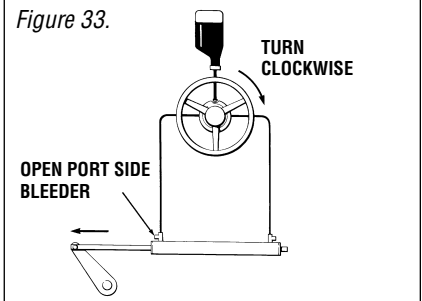

Step 3

- Holding the cylinder rod (to prevent it from moving back into the cylinder) turn the steering wheel counter-clockwise until a steady stream of air free oil comes out of the bleeder. (Drain out approx. 1/2 bottle of oil or as required.)
- While continuing to turn the wheel, close the Port side bleeder and let go of the cylinder rod.

Figure 34.

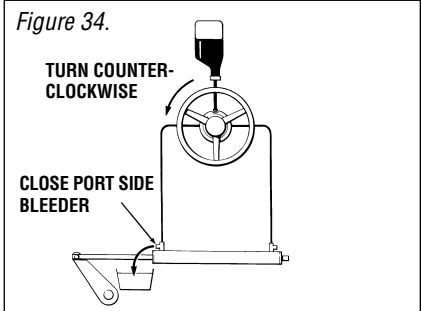

Step 4

- Continue turning the steering wheel counter-clockwise until the cylinder rod is fully extended to Starboard. (Steering wheel will come to a stop.)
- Open the Starboard bleeder.

Figure 35.

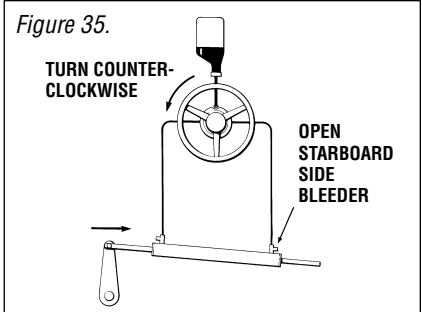

Step 5

- Holding the cylinder rod (to prevent it from moving back into the cylinder) turn the steering wheel clockwise until a steady stream of air free oil comes out of bleeder.
- While continuing to turn the wheel, close the Starboard side bleeder and let go of the cylinder rod.

Figure 36.

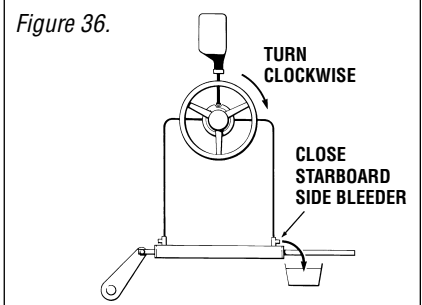

Fill and purge is now complete.

HYDRAULIC STEERING

FILLING AND PURGING

Oil Level Set

- Proper oil level set can be obtained by opening Starboard bleeder and turning steering wheel to Starboard until fluid level reaches top of plastic filler fitting and then turning wheel one more full turn.

⚠ CAUTION

For unbalanced cylinders the oil level in the helm must be set with the cylinder rod fully retracted. Failing to observe this caution will result in an oil spill at the helm.

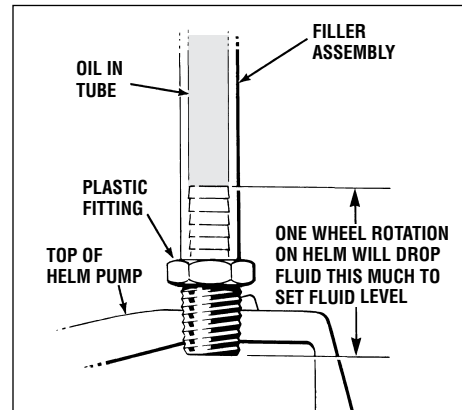

Figure 37.

Twin Station Single Cylinder

- Perform steps 1 through 5 at station no. 1. Then repeat steps 1 – 5 at station no. 2.
- Oil requirement: 4 – 5 bottles.

NOTICE Refer to Oil Level and System Proof Check on page 30.

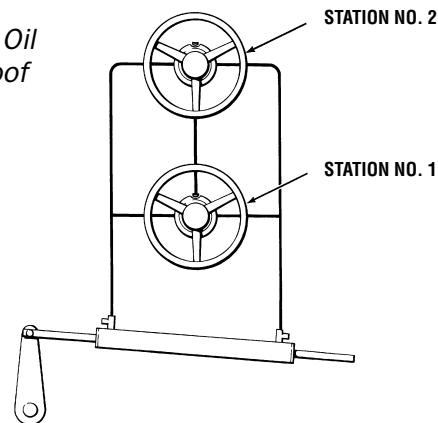

Figure 38.

Single Station Twin Cylinder

- When performing steps 1 through 5, perform instructions in each step first on cylinder no. 1 and then on cylinder no. 2, before proceeding to the next step. ie: Perform instructions referring to Starboard side of cylinder first on cylinder no. 1 and then on cylinder no. 2.
- Oil requirement: 4 – 5 bottles.

NOTICE Refer to Oil Level and System Proof Check on page 30.

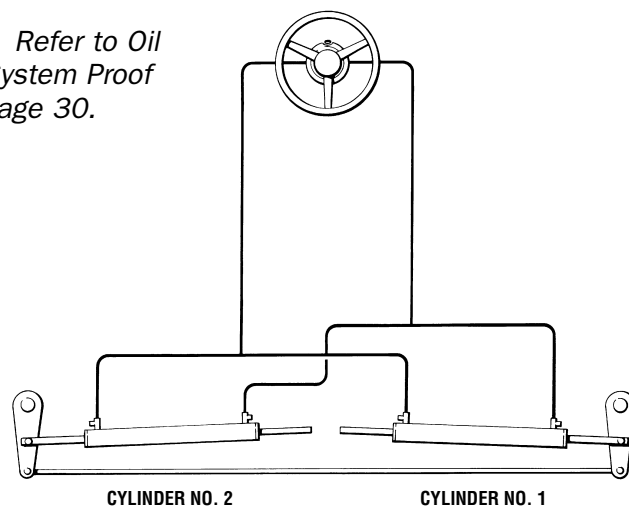

Figure 39.

Twin Station Twin Cylinder

- Follow same procedure as instructed for single-station/
twin-cylinders, beginning at station no. 1, and repeat entire
procedure at station no. 2.
- Oil requirement: 5 – 6 bottles.

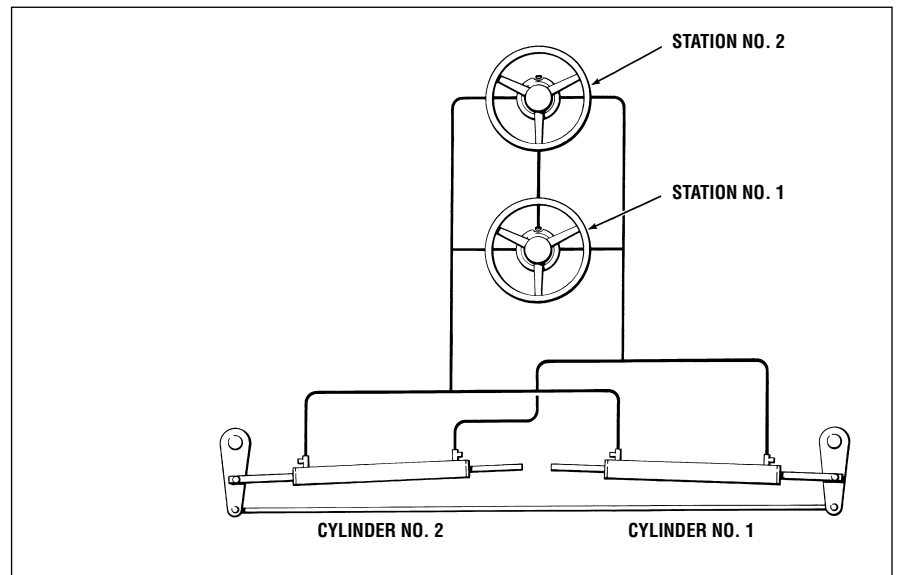

Figure 40.

OIL LEVEL AND SYSTEM PROOF CHECK

STEP 1

Oil Level Setting

WARNING

The oil level **MUST** be checked and maintained **BEFORE** each use to ensure the safe operation of your steering system. Failure to adhere to this warning may lead to loss of steering control. Loss of steering control may result in unpredictable boat behavior, collision with an obstacle and/or ejection from vessel, leading to property damage personal injury and/or death.

CAUTION

When setting fluid level in a system fitted with an unbalanced cylinder, the cylinder shaft **MUST** be fully retracted (IN). Failure to have cylinder shaft retracted (IN) will lead to very stiff steering and/or oil spillage at the helm pump.

- Helms mounted with the wheel shaft completely horizontal **MUST** be filled to the bottom of the filler hole **AT ALL TIMES**.
DO NOT allow oil level to drop more than 1/4" below the filler port threads.
- For helms mounted on a 20° angle, or, with wheel shaft in the vertical position the oil level must be no lower than 1/2" below filler port threads and no higher than 1/8" below filler port threads.

STEP 2

System Proof Check

WARNING

The System Proof Check **MUST** be completed after installation. Doing so will ensure the safe operation of your steering system. Any fault (leaks or malfunction) will present itself during this check. Failure to adhere to this check may result in loss of steering control. Loss of steering control may lead to unpredictable boat behavior, leading to a collision with an obstacle and/or ejection from the boat, resulting in property damage personal injury and/or death.

- Turn steering wheel hard over to hard over to confirm unrestricted movement of steering components.

NOTICE

If equipped with a tilting helm, repeat this step in every tilt position.

- Confirm that rudder(s) and outdrive(s) are turning to the proper direction.
- If no interference is noticed and rudder(s) and/or outdrive(s) are turning to the proper direction, go to next point
- Take steering wheel hard over to starboard. Once the wheel reaches its stop point, force the wheel another 1/4 – 1/2 turn past stop. Leave wheel in this position while you inspect ALL fittings, helms and hose/tubes for any signs of a leak.
- Repeat above step to the starboard side of each steering station
- Repeat above steps to the port side of each steering station.
- If ANY leaks are noticed they **MUST** be repaired **BEFORE** operating your boat.

WARNING

Failure to correct **ANY** problem that becomes present during the 'System Proof Check' may lead to loss of steering control. Loss of steering control can lead to unpredictable boat behavior and/or collision with obstacle and/or ejection from vessel resulting in property and/or personal injury or death.

⚠ WARNING

ROUTINE MAINTENANCE

Following the routine maintenance schedules as outlined below, in the time frame noted will ensure years of service from your SeaStar Steering System, as well as keep you and your passengers safe from the dangers that are present on and off the water.

1. Owner(s) (End Users)

Prior to every use.

1. Check fluid level in highest helm pump (see page 30) for proper fluid level setting).
2. Verify immediate steering response when turning steering wheel(s). (Ensure drive(s)/rudder(s) move when steering wheel(s) are turned.)
3. Visually inspect all steering hoses and fittings for wear, kinking and/or leaks.
4. Check for binding, loose, worn or leaking steering components.

⚠ WARNING

DO NOT operate boat if any component is not in proper working condition.

2. Qualified Marine Mechanic

After first 20 hours, then every 100 hours or 6 months thereafter (which ever comes first).

- All points noted above.
- Check tightness of ALL fasteners throughout the steering system. Tighten as required.
- Check for mechanical play or slop throughout steering system, correct as required.

⚠ WARNING

Any work being performed with the steering system MUST be completed by a qualified mechanic with the working knowledge of the system.

After every 200 hours or 12 months (which ever comes first).

- All points noted above.
- Power Assisted Drives:
 - Remove cylinder from power assist steering tube. Clean steering tube and re-grease using a good quality marine grease.
- Inboard:
 - Grease ball joint (rudder connection) using a good quality marine grease.
 - Ensure rudder(s) are able to be moved freely by hand.
- Remove steering wheel and re-grease wheel shaft using a good quality marine grease.
- Inspect hydraulic oil for cleanliness, flush if required.

TROUBLESHOOTING GUIDE

SeaStar hydraulic steering will provide years of safe reliable performance with a minimum of service if properly installed with correct cylinder.

SeaStar steering systems have been designed with protection against over-pressure situations, by a pressure relief valve, to minimize the possibility of total loss of steering.

Most faults occur when the installation instructions are not followed and usually show up immediately upon filling the system. Provided below, are the most common faults encountered and their likely cause and solution. The term “Rudder” also applies to stern drives, when applicable.

Sometimes when returning the wheel from a hardover position, a slight resistance may be felt and a clicking noise may be heard. This should not be mistaken as a fault, as it is a completely normal situation caused by the releasing of the lockspool in the system.

WARNING

Whenever in the following text, a solution calls for removal from vessel and/or dismantling of steering system components, such work must only be carried out by a qualified marine hydraulic mechanic. SeaStar Solutions offers the following as a guide only and is not responsible for any consequences resulting from incorrect dismantling repairs.

FAULT

1. During Filling, the helm becomes completely jammed.

CAUSE

- Blockage in the line between the helm(s) and the cylinder(s).

SOLUTION

- Make certain that tubing has not collapsed during installation. If so, the collapsed section must be removed and re-fitted with a new piece with the aid of tube connectors. Check fittings for incomplete holes. Fittings with incomplete holes, however, are not common.

2. System is very difficult to fill. Air keeps burping out top of helm even after system appears full.

- Cylinder(s) has been mounted upside down. This causes air to be trapped in the cylinder(s).
- Air in system.

- Mount cylinder(s) correctly, according to cylinder installation instruction. Ports should always be kept in uppermost position.
- Review filling instructions.

FAULT

3. Steering is stiff and hard to turn, even when the vessel is not moving.

CAUSE

- Rudder post glands are too tight or rudder post is bent, causing mechanical binding. The same applies to tiller arm and linkage on outdrives.
- Restrictions in hose, copper tubing, piping or fittings.
- Wrong oil has been used to fill steering system, like A.T.F. (automatic transmission fluid, or any other oil with a high viscosity factor).
- Support tubex corroded or seized restricting movement of hydraulic cylinder.

SOLUTION

- To test, disconnect cylinder(s) from the tiller arm and turn the steering wheel. If it turns easily, correct above mentioned problems. Please note that excessively loose connections to tiller arm or tie-bar can also cause mechanical binding.
- Find restriction and correct. **Note:** Collapsing of copper tubing during bending is enough to cause restrictions.
- Drain system and fill with SeaStar Steering Fluid.
- Remove cylinder, clean and re-grease.

4. One helm unit in system is very bumpy and requires too many turns from hardover to hardover.

- Dirt in inlet check of helm pump.

- Contact Authorized repair center and/or replace helm pump.

5. Steering is easy to turn at the dock, but becomes hard to turn when vessel is underway.

- Steering wheel is too small.
- Cylinder(s) too small.
- Incorrect setting of trim tab(s) on stern drive.
- Incorrectly designed or adjusted rudders, causing binding on rudder post and/ or tie bar at cruising speeds.

- Fit larger wheel if possible, see installation instructions. If the problem cannot be rectified by the above mentioned solution, proceed with next cause and solution or consult factory.
- Replace with larger cylinder(s).
- Adjust tab(s).
- Seek professional help. Have competent, qualified marine mechanic correct problem.
- Fit system with SeaStar Power Assist. **NOTE:** *SeaStar Power Assist is not intended to compensate for a weak, or improperly installed steering cylinder.*

HYDRAULIC STEERING

TROUBLESHOOTING

FAULT

6. Rudder drifts to port or starboard while vessel is underway, even when wheel is not being turned.

CAUSE

- Dirt in check valves.

SOLUTION

- Contact authorized repair center and/or replace helm pump.

7. Turning one wheel causes the second steering wheel to rotate.

- See fault No. 6.

- See fault No. 6.

8. Consistent wearing of rod end ball and or mounting foot.

- Excess vibration at rudder.

- Consult with boat builder and/or Naval architect for vibration cure.

9. Sterndrive system is hard to turn with engine off.

- Engine driven power steering pump not operating.

- This is normal in a power steering application.

TECHNICAL INFORMATION

Bolt Torque Specifications

These are the recommended maximum torque values for reusable dry bolts. Bolts should be torqued to this value +0% -20%. For lubricated bolts, multiply the dry bolt torque values by .75.

Values are stated in: **in-lbs (Nm)**

Bolt Size	18-8SS	Brass	Bolt Size	18-8SS	Brass	Bolt Size	18-8SS	Brass
2-56	2.5 (.282)	2.0 (.226)	6-32	9.6 (1.08)	4.9 (.554)	5/16"-18	132.0 (14.91)	107.0 (12.10)
2-64	3.0 (.338)	2.5 (.282)	6-40	12.0 (1.35)	9.9 (1.12)	5/16"-24	142.0 (16.04)	116.0 (13.11)
3-48	3.9 (.440)	3.2 (.361)	8-32	20.0 (2.25)	16.0 (1.81)	3/8"-16	236.0 (26.66)	192.0 (21.71)
3-56	4.4 (.497)	3.6 (.407)	8-36	22.0 (2.48)	18.0 (2.03)	3/8"-24	259.0 (29.20)	212.0 (23.97)
4-40	5.2 (.587)	4.3 (.486)	10-24	23.0 (2.59)	19.0 (2.14)			
4-48	6.6 (.740)	5.4 (.610)	10-32	32.0 (3.61)	26.0 (2.94)			
5-40	7.7 (.869)	6.3 (.712)	1/4"-20	75.0 (8.47)	62.0 (7.01)			
5-44	9.4 (1.06)	7.7 (.869)	1/4"-28	94.0 (10.6)	77.0 (8.70)			

Values are stated in: **ft-lbs (Nm)**

Bolt Size	18-8SS	Brass	Bolt Size	18-8SS	Brass	Bolt Size	18-8SS	Brass
7/16"-14	31.0 (42.00)	26.0 (35.25)	5/8"-11	93.0 (126.09)	76.0 (103.04)	1"-8	287.0 (389.12)	235.0 (318.62)
7/16"-20	33.0 (44.74)	27.0 (36.61)	5/8"-18	104.0 (141.00)	85.0 (115.24)	1"-14	259.0 (351.16)	212.0 (287.43)
1/2"-13	43.0 (58.30)	35.0 (47.45)	3/4"-10	128.0 (173.55)	104.0 (141.00)			
1/2"-20	45.0 (61.01)	37.0 (50.17)	3/4"-16	124.0 (168.12)	102.0 (138.29)			
9/16"-12	57.0 (77.28)	47.0 (63.72)	7/8"-9	194.0 (236.03)	159.0 (215.58)			
9/16"-18	63.0 (85.42)	51.0 (69.15)	7/8"-14	193.0 (261.67)	158.0 (214.22)			

Fittings

SeaStar cylinder and all other fittings are 3/8" compression type fittings. Threads are 9/16" x 24 extra fine. A brochure on all SeaStar fittings is available from SeaStar.

SeaStar and SeaStar PRO

- SeaStar and SeaStar PRO hose inside diameter – 5/16" (8 mm).
- SeaStar Hose, 1000psi WP
- SeaStar PRO Hose, 1500psi WP

PARTS LIST

Brass Ball Mount Cylinders

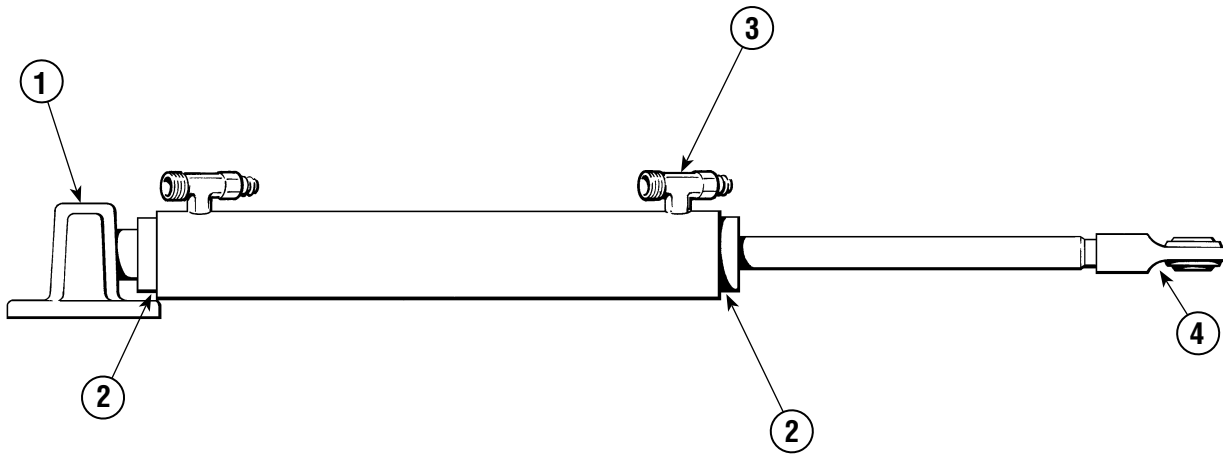

NOTICE

SeaStar Solutions does not sell internal parts. Contact Authorized repair center for repair and/or replace cylinder.

⚠ WARNING

When replacing any seals, make sure shaft is clear of any abrasions.

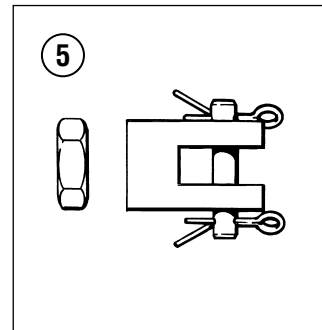

Figure 41.

CYLINDER	Item 1 Ball Mount Assy.	Item 2 Seal Kit*	Item 3 Fitting Kit**	Item 4 Rod End Kit	Item 5 Clevis Connection Kit
HC5318 / HC5318CAT	HP6068	HS5182	HF5518	HP6093	HP6024
HC5369					
HC5319 / HC5319CAT		HS5183		HP6013	HP5615
HC5373					

* Kit includes seals for both glands. Does not contain piston seals.

** Kit contains two fittings, with bleeders.

Aluminum Ball Mount Cylinders

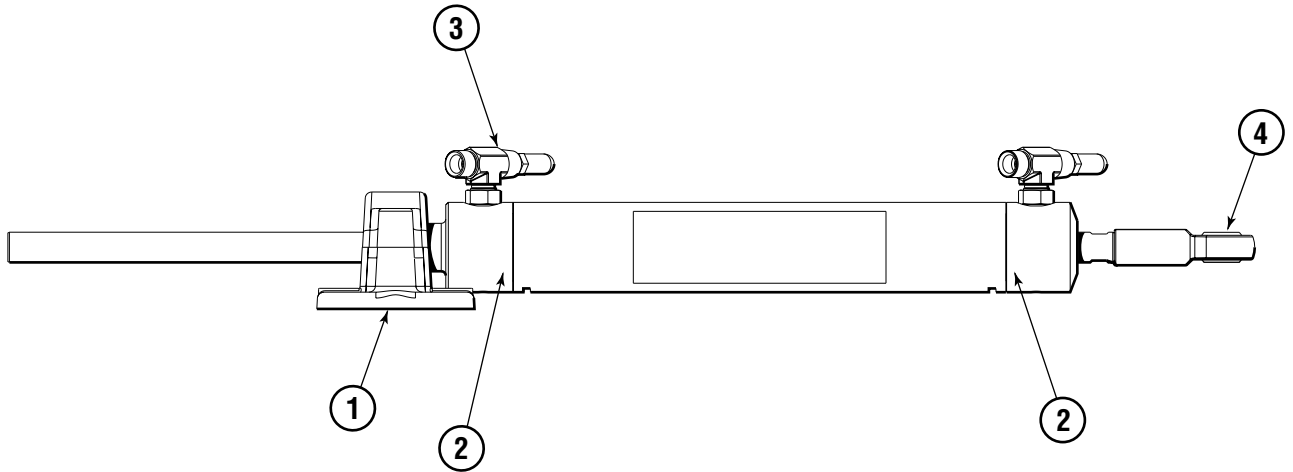

NOTICE

SeaStar Solutions does not sell internal parts. Contact Authorized repair center for repair and/or replace cylinder.

WARNING

When replacing any seals, make sure shaft is clear of any abrasions.

Figure 42.

CYLINDER	Item 1 Ball Mount Assy.	Item 2 Seal Kit*	Item 3 Fitting Kit**	Item 4 Rod End Kit
HC5303-3	HP5611	HP6026	HF6002 (Horizontal)***	HP6079
HC5312-3				HP6077
HC5313-3		HP6025		HP6077
HC5314-3	HP6080	HP6071	HF6003 (SAE Flare)	HP6013
HC5319-3				
HC5373-3				

* Kit includes seals for both glands. Does not contain piston seals.

** Kit contains two fittings, with bleeders.

*** Cylinder ships with horizontal fittings as standard.

HYDRAULIC STEERING

PARTS LIST

HC5322-3 and HC5323-3

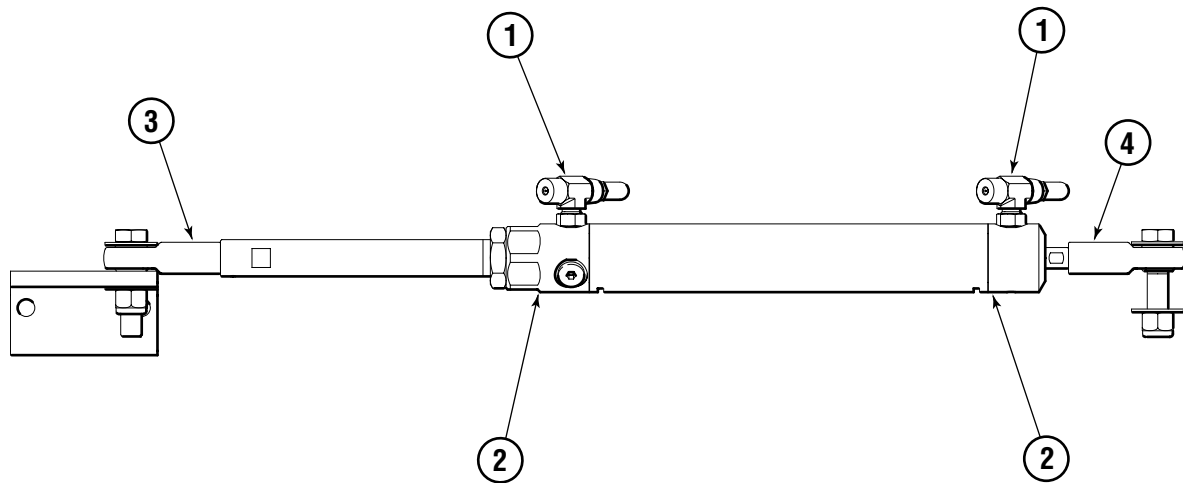
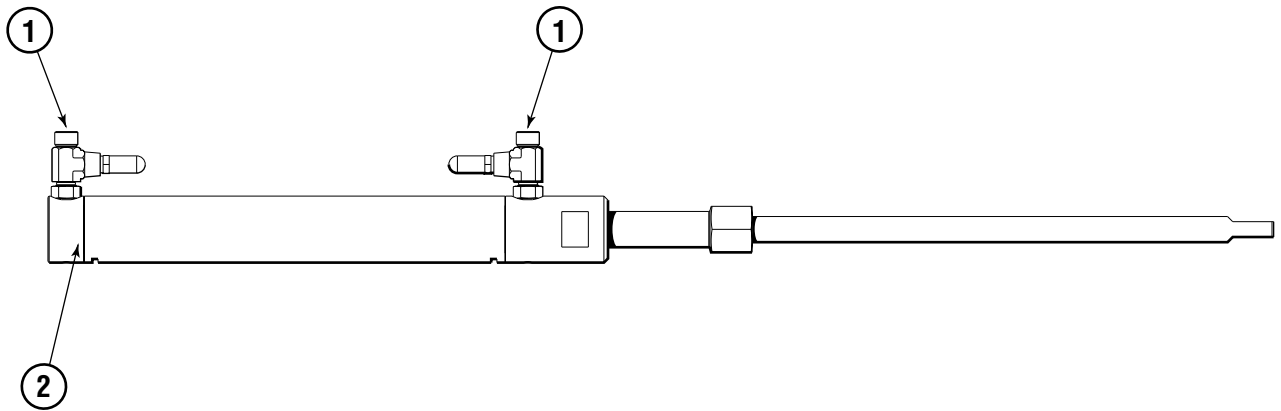

Figure 43.

ITEM	PART #	QTY	DESCRIPTION
1	HF6001	1	Bleeder/Tee Assembly, Horizontal (2 per kit)
	HF6002	1	Bleeder/Tee Assembly, Vertical (2 per kit)
	HF6003	1	Bleeder/Tee Assembly, Hydraulic (2 per kit)
2	HP6023	1	Side Mount Gland Kit
3	HP6077	1	Rod End Ball 1/2", 1/2-20
4	HP6137	1	Rod End Ball 1/2", 7/16-20

ITEM	PART #	QTY	DESCRIPTION

HC5328-3, HC5329-3 and HC5330-3



NOTICE

SeaStar Solutions does not sell internal parts. Contact Authorized repair center for repair and/or replace cylinder.

⚠ WARNING

When replacing any seals, make sure shaft is clear of any abrasions.

Figure 44.

ITEM	PART #	QTY	DESCRIPTION
1	HF6001	1	Bleeder/Tee Assembly, Horizontal <i>(2 per kit)</i>
	HF6002	1	Bleeder/Tee Assembly, Vertical <i>(2 per kit)</i>
2	HP6027	1	End Gland Seal Kit

ITEM	PART #	QTY	DESCRIPTION

HYDRAULIC STEERING

PARTS LIST

HC5326-3

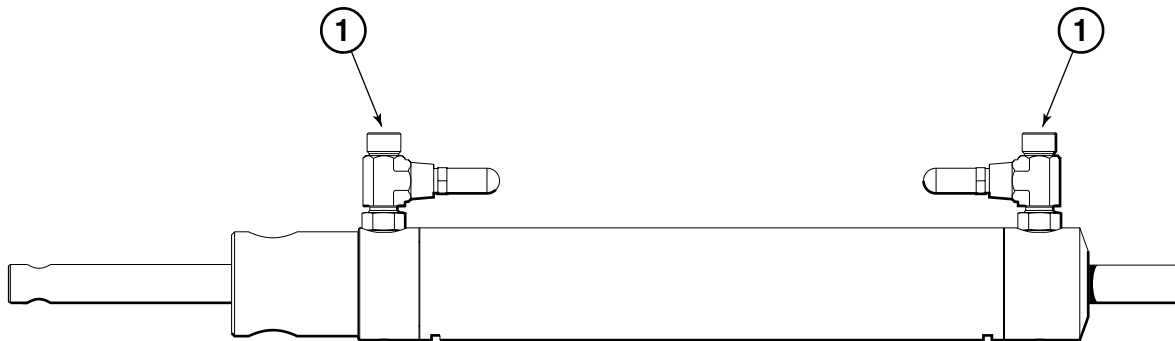

NOTICE

SeaStar Solutions does not sell internal parts. Contact Authorized repair center for repair and/or replace cylinder.

WARNING

When replacing any seals, make sure shaft is clear of any abrasions.

Figure 45.

ITEM	PART #	QTY	DESCRIPTION
1	HF6001	1	Bleeder/Tee Assembly, Horizontal (2 per kit)
	HF6002	1	Bleeder/Tee Assembly, Vertical (2 per kit)

ITEM	PART #	QTY	DESCRIPTION
------	--------	-----	-------------

HYDRAULIC STEERING

PARTS LIST

HC5331-3

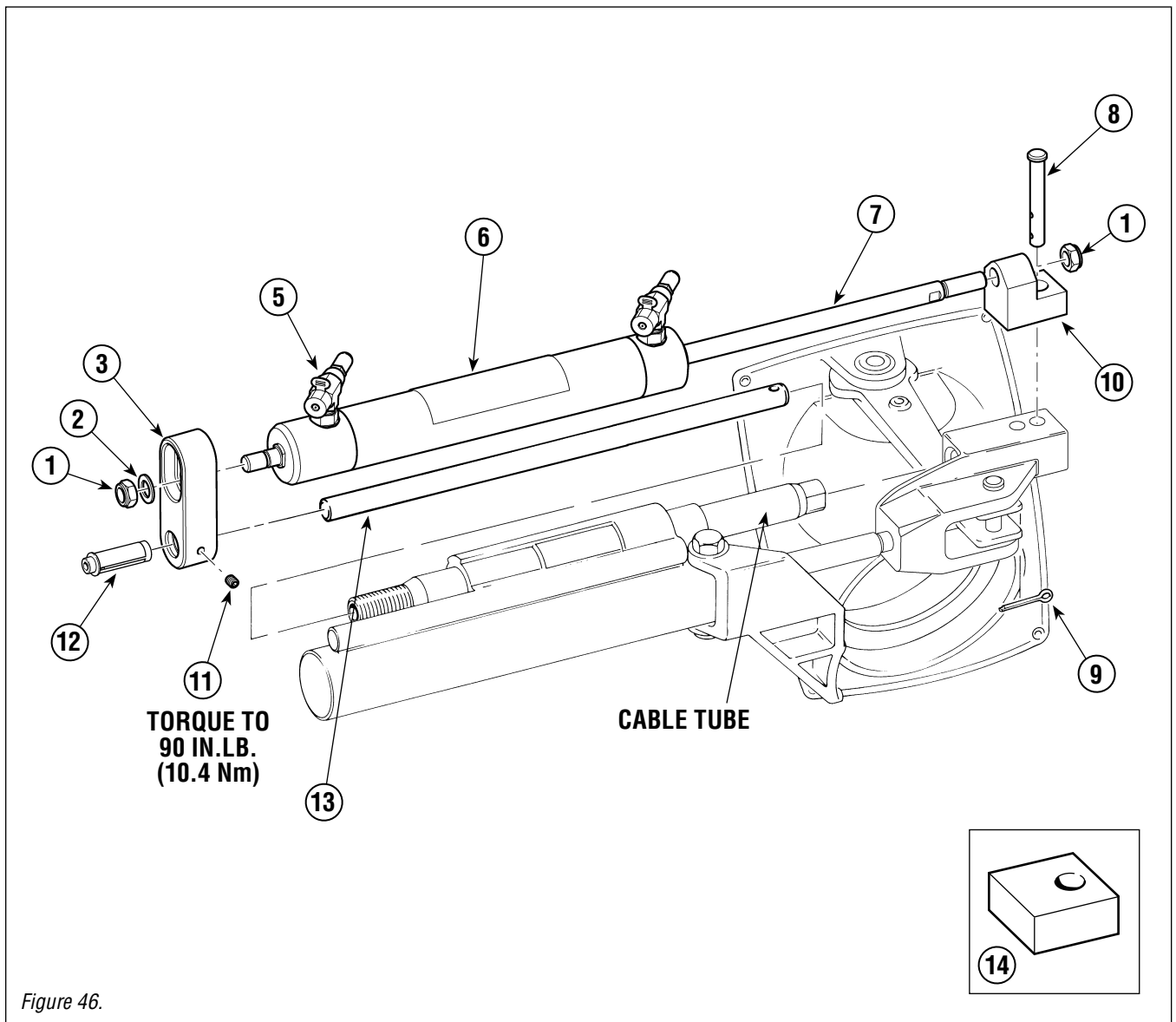

Figure 46.

ITEM	PART #	QTY	DESCRIPTION
*1	731720	2	Nut 7/16" NF
*2	731625	1	Washer 7/16"
*3	343051	1	Support Bracket
*4	343057	1	Mounting Stud
5	HF6002	2	Hose/Bleed Fitting (2 per kit)
*6	343608	1	Barrel
*7	343424	1	Piston Shaft

ITEM	PART #	QTY	DESCRIPTION
*8	562923	1	Clevis Pin
*9	020926	1	Cotter Pin
*10	343052	1	Clevis Block
*11	790625	1	Set Screw, 1/4"
12	HP6092	1	Tube Support
*13	321446	1	Support Rod
*14	963721	1	Clevis Block

*Replacement parts cannot be ordered by individual part number. Contact an authorized repair center.

HYDRAULIC STEERING

PARTS LIST

HC5386-3

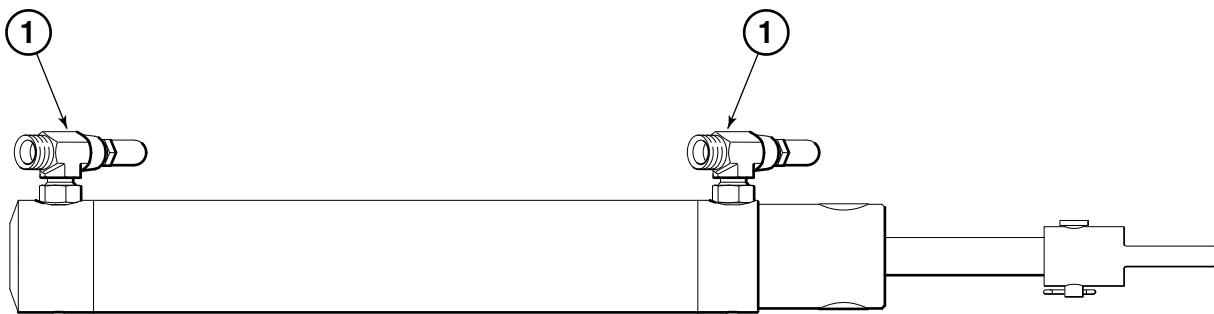

NOTICE

SeaStar Solutions does not sell internal parts. Contact Authorized repair center for repair and/or replace cylinder.

⚠ WARNING

When replacing any seals, make sure shaft is clear of any abrasions.

Figure 47.

ITEM	PART #	QTY	DESCRIPTION
1	HF6001	1	Bleeder/Tee Assembly, Horizontal (2 per kit)
	HF6002	1	Bleeder/Tee Assembly, Vertical (2 per kit)
2	HP6086	1	Seal Kit (Not Shown)

ITEM	PART #	QTY	DESCRIPTION
------	--------	-----	-------------

WARRANTY

Statement of Limited Warranty

We warrant to the original retail purchaser that **Marine Canada Acquisition Inc. DBA SEASTAR SOLUTIONS** (herein forward referred to as SeaStar Solutions) products have been manufactured free from defects in materials and workmanship. This warranty is effective for two years from date of purchase, excepting that where **SeaStar Solutions** products are used commercially or in any rental or income producing activity, then this warranty is limited to one year from the date of purchase.

We will provide replacement product without charge, for any **SeaStar Solutions** product meeting this warranty, which is returned (freight prepaid) within the warranty period to the dealer from whom such product were purchased, or to us at the appropriate address. In such a case **SeaStar Solutions** products found to be defective and covered by this warranty, will be replaced at **SeaStar Solutions'** option, and returned to the customer.

The above quoted statement is an extract from the complete **SeaStar Solutions** products warranty statement. A complete warranty policy is available in our **SeaStar Solutions** products catalogue.

For more information please visit our website:

www.seastarsolutions.com/support-2/warranty-2/seastar-solutions-warranty

Return Goods Procedure

Prior to returning product to **SeaStar Solutions** under warranty, please call: **604-248-3858** or email: **Marine.Warranty@seastarsolutions.com** to obtain a return goods authorization number (claim number) and further shipping instructions.

Technical Support

Phone: 604-248-3858

email: seastar@seastarsolutions.com

Hours: Monday to Friday 05:00 – 15:30 PST

Web: www.seastarsolutions.com

Authorized Service Centers & Distributors

For a current listing of all our authorized service centers and distributors please visit our website: www.seastarsolutions.com

© 2006 MARINE CANADA ACQUISITION INC.
DBA SEASTAR SOLUTIONS

PRINTED IN CANADA 02/20

Please scan
this QR code
and watch our
latest **Boating
Safety** video.



**SEASTAR
SOLUTIONS®**

SEASTAR SOLUTIONS
3831 NO. 6 ROAD
RICHMOND, B.C.
CANADA V6V 1P6

www.seastarsolutions.com

ISO 10592



FORM NO. 343319 REV. P

