



TALON

▼ SHALLOW WATER ANCHOR ▼

Owner's Manual

INTRODUCTION

THANK YOU

Thank you for purchasing the Minn Kota® Talon shallow water anchor. This revolutionary shallow water anchor uses state-of-the-art patented technology to deliver unprecedented levels of boat control. Intuitive features and wireless control enable Talon to accurately position your boat and improve your bait presentation. Talon holds your boat in position so you can focus on fishing.

REGISTRATION

Remember to keep your receipt and immediately register your Talon. To receive all the benefits of your product warranty please fill out and mail the registration card. You may also register your product online at minnkotamotors.com.

SERIAL NUMBER

Your Minn Kota 11-character serial number is very important. It helps to determine the specific model and year of manufacture. When contacting Consumer Service or registering your product, you will need to know your product's serial number. We recommend that you write the serial number down so that you have it available for future reference.



NOTICE: The serial number on your Talon is located below the motor housing.

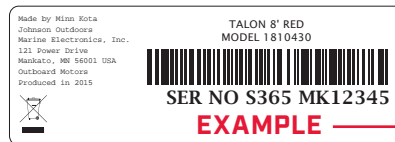

TALON INFORMATION (For Consumer Reference Only)

Model: _____

Serial Number: _____

Purchase Date: _____

Store Where Purchased: _____

NOTICE: Do not return your Minn Kota product to your retailer. Your retailer is not authorized to repair or replace this unit. You may obtain service by: calling Minn Kota at (800) 227-6433; returning your Talon to the Minn Kota Factory Service Center; sending or taking your product to any Minn Kota authorized service center. A list of authorized service centers is available on our website, at minnkotamotors.com. Please include proof of purchase, serial number and purchase date for warranty service with any of the above options.

TABLE OF CONTENTS

SAFETY CONSIDERATIONS	4
WARRANTY	5
KNOW YOUR BOAT	6
FEATURES	7
INSTALLATION	8
Installing the Talon	8
Installing the Water Deflection Shield.....	15
Installing the Power Cable and Deployment Notification Alarm Wire.....	17
Verifying Installation	20
BATTERY & WIRING INSTALLATION	21
Boat Rigging & Product Installation	21
Conductor Gauge and Circuit Breaker Sizing Table	21
Selecting the Correct Batteries	22
Connecting the Batteries.....	22
WIRING DIAGRAM	24
USING THE TALON	25
Talon Features.....	25
Depth Indication LEDs.....	26
Mode Functions	27
Controlling the Talon with the Indicator Panel	28
Controlling the Talon with the Remote	33
SERVICE & MAINTENANCE	38
Replacing the Remote Battery	38
Pairing A Remote to a Single Talon	40
Pairing Two Talons and Programming the Mounting Location.....	41
Pairing A Remote To Two Talons.....	42
Clearing Paired Remotes or Devices from the Talon	42
Clearing Paired Talons from the Remote	43
Manually Retract the Talon.....	43
The Retraction Notification Alarm	44
Reset the Fuse	45
Replacing the Spike	45
General Maintenance.....	49
Troubleshooting.....	50
For Further Troubleshooting And Repair.....	51
COMPLIANCE STATEMENTS	52
PARTS DIAGRAM & PARTS LIST	54

SAFETY CONSIDERATIONS

Please thoroughly read the user manual. Follow all instructions and heed all safety considerations. Use of this product is only permitted for persons that have read and understood these instructions. Minors may use this product only under adult supervision.

WARNING

You are responsible for the safe and prudent operation of your boat or vessel, and Talon(s). This product does not relieve you from the responsibility of safe operation of your boat. It may be hazardous to operate your Talon in rough or turbulent water conditions, such as fast currents or changing environmental conditions. Do not deploy your Talon if these conditions are present, especially when the underwater topography is unknown. Failure to follow this warning may result in unexpected operation or failure of the Talon to operate or anchor and could cause death or serious injury. You must avoid hazards to anchoring and always maintain a permanent watch so you can maintain proper control of your boat. You must always be prepared to regain manual control of your boat. Learn to operate your Minn Kota product in an area free from hazards and obstacles.

WARNING

The Talon should be disconnected from the power source when it is not in use or is off the water. When connecting the power-supply cables of the Talon to the battery or power switch, ensure that they are not kinked or subject to chafe and route them in such a way that persons cannot trip over them. Before using the Talon make sure that the insulation of the power cables is not damaged. Disregarding these safety precautions may result in electric shorts of battery(s) and/or the product. Always disconnect the Talon from battery(s) before cleaning or checking the Talon. In the event of unexpected operation, remove power leads from the battery. Avoid submerging the complete product as water may enter and considerable damage to the product can occur. This damage will not be covered by warranty. The constant noise pressure level of the Talon during use is less than 70dB(A). The overall vibration level does not exceed 2,5 m/sec².

WARNING

Take care that neither you nor other persons approach the Talon Spike too closely while operating, neither with body parts nor with objects. The Talon is powerful and may endanger or injure you or others. While the Talon is operating, watch out for persons swimming and for floating objects. Persons who lack the ability to run the Talon or whose reactions are impaired by alcohol, drugs, medication, or other substances are not permitted to use this product.

CAUTION

Never leave the boat unattended with the Talon as your only boat anchor. Talon is not intended to provide primary anchorage.

WARNING

It is recommended to only use Johnson Outdoors approved accessories with your Talon. Using non-approved accessories including those used to mount or control your product may cause damage, unexpected operation and injury. Be sure to use the product and all approved accessories, including remotes, safely and in the manner directed to avoid accidental or unexpected operation. Keep all factory installed parts in place including motor, electronic and accessory covers, enclosures and guards. Failure to adhere to this warning may affect your warranty.

WARRANTY

WARRANTY ON TALON SHALLOW WATER ANCHOR

Johnson Outdoors Marine Electronics, Inc. ("JOME") extends the following limited warranty to the original retail purchaser only. Warranty coverage is not transferable.

Minn Kota Limited Five-Year Warranty on Mechanical Parts

(All except, Control Board, Motor, Remote, Bracket, and Spike)*

Johnson Outdoors Marine Electronics, Inc. warrants to the original purchaser that the purchaser's entire Minn Kota Talon shallow water anchor's mechanical parts are free from defects in materials and workmanship appearing within five (5) years after the date of purchase. Johnson Outdoors Marine Electronics, Inc. will (at its option) either repair or replace free of charge, any mechanical parts found to be defective during the term of this warranty. Such repair or replacement shall be the sole and exclusive liability of Johnson Outdoors Marine Electronics, Inc. and the sole and exclusive remedy of the purchaser for breach of this warranty. **The spike is covered by the 5 year mechanical parts warranty (part plus labor to install). After the 5 year mechanical parts warranty the spike will be covered by the limited lifetime warranty (part only).*

Minn Kota Limited Two-Year Warranty on Electrical Parts

(Control Board, Motor, Remote)

Johnson Outdoors Marine Electronics, Inc. warrants to the original purchaser that the purchaser's Minn Kota Talon shallow water anchor's electrical parts are free from defects in materials and workmanship appearing within two (2) years after the date of purchase. Johnson Outdoors Inc. will, at its option, either repair or replace, free of charge, any electrical parts, found to be defective during the term of this warranty. Such repair or replacement shall be the sole and exclusive liability of Johnson Outdoors Marine Electronics, Inc. and the sole and exclusive remedy of the purchaser for breach of this warranty.

Minn Kota Limited Lifetime Warranty on the Spike

Johnson Outdoors Marine Electronics, Inc. warrants to the original purchaser that the spike of the purchaser's Minn Kota Talon shallow water anchor is free from defects in materials and workmanship appearing within the original purchaser's lifetime. Johnson Outdoors Marine Electronics, Inc. will provide a new spike, free of charge, to replace any spike found to be defective more than five (5) years after the date of purchase. Providing a new spike shall be the sole and exclusive liability of Johnson Outdoors Marine Electronics, Inc. and the sole and exclusive remedy of the purchaser for breach of this warranty; and purchaser shall be responsible for installing, or for the cost of labor to install, any new spike provided by Johnson Outdoors Marine Electronics, Inc.

Terms and Conditions

These limited warranties do not apply to products used in saltwater (except the Chargers, Talon, and Riptide models) or commercially, nor do they cover normal wear and tear, blemishes that do not affect the operation of the product, or damage caused by accidents, abuse, alteration, modification, misuse or improper care or maintenance. **DAMAGE CAUSED BY THE USE OF OTHER REPLACEMENT PARTS NOT MEETING THE DESIGN SPECIFICATIONS OF THE ORIGINAL PARTS WILL NOT BE COVERED BY THIS LIMITED WARRANTY.** The cost of normal maintenance or replacement parts which are not defective are the responsibility of the purchaser.

Minn Kota Service Information

To obtain warranty service in the U.S., the product believed to be defective, and proof of original purchase (including the date of purchase), must be presented to a Minn Kota Authorized Service Center or to Minn Kota's factory service center in Mankato, MN. Any charges incurred for service calls, transportation or shipping/freight to/from the Minn Kota Authorized Service Center or factory, labor to haul out, remove, re-install or re-rig products removed for warranty service, or any other similar items are the sole and exclusive responsibility of the purchaser. Products purchased outside of the U.S. must be returned prepaid with proof of purchase (including the date of purchase and serial number) to any Authorized Minn Kota Service Center in the country of purchase. Warranty service can be arranged by contacting a Minn Kota Authorized Service Center or by contacting the factory at 1-800-227-6433 or email service@minnkotamotors.com. **Products repaired or replaced will be warranted for the remainder of the original warranty period [or for 90 days from the date of repair or replacement, whichever is longer]. For any product that is returned for warranty service that JOME finds to be not covered by or not in breach of this limited warranty, there will be a billing for services rendered at the prevailing posted labor rate and for a minimum of at least one hour.**

NOTICE: Do not return your Minn Kota product to your retailer. Your retailer is not authorized to repair or replace products.

NOTICE: THERE ARE NO EXPRESS WARRANTIES OTHER THAN THESE LIMITED WARRANTIES. IN NO EVENT SHALL ANY IMPLIED WARRANTIES INCLUDING ANY IMPLIED WARRANTIES OF MERCHANTABILITY OR FITNESS FOR PARTICULAR PURPOSE, EXTEND BEYOND THE DURATION OF THE RELEVANT EXPRESS LIMITED WARRANTY. IN NO EVENT SHALL JOME BE LIABLE FOR PUNITIVE, INDIRECT, INCIDENTAL, CONSEQUENTIAL OR SPECIAL DAMAGES. Without limiting the foregoing, JOME assumes no responsibility for loss of use of product, loss of time, inconvenience or other damage.

Some states do not allow limitations on how long an implied warranty lasts or the exclusion or limitation of incidental or consequential damages, so the above limitations and/or exclusions may not apply to you. This warranty gives you specific legal rights and you may also have other legal rights which vary from state to state.

KNOW YOUR BOAT

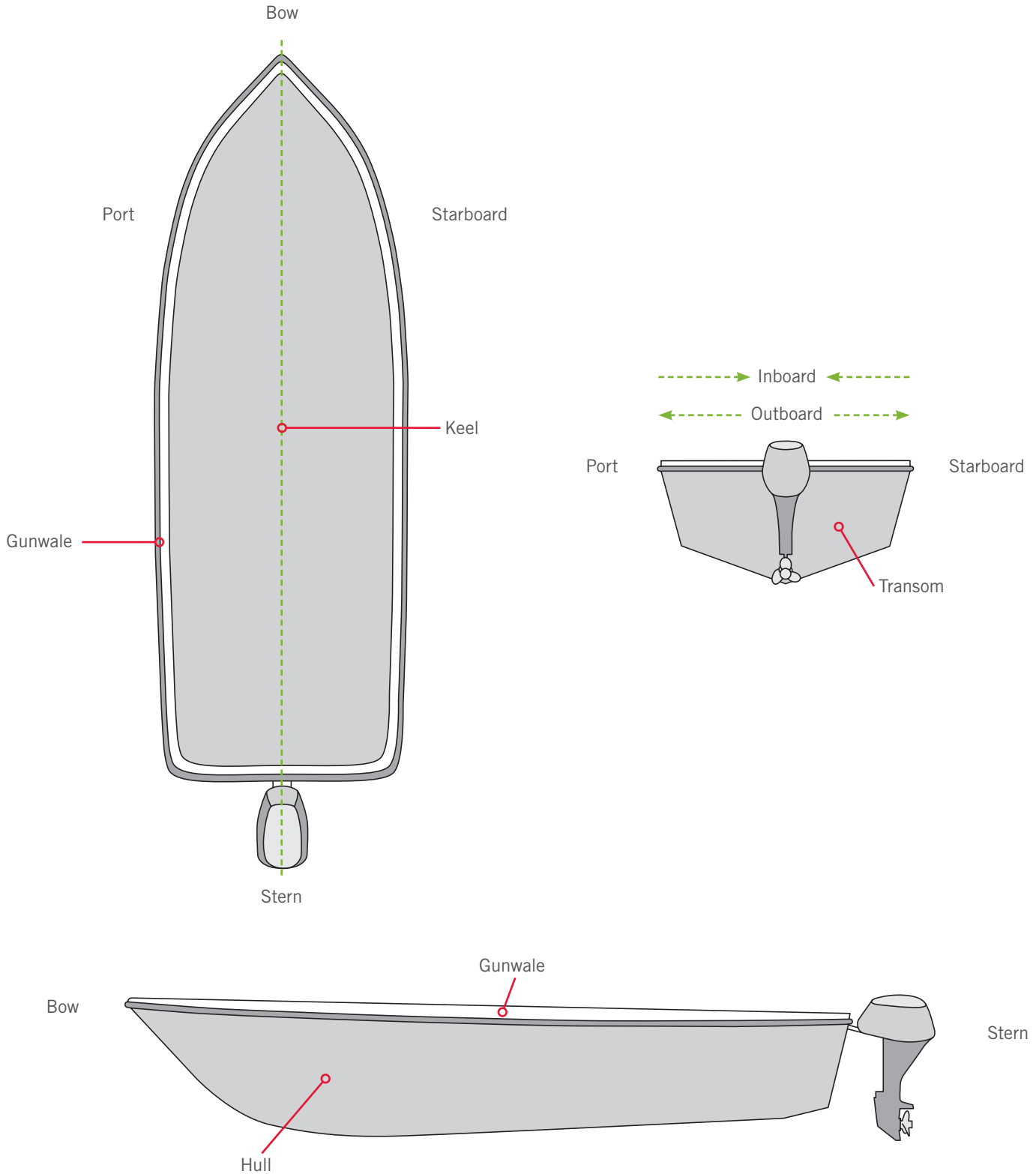

FEATURES



NOTICE: Specifications subject to change without notice. This diagram is for reference only and may differ from your actual Talon.

INSTALLATION

INSTALLING THE TALON

Your new Talon includes the hardware you will need to install it directly to the transom of your boat. If you have an irregular shaped transom that cannot accept a direct mount, or you prefer to mount the Talon with an adapter bracket for ease of mounting and removal, please visit minnkotamotors.com for details on our Talon adapter brackets. For installation with a Talon adapter bracket, refer to the installation instructions provided with the bracket. For compatible Talon adapter brackets, to locate the nearest dealer, or for additional product support, please visit minnkotamotors.com. To install the Talon directly to the boat, please follow the directions provided in these installation instructions. Please review the parts list, mounting considerations and tools needed for installation prior to getting started.

INSTALLATION PARTS LIST

Item / Assembly	Part #	Description	Qty.
A Items 2-12	2994903	TALON HARDWARE BAG ASSY	1
2	2373525	BOLT-5/16-18 X 3 1/2" HHCS SS	4
4	2371749	WASHER-FLAT 5/16 SS	4
6	2371752	WASHER-FENDER, 5/16, SS	4
8	2223100	NUT-5/16-18 NYLOCK S/S	4
10	2378608	ANTI SEIZE TUBE, 4CC, TALON	1
12	2014802 ▲	BAG-ZPLCK(4x6)4ML ANTISTATIC	1
B	✳	TALON ASSEMBLY	1
14	2372930	CORD RETAINER	2
16	2390801	LANYARD, REMOTE	2
C	2994150	NEW BT TRANSMITTER ASSY	2
18	2371829	BRACKET, RMT DASH MNT HLDR	1
20	2376447	WATER SHIELD, DEFLECTOR - TALON 2	1
22	2371754	#8 WASHER, 1/2" OD, SS	2
24	2263434	#8-18 X 1 SS PPH	2
D Items 26-38	2778725	MOUNTING BRACKET ASSEMBLY	1
26	2371758	WASHER-3/8 HD FLAT SS	4
28	2378716	GUARD, EXTRUSION BRACKET	4
30	2383459	SCREW-3/8-24 X 1.25 HHCS SS	4
32	3391706	WASHER-LOCK 3/8"	4
34	2378725	BRACKET-TILT, MACH (SUB)	1
36	2373138	3/8-24 NYLOK NUT, SS	4
38	2373815	TALON MOUNTING STRAP	2
40	2377170 ▲	MANUAL, TALON BT	1
42	2377171 ▲	MANUAL, INSTAL GUIDE T3	1

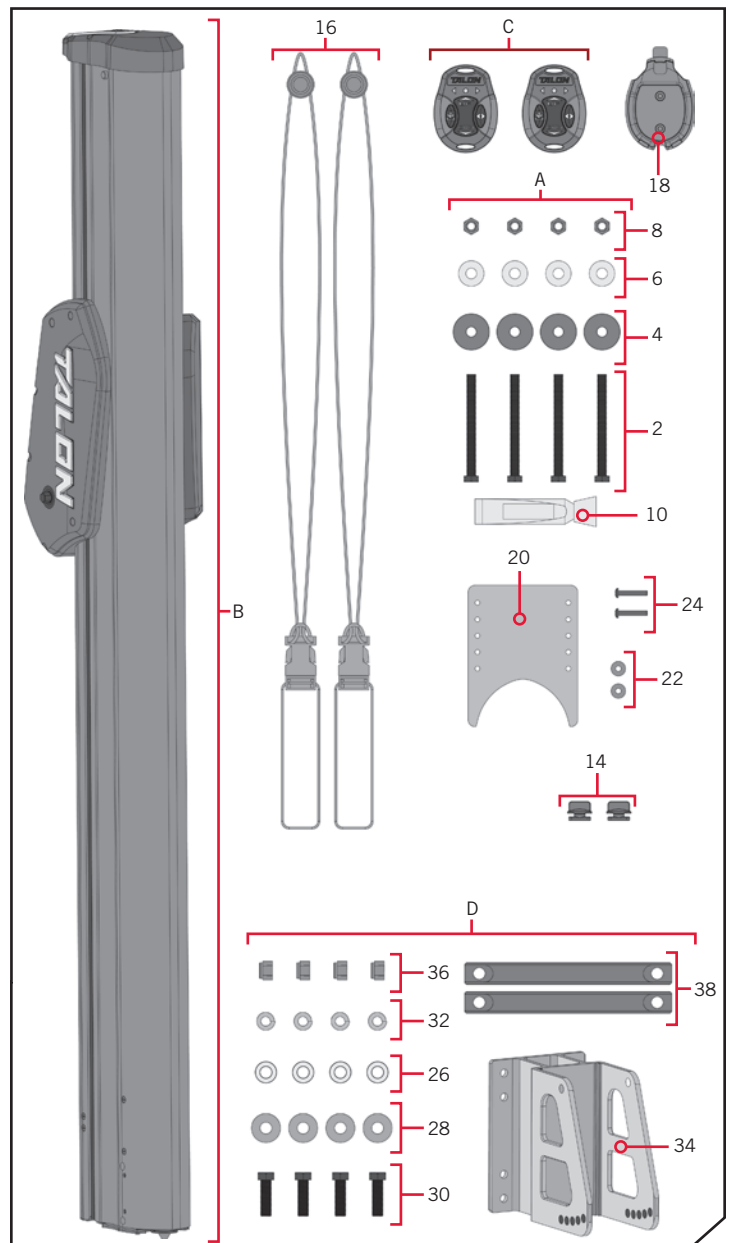

✳ This part is included in an assembly and cannot be ordered individually.

▲ Not shown on Parts Diagram.

MOUNTING CONSIDERATIONS

Minn Kota recommends mounting the Talon directly to the transom of the boat with the Mounting Bracket. Your Talon comes complete with all the necessary hardware to mount directly to the transom/stern. The Talon may also be mounted using an optional adapter plate when direct transom mounting is not possible or desired due to obstructions or irregular-shaped transoms. For more information on universal adapter brackets and other Minn Kota® Talon accessories, please visit minnkotamotors.com. When using an adapter bracket to mount the Talon, please use the instructions included with the accessory.

In order to use the direct mount installation, the following conditions need to be met:

1. Unobstructed Mounting - When selecting the Talon Mounting Bracket mounting location, examine your boat to ensure that you will not drill into any obstructions and that the hardware will be accessible for assembly.

2. Unobstructed Deployment and Retraction - Talon is designed to mount on either the port or starboard side of the transom. Talon must have a clear, unobstructed path to deploy. Check to make sure that your proposed location will allow the anchor to deploy and retract without hitting trim tabs, poling platforms, ladders, engine or other obstructions. You should also consider your fishing methods when selecting the mounting location.

3. Transom to Talon Clearance - The Talon Mounting Bracket included with your unit will allow for approximately 6" of clearance from the transom to the front edge of the deploying anchor. **When mounting the Talon Mounting Bracket directly to the transom, Minn Kota suggests installing the Mounting Bracket in the highest possible location.** This will provide the most clearance, and the greatest amount of vertical and angular adjustability.



View accessories available for your Talon at minnkotamotors.com.

NOTICE: Some boats may be manufactured with a reverse transom angle. In these cases, the Talon mounting bracket may be mounted upside-down to compensate for the reverse angle.

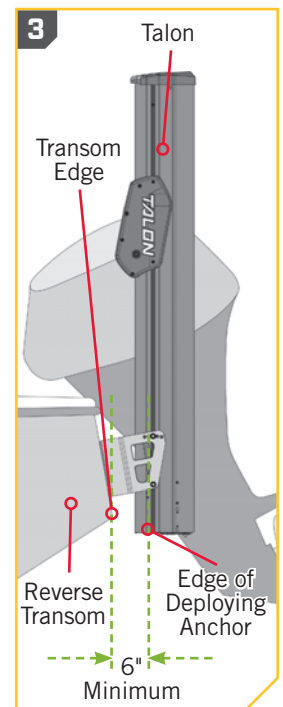
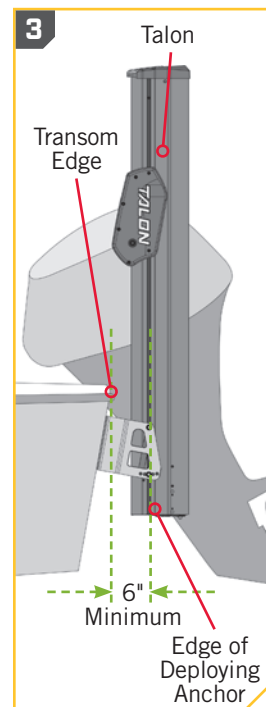
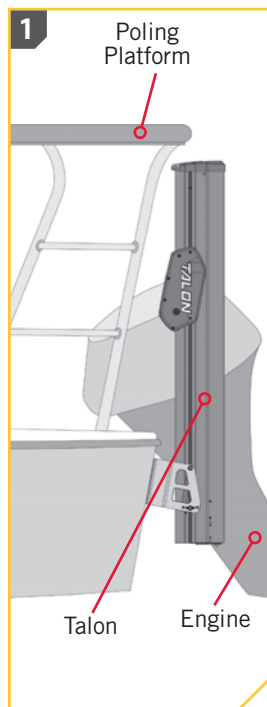
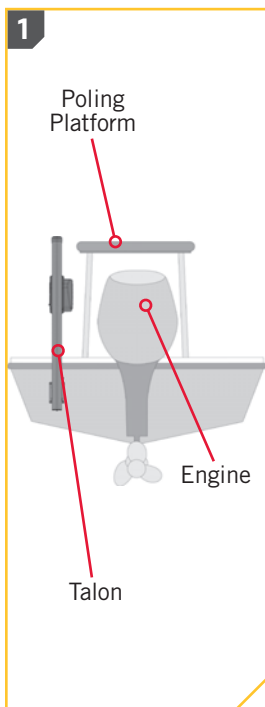

INSTALLING THE TALON

4. Talon to Hull Clearance - The bottom edge of the Talon should never be less than 4" above the hull directly below the Talon to prevent spray and drag conditions.

5. Talon to Engine Clearance - When selecting a mounting location make sure that no interference exists between the Talon and your engine during normal operation. Once you have selected your mounting location, trim the engine all the way up and all the way down, and steer the engine fully to and away from the side selected. Ensure there is a minimum of two to three inches of clearance from any point on the Talon.

NOTICE: All bass boats should mount the Talon as flush with the bottom of the Talon mounting bracket as possible to mitigate spray while underway.

NOTICE: In some instances, boat manufactures have begun to make hollow boat Transoms. We recommend speaking to your local boat dealer or OEM Manufacturer for mounting recommendations.

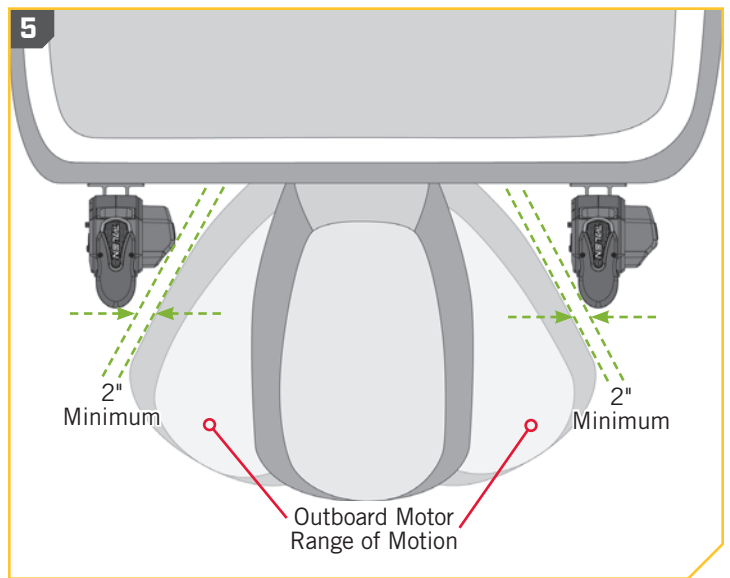
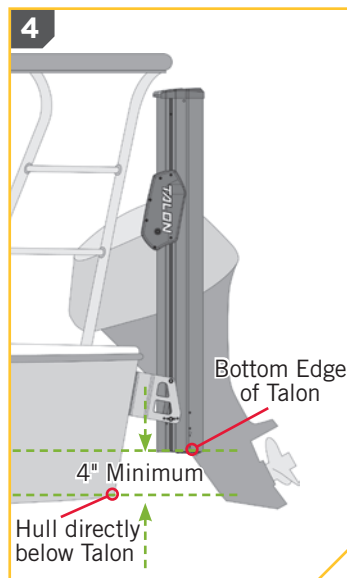
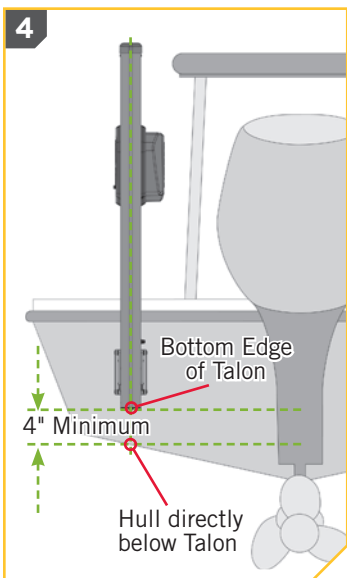

If these conditions are not met, please consider using an optional adapter plate. There are many adapter plates that allow for greater adjustability of the mount and allow for greater clearances to operate the Talon. Please visit minnkotamotors.com to learn more about selecting and installing an adapter plate.

CAUTION

Follow all instructions and heed all safety considerations. Minn Kota recommends having a second person help with installation. Not following proper installation and rigging instructions may result in injury. Mounting the Talon too low can cause undue drag from the Talon or Mounting Bracket when operating the boat. It is important to mount the Talon as recommended to avoid unsafe driving conditions.

TOOLS AND RESOURCES REQUIRED >

- Drill
- 5/16" Drill Bit
- 1/2" Box End or Socket Wrench
- 9/16" Box End or Socket Wrench
- Marine Grade Sealant
- Cable Ties
- Tape Measure
- 30ft/lb capacity Torque Wrench
- Pencil or similar marking tool
- Pliers
- A second person to help with installation
- Heat Shrink with Adhesive
- Wire no smaller than 12AWG
- Voltmeter

INSTALLATION >

> Installing the Talon

1

ITEM(S) NEEDED



#D x 1

- a. Review the Mounting Considerations to determine if it is acceptable to complete a direct mount of the Talon Mounting Bracket. If acceptable, position the Mounting Bracket (Item #D) at the selected location and mark the Mounting Holes with a pencil or similar marking tool. Any of the eight Mounting Holes can be used with at least one bolt in each corner of the bracket, or 2 on each side.
- b. Double check that the mounting location is clear to drill holes and then use a Drill with a 5/16" Drill Bit to drill through the Transom/Stern of the boat on the marked locations.

NOTICE: When drilling the marked holes, make sure that the drill bit is perpendicular to the Transom/Stern of the boat and that the holes are being drilled straight. Not drilling the holes straight will give the mounting hardware a poor fit.

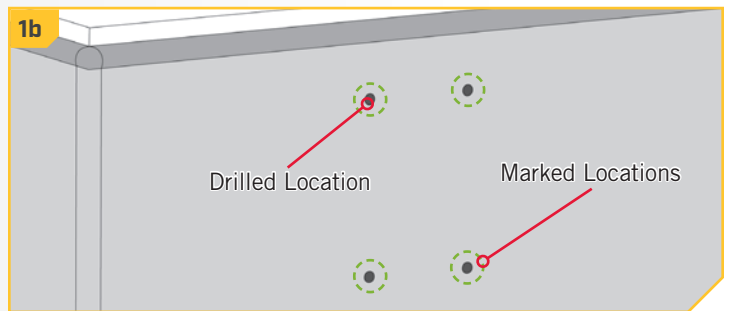
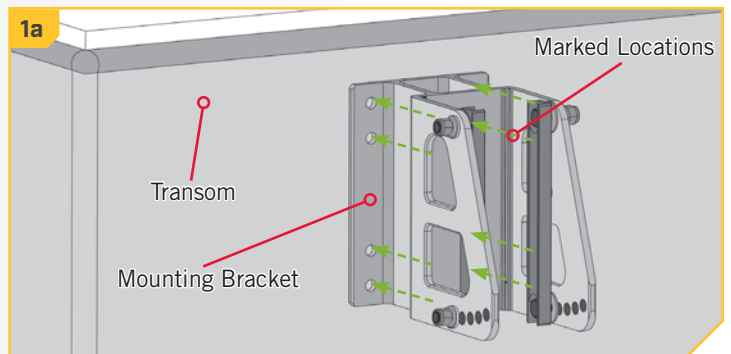

2

- c. Place a 1/8" bead of Marine Grade Sealant on the Transom of the boat around the drilled holes.
- d. Place the Marine Grade Sealant on the face of the Mounting Bracket that will contact the boat Transom/Stern when mounted. Keep the sealant approximately centered between the outside edge of the Mounting Bracket and the Mounting Holes. Once the sealant is in place, align the Mounting Bracket in the desired orientation with the holes that were drilled in the Transom/Stern.

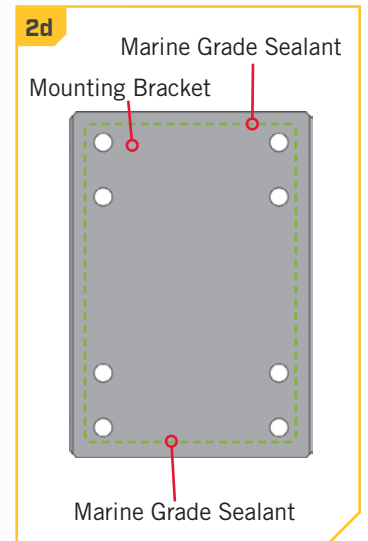
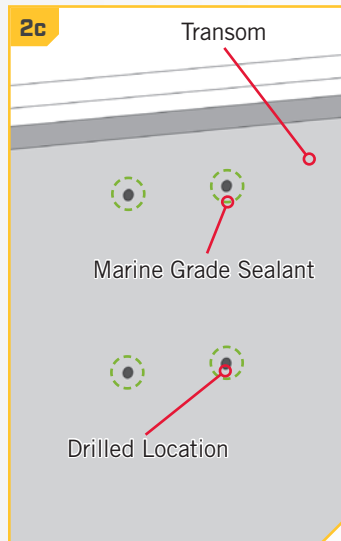

INSTALLING THE TALON

3

ITEM(S) NEEDED

#2 x 4

#4 x 4

#6 x 4

#8 x 4

- e. Take each of the four 3-1/2" Stainless Steel Bolts (Item #2) and place one Flat Washer (Item #4) on them. Place one Bolt in each of the Mounting Holes so that it passes through the Mounting Bracket and the drilled holes on the transom of the boat.
- f. Place a Fender Washer (Item #6) on the end of each Bolt on the inside of the Transom and secure each with a Nylock Nut (Item #8). Tighten the bolts with a 1/2" Box End or Socket Wrench. Do not over-tighten.

NOTICE: To prevent seizing of the stainless steel hardware, do not use high speed installation tools. Applying an anti-seize will help prevent seizing.

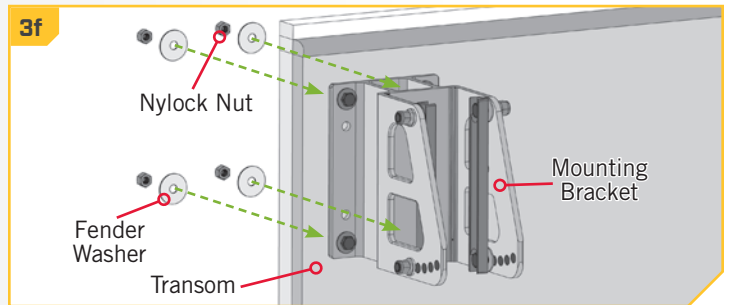
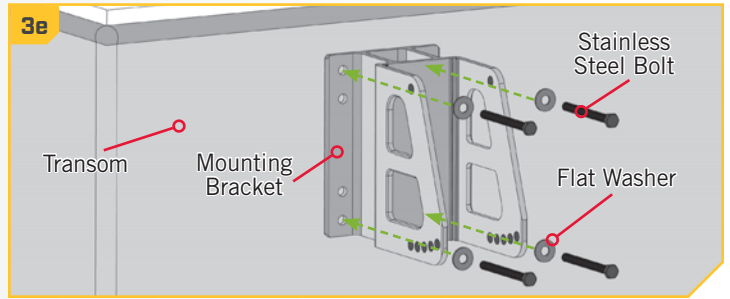

4

- g. Once the Mounting Bracket is secured, note the Mounting Straps located on the inside of the Mounting Bracket. The Mounting Straps need to be adjusted so that they are as perpendicular as possible to the waterline. The five Angular Adjustment Holes located on one end of the Mounting Straps allows for 25 degrees of motion to accommodate the variability of different transom styles.
- h. If the Mounting Straps are not perpendicular, use a 9/16" Box End or Socket Wrench to adjust the Nylock Nuts. The Bolt that passes through the Mounting Strap, opposite from the Angular Adjustment Holes should be loosened, but not removed.

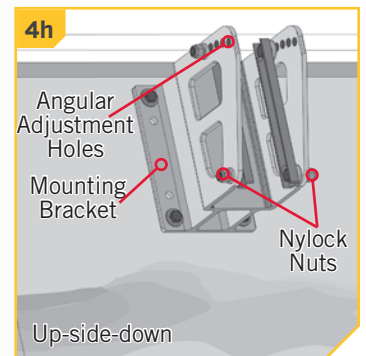
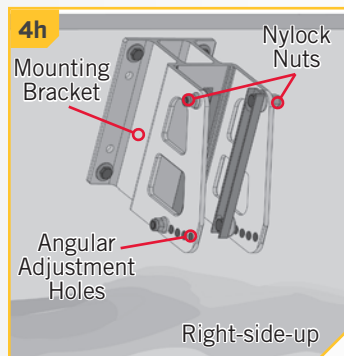
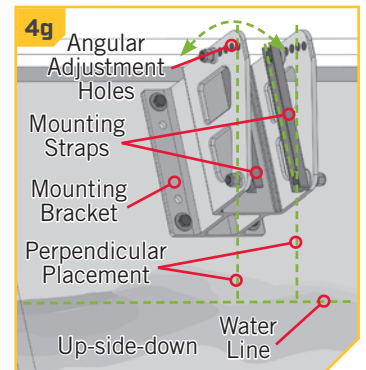
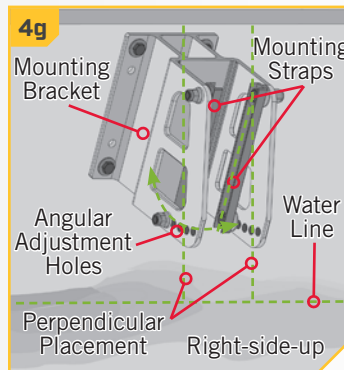

5

- i. Next, note the position of the nuts, washers and screws holding the Mounting Strap in place. The Hex Head Cap Screws pass from the inside to the outside of the bracket. They first pass through the Mounting Strap, then a Guard Washer, then the Mounting Bracket. On the outside of the bracket, the screw first holds a Flat Washer and then a Lock Washer before being secured with a Nylock Nut.
- j. After the appropriate Nylock Nut has been loosened, locate the Nylock Nut opposite of the loosened one on the Mounting Strap and remove it.
- k. Adjust the Mounting Straps so that they are as perpendicular to the waterline as possible.



CAUTION

Do not use the Mounting Bracket or Talon as a step to enter the boat. The bracket will be slippery when wet and is not designed to support people. Using this product as a step may result in injury.

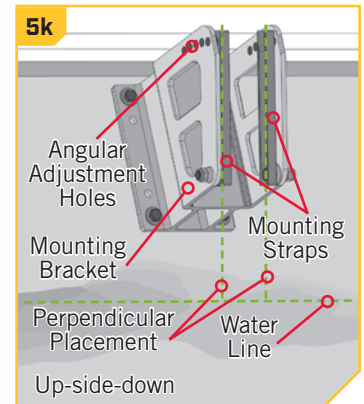
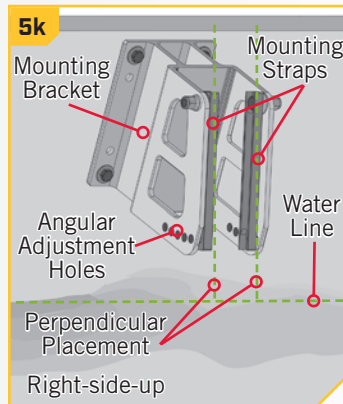
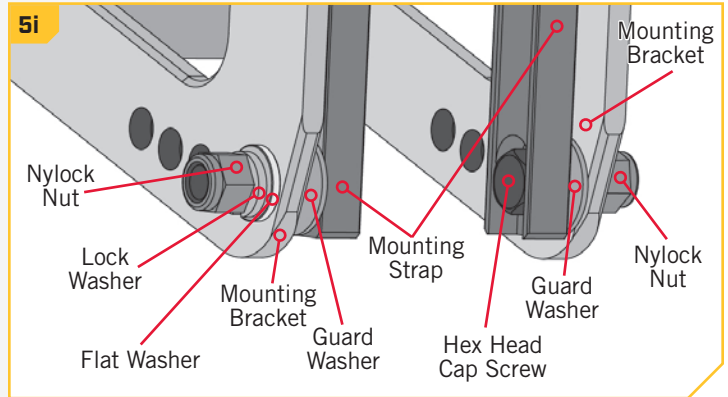

6

- l. Once perpendicular, replace the hardware that was removed by selecting one of the five Angular Adjustment Holes that will support the Mounting Strap at the most perpendicular position.
- m. To replace the bolts, pass them from the inside to the outside, through the Mounting Strap, then the Guard Washer, then the Mounting Bracket, a Flat Washer and Lock Washer. Then loosely secure with a Nylock Nut. The nuts will be fully secured later in the installation.

NOTICE: To prevent seizing of the stainless steel hardware, do not use high speed installation tools. The hardware holding the Mounting Straps in place has a pre-applied anti-seize.

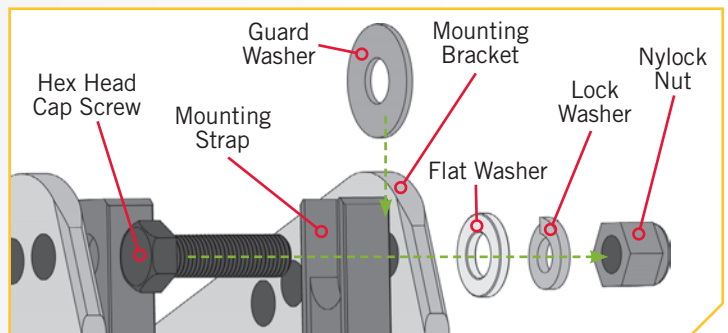
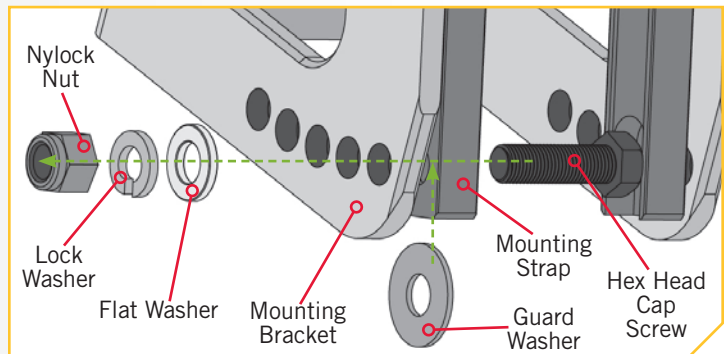

INSTALLING THE TALON

7

ITEM(S) NEEDED



NOTICE: We recommend a second person to help with this step of the installation.

- n. Next the Talon Assembly should be installed on the Mounting Bracket. Take the Talon Assembly (Item #B) and notice that there is an Assembly Track located on both sides of the Talon.
- o. When the Talon is properly oriented as it would be installed, there is a single Vertical Stop Bolt located on the Starboard side of the Talon along the Assembly Track. The Vertical Stop Bolt is used as a reference point or guideline to stop the Talon and position the Mounting Straps in the Assembly Track. Ensure that the Vertical Stop Bolt is secured in the approximate final position.
- p. Carefully lift the Talon Assembly into the Mounting Bracket and align the Mounting Straps with the Assembly Track. Slide the Guard Washers to the inside wall of the Mounting Bracket, so that they sit between it and the Talon Assembly. Slide the Talon Assembly down the Assembly Tracks until it comes in contact with the Vertical Stop Bolt.

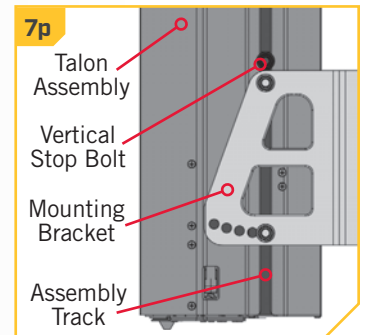
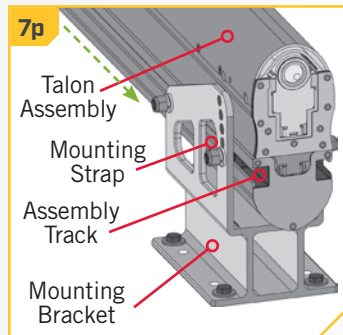
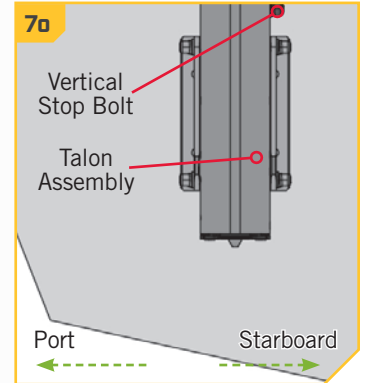
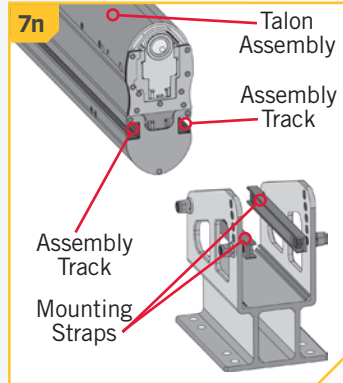

INSTALLING THE WATER DEFLECTION SHIELD

8

- q. While supporting the Talon Assembly, adjust it and the Vertical Stop Bolt up or down in the Mounting Bracket so that the bottom of the Talon Assembly is not less than 4 inches above the Bottom of the hull of the boat, or the waterline of the boat. Once in place, temporarily tighten the Vertical Stop Bolt.
- r. Double check the placement of the Talon Assembly and make sure it meets all of the mounting considerations. Make any adjustments as necessary. When the position of the Talon Assembly is acceptable, secure the four Hex Head Cap Screws and Nylock Nuts holding the Mounting Straps in place with a 9/16" Box End or Socket Wrench. Use a torque wrench to tighten to a recommended torque of 20 to 30 ft-lbs. Tighten the Vertical Stop Bolt.

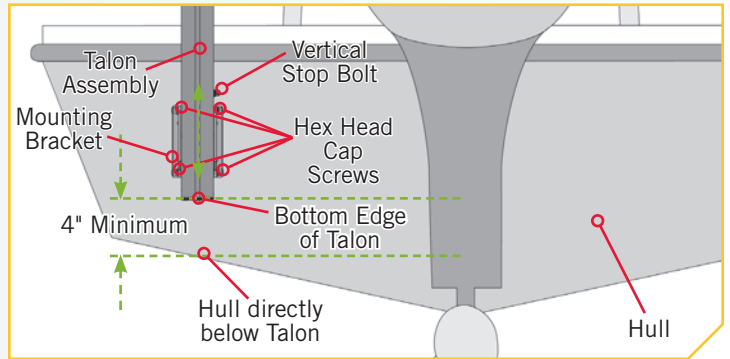

NOTICE: Additional adjustments may need to be made to the mount after a trial run with the boat on the water. Periodically re-tighten the four nuts and screws to 20 to 30 ft-lbs.

CAUTION

Check tension of the 4 vertical adjustment nuts after initial use and periodically thereafter to ensure they are at the recommended torque of 20 to 30 ft-lbs.

Installing the Water Deflection Shield

The Water Deflection Shield is designed to prevent undesirable spray conditions while the boat is traveling over water. The Water Deflection Shield is installed after the Talon is successfully installed on the boat. Each installation will be different and is dependent upon the position of the Talon as it sits in the Mounting Bracket. The Water Deflection Shield is installed on the bottom side of the Mounting Bracket as it is attached to the boat. The installation is designed to be adjustable to suit different angular positions.

1

ITEM(S) NEEDED

#20 x 1

- a. Make sure that the Talon is positioned as recommended and installed properly by reviewing the Installing the Talon section of this manual.
- b. Once complete, take the Water Deflection Shield (Item #20), and determine where it will be installed on the Mounting Bracket. When placed properly, the curved edge of the shield will sit against the surface of the Talon Assembly that sits inboard in the Mounting Bracket.

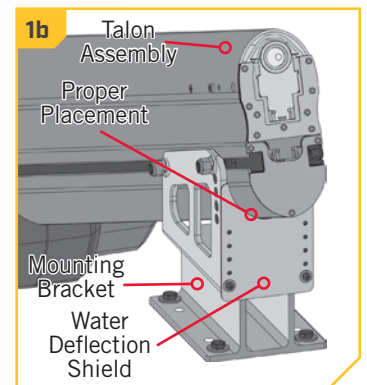
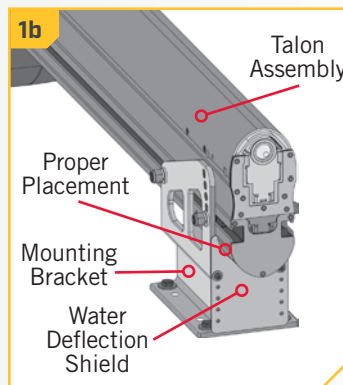

INSTALLING THE POWER CABLE AND DEPLOYMENT NOTIFICATION ALARM WIRE

2

- c. Align the closest set of holes in the shield with the holes in the bottom of the Mounting Bracket. The set of holes used on the shield will vary for each individual installation.

NOTICE: The Water Deflection Shield will always be installed on the bottom side of the Mounting Bracket regardless of the orientation that the Mounting Bracket was installed. There should be no gap between the shield and the Talon.

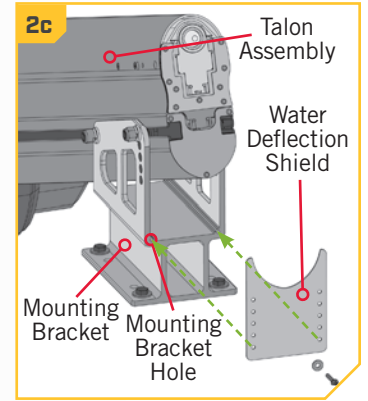
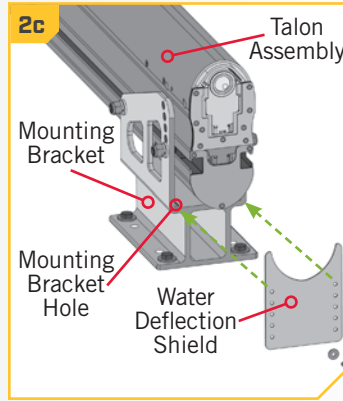

3

ITEM(S) NEEDED

- ▮ #24 x 1 ● #22 x 1

- d. Take two each of the 1/2" Washers (Item #22) and two of the 1" Phillips Pan Head Screws (Item #24) to attach the shield to the Mounting Bracket. Place one washer on each of the screws. The screw should pass through a washer, then the Water Deflection Shield and into the Mounting Bracket. Secure the screws using a #2 Screwdriver.

NOTICE: To prevent seizing of the stainless steel hardware, do not use high speed installation tools. Applying an anti-seize may help prevent seizing.

NOTICE: If you adjust the angle of your Talon after this step is complete, you will need to re-adjust the placement of the Water Deflection Shield to ensure proper functionality.

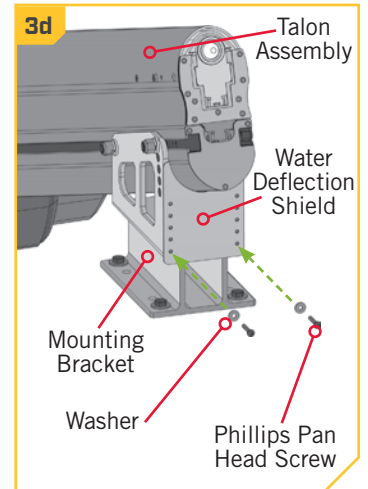
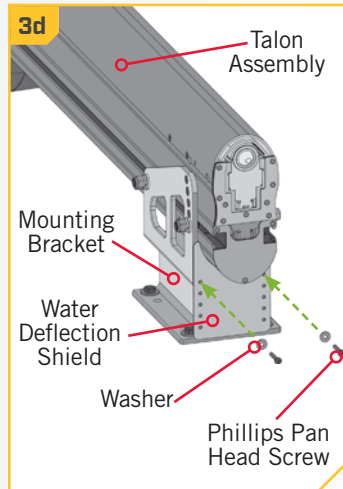

INSTALLING THE POWER CABLE AND DEPLOYMENT NOTIFICATION ALARM WIRE

› Installing the Power Cable and Deployment Notification Alarm Wire

The Talon Power Cable consists of a 30 amp in-line resettable fuse on the positive lead, a negative lead, and a Deployment Notification Alarm Wire. The Deployment Notification Alarm Wire is a green wire that comes from the Power Cable and, when installed, is used to sound an alarm, when the Ignition Switch is turned to the "on" position with the Talon deployed. When connected and the Talon is properly stowed, no tone will be emitted when the Ignition Switch is turned "on". Minn Kota recommends connecting the Power Cable to the starting battery through a battery selector/power disconnect switch. The Talon does draw a small amount of residual current from the battery even when not in use. By connecting the positive lead of the Talon Power Cable through a battery selector/power disconnect switch it will disconnect power to the Talon when the Power Switch is "off". The Power Switch must have a minimum amp rating of 60 amps per Talon. If you are not connecting the Talon to a battery selector/power disconnect switch, it can be connected directly to the starting battery, but should be disconnected from power when the Talon is not in use. The Power Cable can be routed in a number of different ways depending on a boat's unique setup. It is recommended to route the Power Cable using the shortest and cleanest route from the Talon to the battery connection. Please see the Battery & Wiring Installation section of this Manual for more information.

NOTICE: It is not necessary to connect the Deployment Notification Alarm Wire in order for the Talon to function, but it is needed to comply with warranty requirements.

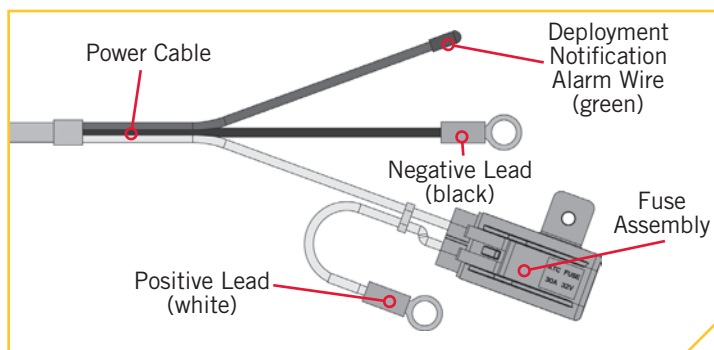

1

- a. Inspect the selected wire routing and make sure that there are no sharp edges, obstacles or obstructions that may damage the Power Cable. If routing along the gas outboard wire or a cable harness assembly, you may need to open any wire ties or clamps to allow the Power Cable to pass through.
- b. Carefully route the Power Cable along the intended path. Remove any slack in the Power Cable so that it routes without any bulges, lumps or kinks.
- c. The Power Cable for the Talon splits at the end to include the positive lead with a fuse, a negative lead and then the Deployment Notification Alarm Wire. If you choose not to connect the Deployment Notification Alarm, skip to step 4.

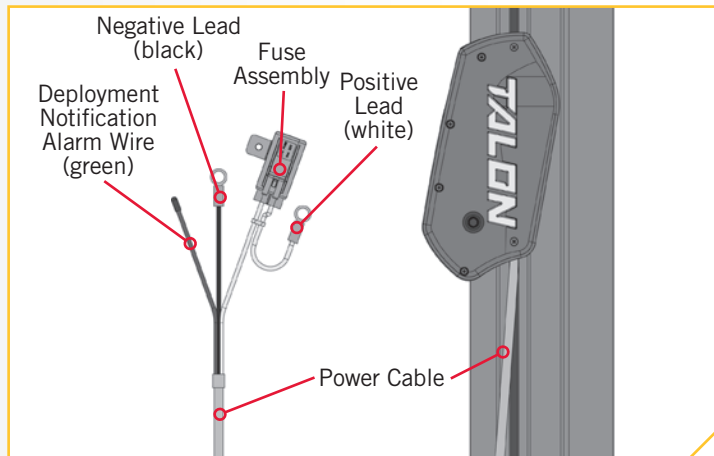

NOTICE: If unsure of how to wire the Talon Power Cable, please see a qualified marine technician.

INSTALLING THE POWER CABLE AND DEPLOYMENT NOTIFICATION ALARM WIRE

2

- d. The optional Deployment Notification Alarm will be connected to the side of the 12 volt Ignition Switch that lacks power when the switch is turned "off". Use a voltmeter to determine where this connection exists. 12 volts should be present at the connection when the ignition switch is turned to the "on" position and no voltage should be present when the switch is turned to the "off" position.
- e. Next determine if the Deployment Notification Alarm Wire is long enough to reach the intended connection. If additional wire is needed, use a wire that is no smaller than 12 AWG.

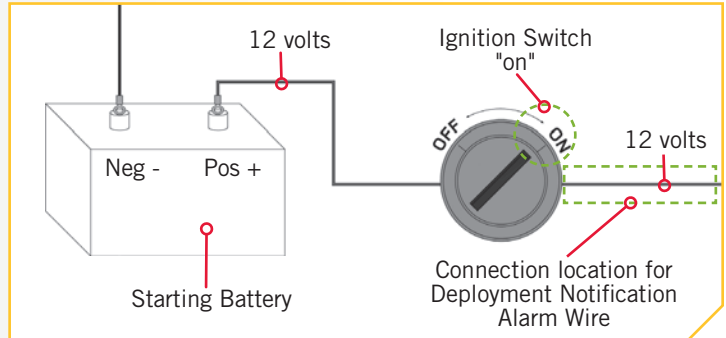
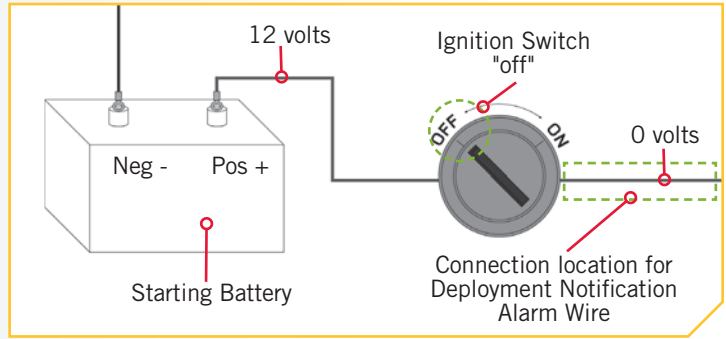

3

- f. Be sure that the Ignition Switch is turned to the "off" position. Cut off the sealed end of the green Deployment Notification Alarm Wire on the Power Cable and splice it to the 12 AWG minimum gauge wire, or if there is enough slack in the wire, directly to the switched side of the Ignition Switch that was just tested. Use an adhesive filled heat shrink to waterproof and secure the splice.
- g. If an additional wire was used, close the final connection between the Ignition Switch and the additional 12 AWG wire and seal with an adhesive filled heat shrink.

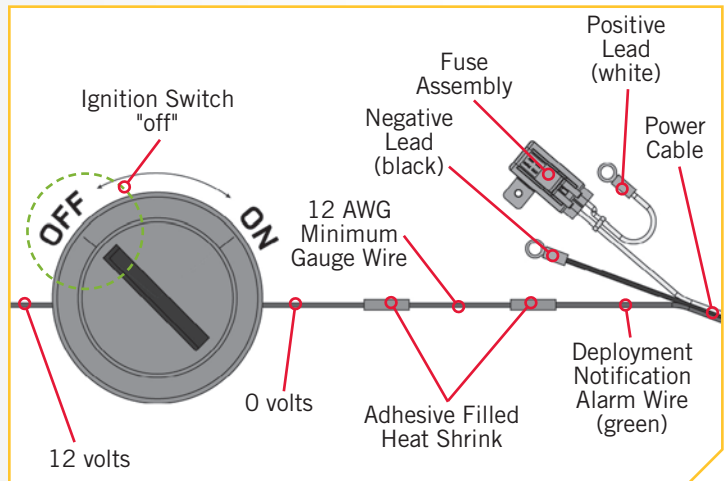

NOTICE: When properly installed the alarm will only sound when the ignition key is turned on when the Talon is not fully retracted.

INSTALLING THE POWER CABLE AND DEPLOYMENT NOTIFICATION ALARM WIRE

4

- h. If connecting to an optional battery selector/power disconnect switch, turn it to the "off" position before connecting the Power Cable.
- i. The positive white lead wire coming from the Power Cable has a red band and contains the Fuse Assembly. This wire connects to the Starting Battery positive (+) terminal or the battery selector positive. Connect the black negative lead of the Power Cable to the Starting Battery negative (-) terminal. If additional wiring needs to be used to make the connections, please see the Battery and Wiring Installation Section of this manual. Secure any splices with an adhesive filled heat shrink tube. Make sure that the Fuse Assembly is used.

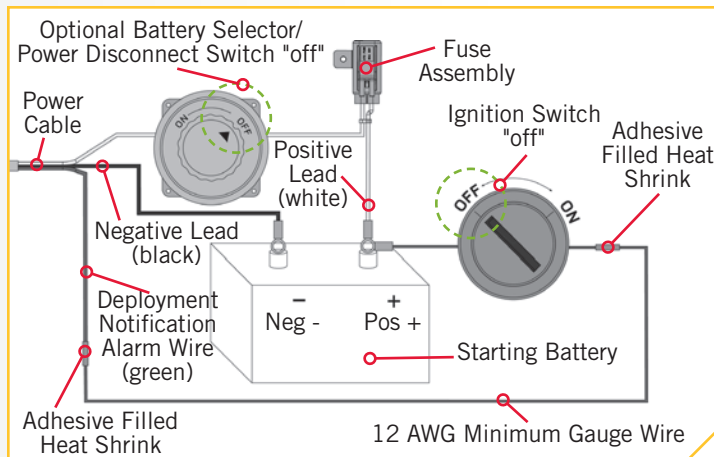

NOTICE: For proper American Boat & Yacht Council Compliance, if the Fuse Assembly is removed, the user must install a 30 amp fuse within 7" of the positive battery terminal (+).

5

ITEM(S) NEEDED

 #14 x 2

- j. Once the Power Cable has been routed, connected and secured, the remaining loose cable may be pushed inside the Assembly Track that runs vertically along the outside column of the Talon.

NOTICE: Depending on your wiring, there may be more or less slack in the Power Cable. The Cord Retainers use and placement will vary from installation to installation.

- k. Take the two Cord Retainers (Item #14) and push the t-slot portion of them into the Assembly Track. Once positioned use a pair of pliers to turn the Cord Retainer 90 degrees in the Assembly Track to lock it in place.

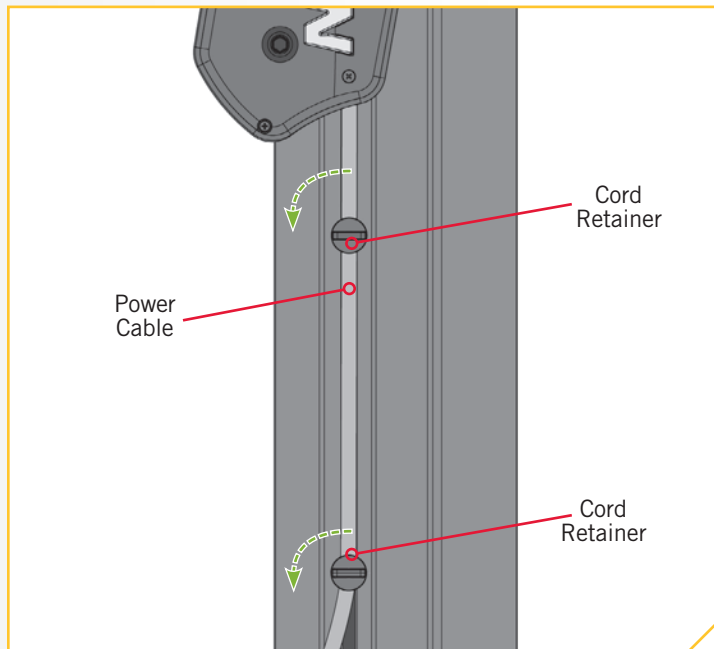





INSTALLING THE POWER CABLE AND DEPLOYMENT NOTIFICATION ALARM WIRE

› Verifying Installation



Once installation is complete, use the following procedure to verify installation and confirm your Talon is ready to use.

1

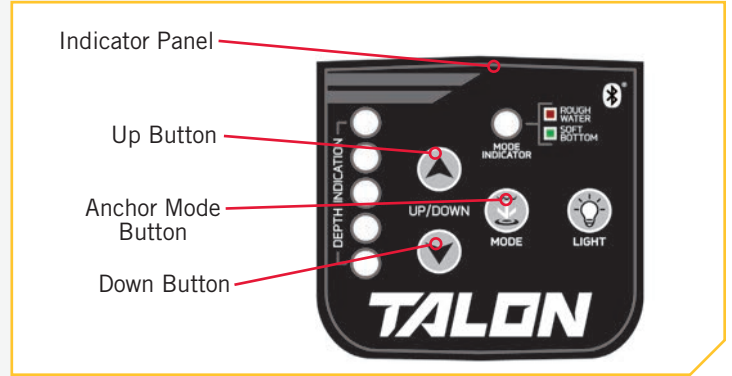



- a. For this test your Talon must be able to deploy and make contact with the ground without hitting any obstructions. Carefully inspect the area around the Talon for any obstructions that may interfere with deployment.
- b. If using a battery selector, or power disconnect switch, turn the selector switch to the “on” position. On the Indicator Panel of the Talon are three buttons needed for this verification, the Up  button, the Down  button and the Mode  button. Press the Mode  button. Confirm that the Mode Indicator is unlit. If it is not, press the Mode button until the Mode Indicator flashes between green and red and then turns off.

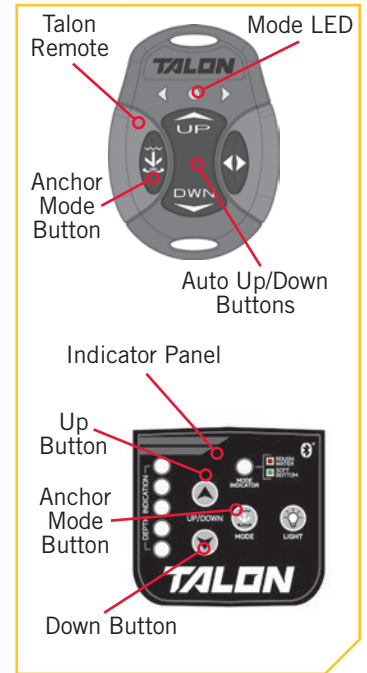
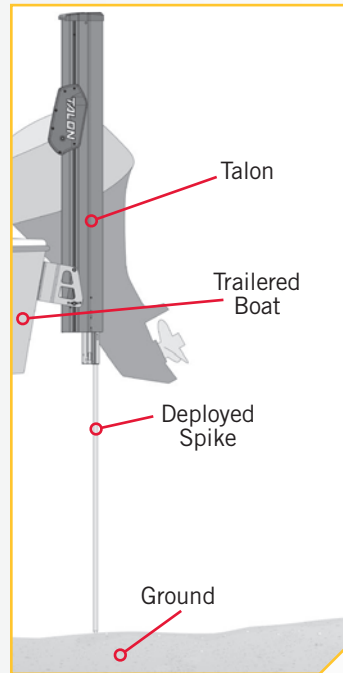

2

- c. Stand clear of the Talon and push the Down  button. The Talon spike will begin to deploy. The Depth Indication LEDs on the Indicator Panel will track the progress of the Talon as the Spike deploys.
- d. When the Spike comes in contact with the ground, the unit will automatically shut off. After the initial shut off, you will hear two (2) additional deploy cycles (or clicks), each 3-seconds apart from the initial ground contact.
- e. If the Talon functions as described above, press the Up  button. The Talon will fully retract. If the Talon does not function as described, double check all wiring connections and verify proper polarity to white and black power leads and retest.



NOTICE: To perform the same test using the remote instead of the buttons on the Indicator Panel, use the Anchor Mode  button, the Up  button, and the Down  button on the remote. To deploy the anchor on the remote, the Down  button must be double pressed.

BATTERY & WIRING INSTALLATION

BOAT RIGGING & PRODUCT INSTALLATION

For safety and compliance reasons, we recommend that you follow American Boat and Yacht Council (ABYC) standards when rigging your boat. Altering boat wiring should be completed by a qualified marine technician. The following specifications are for general guidelines only.

CAUTION

Please read the following information before connecting your Talon(s) to your battery in order to avoid damaging your product and/or voiding your warranty.

CAUTION

These guidelines apply to general rigging to support your Minn Kota product. Powering multiple Talons or additional electrical devices from the same power circuit may impact the recommended conductor gauge and circuit breaker size. If you are using wire longer than that provided with your unit, follow the conductor gauge and circuit breaker sizing table below. If your wire extension length is more than 25 feet, we recommend that you contact a qualified marine technician.

CAUTION

An over-current protection device (circuit breaker or fuse) must be used. Coast Guard requirements dictate that each ungrounded current-carrying conductor must be protected by a manually reset, trip-free circuit breaker or fuse. The type (voltage and current rating) of the fuse or circuit breaker must be sized accordingly. The table below gives recommended guidelines for circuit breaker sizing.

CONDUCTOR GAUGE AND CIRCUIT BREAKER SIZING TABLE

This conductor and circuit breaker sizing table is only valid for the following assumptions:

1. No more than 2 conductors are bundled together inside of a sheath or conduit outside of engine spaces.
2. Each conductor has 105° C temp rated insulation.
3. No more than 5% voltage drop allowed at full power based on published product power requirements.

Max Amp Draw	Circuit Breaker	Wire Extension Length				
		5 feet	10 feet	15 feet	20 feet	25 feet
30 Amps	30 Amp @ 12 VDC	10 AWG	10 AWG	8 AWG	6 AWG	4 AWG

NOTICE: Wire Extension Length refers to the distance from the batteries to the Talon leads. Maximum Amp Draw values only occur intermittently during select conditions and should not be used as continuous amp load ratings.

Reference

United States Code of Federal Regulations: 33 CFR 183 – Boats and Associated Equipment ABYC E-11: AC and DC Electrical Systems on Boats

SELECTING THE CORRECT BATTERIES



SELECTING THE CORRECT BATTERIES

The Talon will operate with any lead acid, marine 12 volt battery. For best results, Minn Kota recommends connecting to the starting battery. Maintain battery at full charge. Proper care will ensure having battery power when you need it, and will significantly improve the battery life. Failure to recharge lead-acid batteries (within 12-24 hours) is the leading cause of premature battery failure. Use a multi-stage charger to avoid overcharging. We offer a wide selection of chargers to fit your charging needs. For more information on battery selection and rigging, please visit minnkotamotors.com.

The Talon draws a small amount of residual current from the battery even when not in use. If the Talon will not be used for more than 5 days, the Talon power leads should be disconnected from the battery. Do not connect the Talon to the same batteries that a trolling motor or other accessories are connected to. It is recommended the Talon be connected to the Starting Battery through a battery selector or power disconnect switch. This will disconnect power to the Talon when the Power Switch is "off". If you are not using a battery selector/power disconnect switch, the Talon may be connected directly to the Starting Battery.

WARNING

Never connect the (+) and the (-) terminals of the same battery together. Take care that no metal object can fall onto the battery and short the terminals. This would immediately lead to a short and extreme fire danger.

For proper ABYC compliance, when the factory fuse has been removed, the user must install a 30A fuse within 7" of the positive battery terminal.

NOTICE: The in-line re-settable 30A fuse is designed to protect the system. If this fuse repeatedly trips, faulty wiring could be the cause and must be corrected. If the re-settable fuse itself is suspect, Minn Kota recommends contacting customer service for a proper replacement.

CONNECTING THE BATTERIES

› 12 Volt Systems

1. If connecting to an optional battery selector/power disconnect switch, turn it to the "off" position prior to connecting the power cable.
2. Connect positive (+) white lead to positive (+) battery terminal, or switch positive.
3. Connect negative (-) black lead to negative (-) battery terminal, or switch negative.

WARNING

Observe proper polarity and follow instructions in your boat owner's manual regarding polarity.



WARNING

- The Talon draws a small amount of residual current from the battery even when not in use. If the Talon is not be used for more than 5 days, or while the battery/batteries are being charged, the Talon power leads should be disconnected from the battery. It is recommended the Talon be connected to the Starting Battery through a battery selector or power disconnect switch. This will disconnect power to the Talon when the Power Switch is "off". If you are not using a battery selector/switch, the Talon may be connected directly to the starting battery.
- Keep lead wire connections tight and solid to the battery or switch terminals.
- The Starting Battery should be located in a ventilated compartment to avoid sparks from combustible materials.



WIRING DIAGRAM

TALON

The following Motor Wiring Diagram applies to all Talon models.

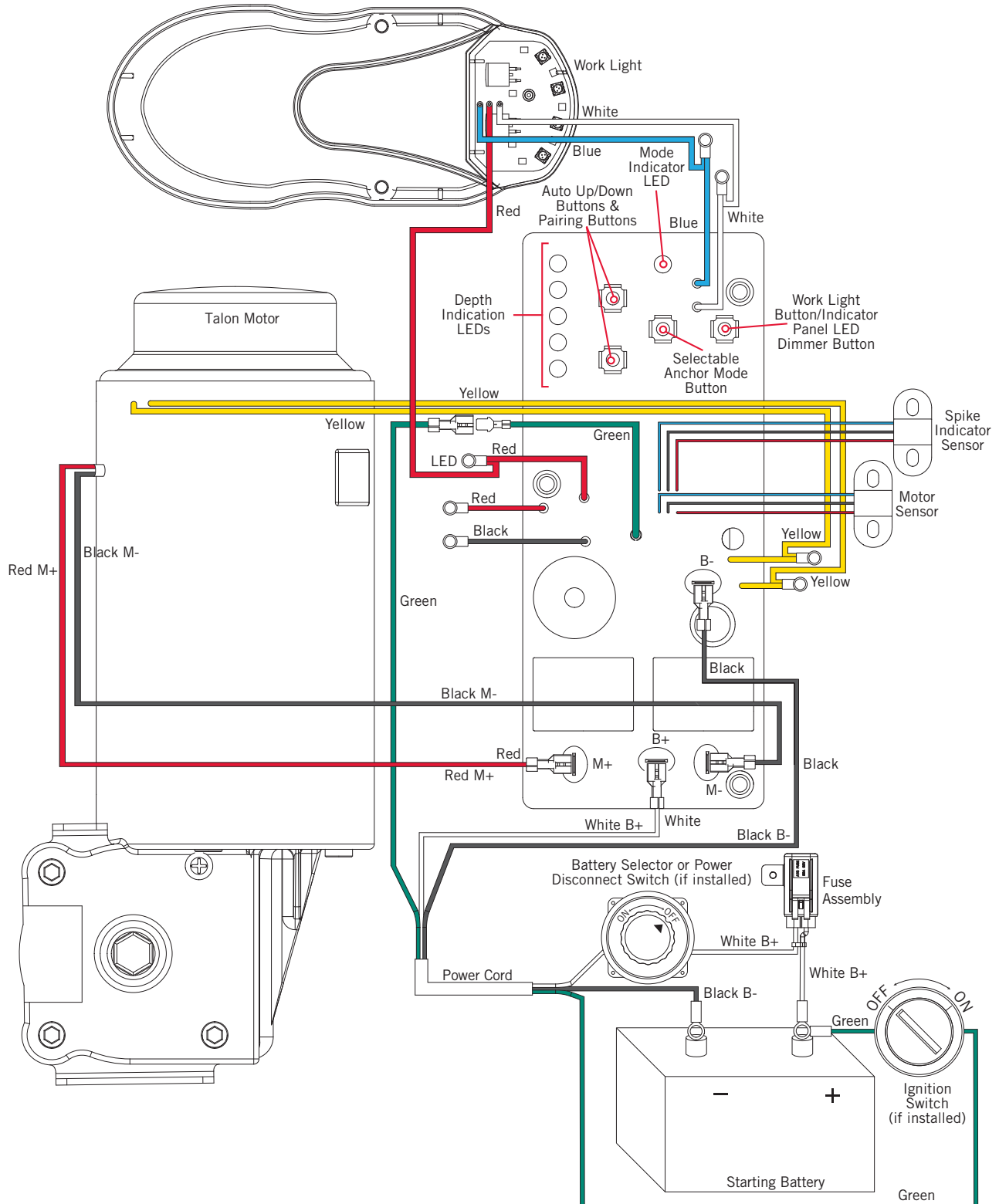

USING THE TALON

TALON FEATURES

Become familiar with the features of the Talon to maximize the capabilities this product offers.

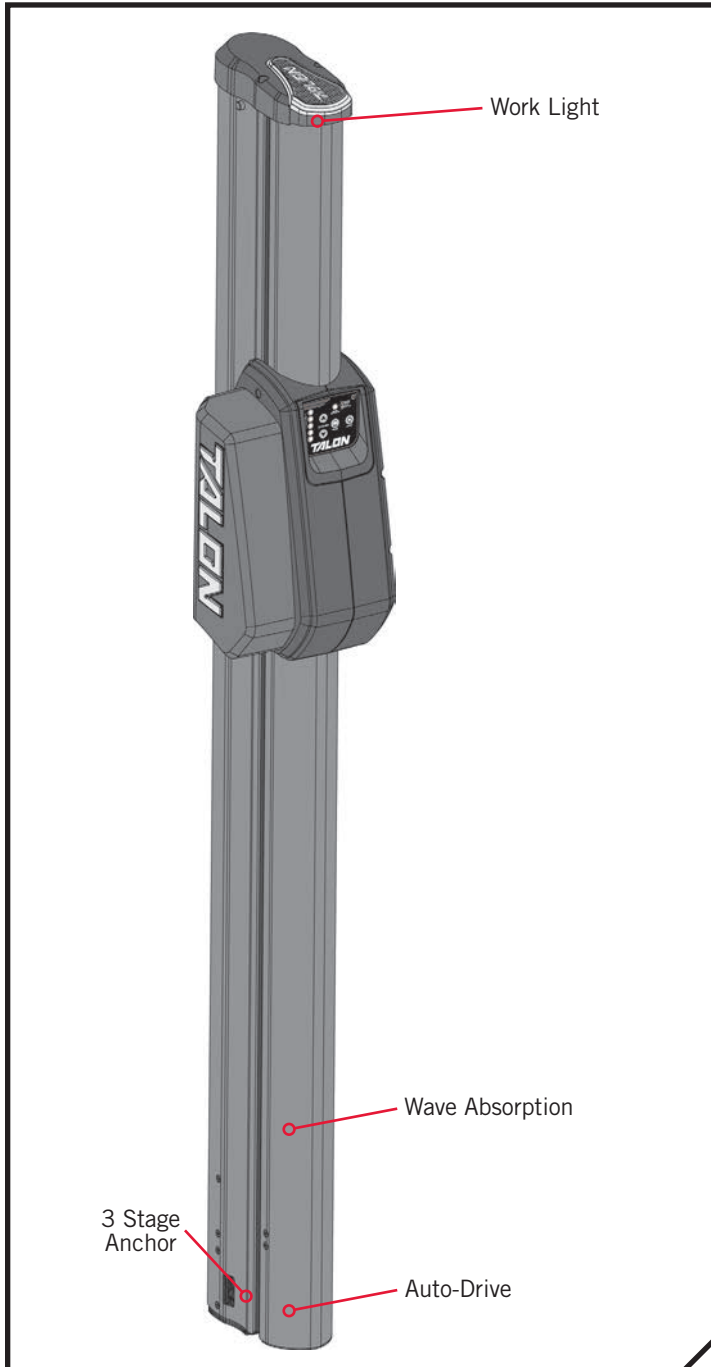

› Wave Absorption

With wave absorption, Talon enables your boat to move up or down without affecting the deployed anchor. It uses a built-in floating suspension to keep your boat anchored to the bottom, even in rough water conditions.

› 3-Stage Anchor

Your Talon Anchor works in 3 stages so you can anchor in deeper depths. The first stage of the anchor is designed with a spike for precision anchoring.

› Work Light

Talon is equipped with a work accessory light. When needed it is an easy to use, hands free light that can be toggled in intensity and color to provide adequate lighting based on your need. The Work Light can be operated from the Indicator Panel and the Remote.

› Auto-Drive

In select Modes, Auto-Drive will automatically power the Spike into the bottom with three successive hits, using increasing force on each hit. Talon actually drives the anchor in for you to ensure the anchor is seated. Talon's Auto-Drive stops driving the Spike when the Spike contacts the bottom.



NOTICE: Attempting to retract the Talon before it has completed its automated deployment sequence, will only cancel the deployment sequence in process, and not retract the Talon. You may retract the Talon normally when a deployment sequence has been completed or canceled.

TALON FEATURES

› Depth Indication LEDs

The Depth Indication LEDs display the depth that the anchor is deployed in 20% increments. Each Depth Indication LED will flash while moving through its depth percentage, and turn solid when that depth percentage is passed.

The first Depth Indication LED will flash blue as soon as the Talon is deployed. If the anchor stops for any reason while it is in the top 20% of the deployment sequence, the top LED will stay solid. The top Depth Indication LED will always illuminate to a solid color if the Talon is not fully retracted.

The bottom Depth Indication LED will only illuminate solid when the Talon has reached 100% deployment.

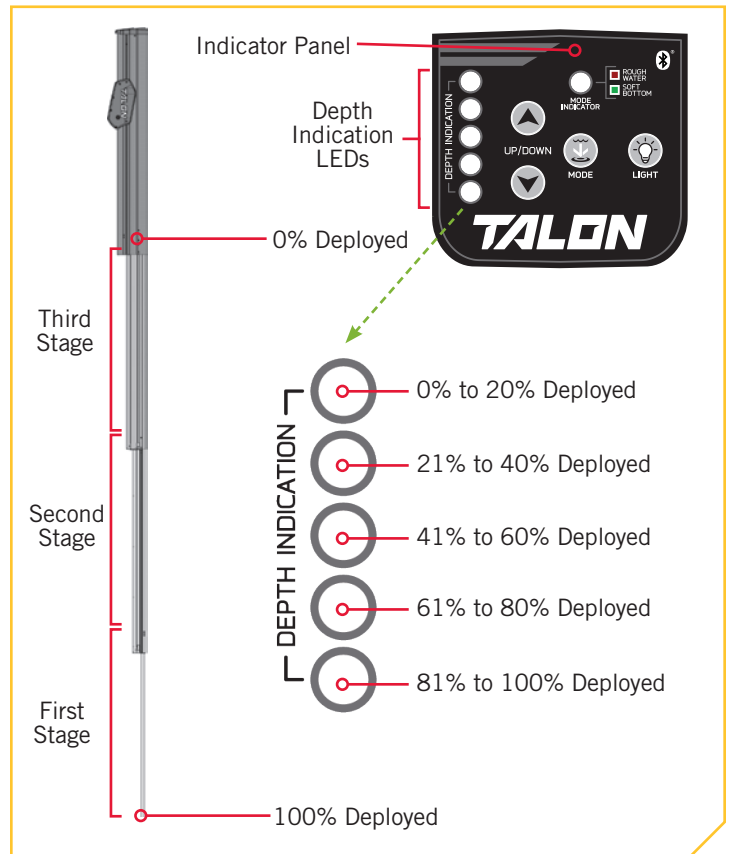

Mode Functions

The Talon operates in three different modes. Each Mode is designed for a specific on water scenario and changes the anchoring behavior of the Talon when it deploys. Talon is capable of anchoring in most conditions and it is important to select the right anchoring mode. The three different Mode functions are:

1. **Standard Mode** - Standard Mode is the default anchoring Mode for Talon. When put in Standard Mode, the Mode Indicator LED in the Indicator Panel will toggle between red and green and then turn off. In Standard Mode, Talon's Auto Deploy will operate with maximum down-force with a complete Auto-Drive cycle of three hits spaced at three seconds apart.

NOTICE: During calm conditions or on water with muddy or soft sandy bottoms, Soft Bottom Mode will prevent the Talon from over-anchoring.

2. **Soft Bottom Mode** - In Soft Bottom Mode, the Mode Indicator LED will be lit green on the Indicator Panel. In Soft Bottom Mode, the Auto Deploy will operate at a reduced power with a single hit.

NOTICE: If power is cycled to the Talon, the Talon will "remember" if it was last in "Standard Mode" or "Soft Bottom Mode," and will return to that last known mode. However, if it is left in "Rough Water Mode," and power is cycled, it will default to "Standard Mode." This is done to prevent Talon from unnecessarily over-anchoring.

3. **Rough Water Mode** - In Rough Water Mode, the Mode LED Indicator on the Indicator Panel will be lit red. In Rough Water Mode, the Auto Deploy will operate with maximum down-force with three Auto-Drive cycles of three hits each, spaced 3 seconds apart. **The three Auto-Drive cycles will be spaced at 10 second intervals.**

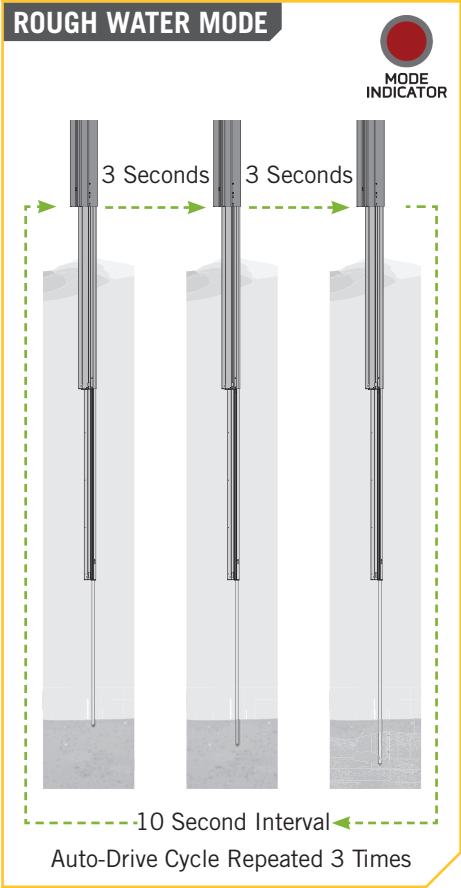

CONTROLLING THE TALON WITH THE INDICATOR PANEL



CONTROLLING THE TALON WITH THE INDICATOR PANEL >

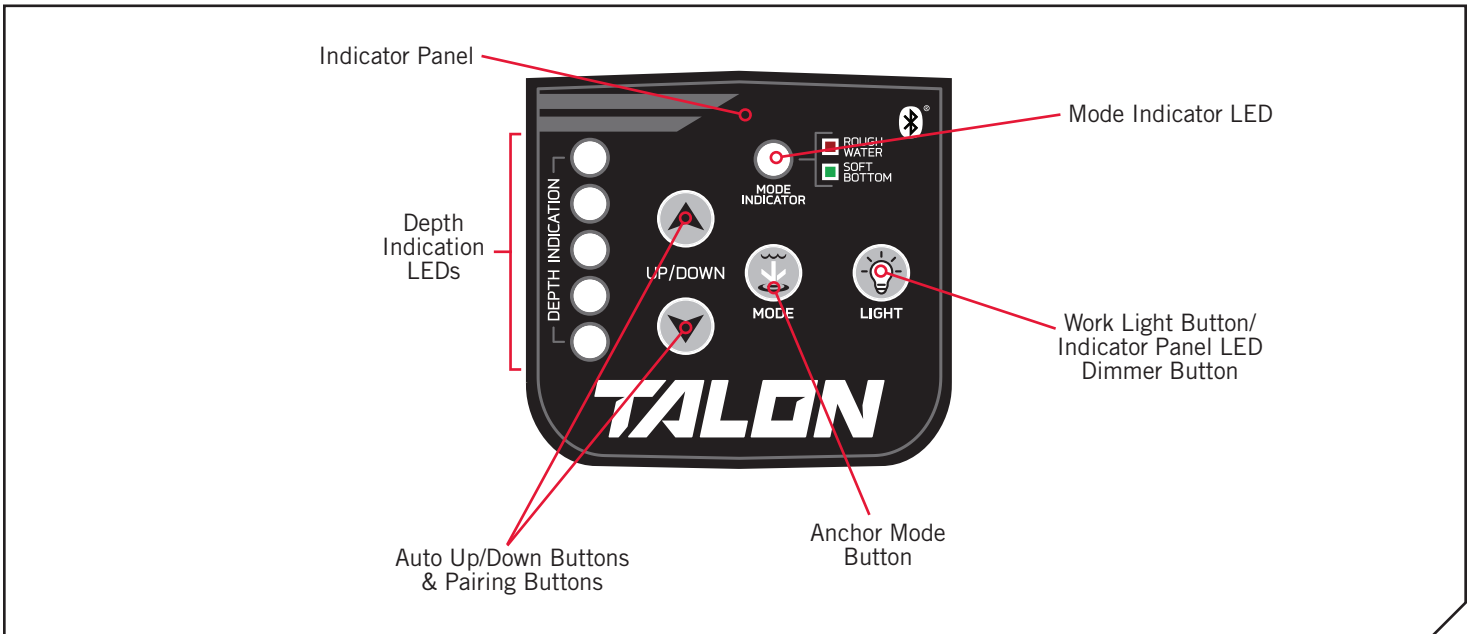

Depth Indication LEDs

LEDs that indicate the depth that the Talon is deployed, paused or retracted at. Each LED represents 20% increments.

Auto Up / Down Buttons / Pairing Buttons

Used to deploy, retract or pause the anchor on the Talon. Used to pair the Talon to a variety of remotes and devices, or other Talons via Bluetooth.

Anchor Mode Button

Used to select between Standard Mode, Soft Bottom Mode and Rough Water Mode. Also referred to as the Mode button.

Work Light Button/ Indicator Panel LED Dimmer Button

Used to toggle the Work Light "on" and "off" and switch between the different Work Light colors and intensities. Also used to change the intensities of the Depth Indication LEDs and the Mode Indicator LED on the Indicator Panel. Also referred to as the Light Button.





Mode Indicator

LED is not lit with Standard Mode, is lit green in Soft Bottom Mode and is lit red in Rough Water Mode.

CONTROLLING THE TALON WITH THE INDICATOR PANEL

› Deploy the Talon from the Indicator Panel

Use the buttons on the Indicator Panel to deploy the Talon anchor.

- 1**
 - a. To deploy the Talon, press the Down  button on the Indicator Panel.
 - b. While the anchor is deploying, the action can be paused on the panel by either pressing the Down  button again, or pressing the Up  button.
 - c. The paused deployment can be resumed by pressing the Down  button again.
 - d. Once the deploying anchor gets to its full length of travel or comes in contact with the bottom, it will go through an anchoring sequence determined by the current Mode and then stop.

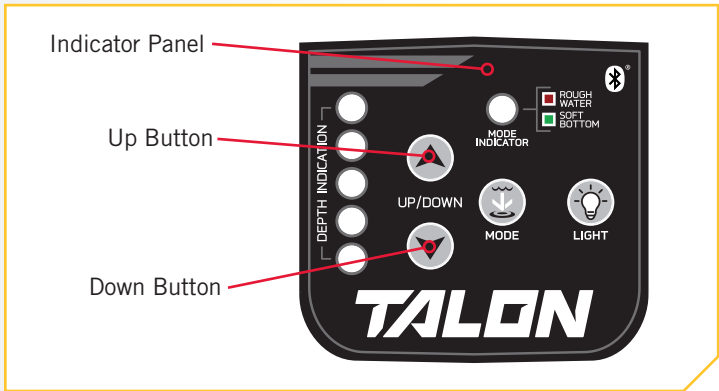

NOTICE: When two Talons are paired, to control a Talon individually it must be deployed from its own Indicator Panel.

NOTICE: You do not need to press and hold the button to keep the Talon deploying. The Talon will automatically continue to deploy when the button is pressed until it has reached its full deployment length, received input to stop or completes anchoring.

NOTICE: The Depth Indication LEDs display the depth that the anchor is deployed in 20% increments. Each Depth Indication LED will flash while moving through it's depth percentage, and turn solid when that depth percentage is passed. The first Depth Indication LED will flash blue as soon as the Talon is deployed. If the anchor stops for any reason while it is in the top 20% of the deployment sequence, the top LED will stay solid. The top Depth Indication LED will always illuminate to a solid color if the Talon is not fully retracted. The bottom Depth Indication LED will only illuminate solid when the Talon has reached 100% deployment.

WARNING

Take care that neither you nor other persons approach the Talon too closely, while operating, neither with body parts nor with objects. The Talon is powerful and may endanger or injure you or others. While the Talon is operating, watch out for persons swimming and for floating objects. Persons who lack the ability to run the Talon or whose reactions are impaired by alcohol, drugs, medication, or other substances are not permitted to use this product.

CAUTION

The Talon is equipped with a Deployment Notification Alarm. The Alarm is needed to comply with warranty requirements and when properly installed the alarm will only sound when the ignition key is turned on when the Talon is not fully retracted. Boat control may be affected by a deployed Talon. Take note of the Alarm, and always watch to make sure that the Talon is fully retracted while the boat is operating.

CONTROLLING THE TALON WITH THE INDICATOR PANEL

› Retracting the Talon from the Indicator Panel

Use the buttons on the Indicator Panel to retract the Talon anchor.

- 1
 - a. To retract the Talon, press the Up ▲ button on the Indicator Panel.
 - b. While the anchor is retracting, the action can be paused on the panel by either pressing the Up ▲ button again, or pressing the Down ▼ button.
 - c. The paused retraction can be resumed by pressing the Up ▲ button again.
 - d. Once the retracting anchor on the Talon gets to its fully retracted state, it will stop. If the Talon is already fully retracted and the Up ▲ button is pressed again, an error tone will sound.

NOTICE: To retract a specific Talon, when two Talons are paired, the anchor of the Talon where the Indicator Panel is pressed will retract.

⚠ CAUTION

Be sure that the Talon is clear of obstructions and persons while retracting. The spaces between the 3 stages of the Talons can create a pinch point. Do not come in contact with the Talon while it is retracting to avoid the pinch point.

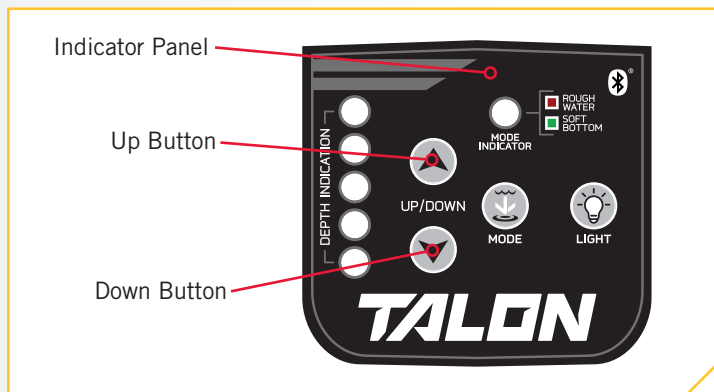



NOTICE: You do not need to press and hold the button to keep the anchor retracting. The Talon will automatically continue to retract when the button is pressed until the Talon is either fully retracted or receives input to stop.

NOTICE: The blue LED's on the Indicator Panel are a visual reference relaying the current depth of the Talon anchor. Read the "Using the Talon" section of this manual to learn how the LED display works.

CONTROLLING THE TALON WITH THE INDICATOR PANEL

Toggle the Mode from the Indicator Panel

Toggle the Mode on the Indicator Panel when the water or anchoring conditions change to fit your anchoring needs.

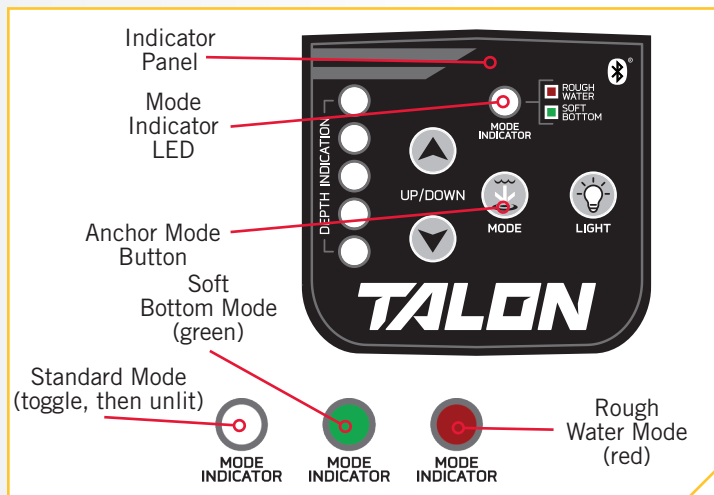

- 1 a. The Mode can be toggled from the Indicator Panel by selecting the Mode  button. The Mode Indicator LED displays the Mode that the Talon is currently set to. Press the Mode  button to toggle to the desired Mode.
- b. When no color is present on the LED, the Talon is in Standard Mode. When the LED is Green, the Talon is in Soft Bottom Mode. When the LED is Red, the Talon is in Rough Water Mode.

NOTICE: When the Talon is paired with a second Talon, pressing the Mode Button on the Talon will toggle the Mode for both Talons. Read the "Using the Talon" section of this manual to learn more about Modes.



Toggle the Work Light "on" and "off" with the Indicator Panel

The Work Light is an accessory light at the top of the Talon. When the Work Light is turned "on", the LEDs can be either white or blue.

- 1 a. To Toggle the Work Light "on", press the Light  button on the Indicator Panel. To toggle the Work Light "off" wait 5 seconds and press the Light  button again.

NOTICE: When the Talon is paired with a second Talon, pressing the Light  button on the Talon will toggle the light for both Talons.

WARNING

The Work Light on the Talon is not intended for navigational purposes. The Work Light does not replace or act as a substitute for proper navigation lighting of your vessel. Failure to properly light your boat may cause harm or serious injury.

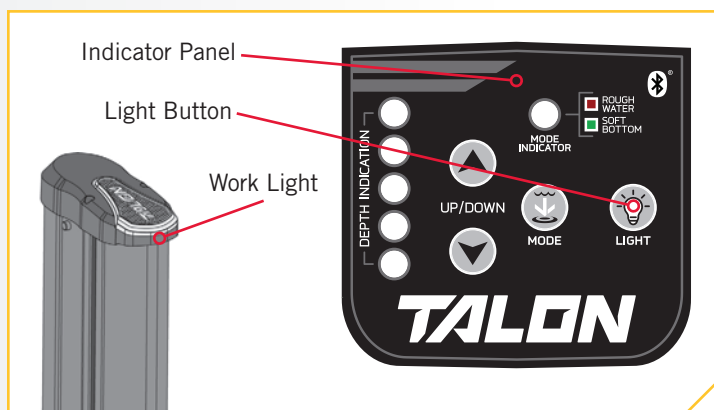



CONTROLLING THE TALON WITH THE INDICATOR PANEL

› Toggle the Work Light Color and Intensity on the Indicator Panel

The Work Light on the Talon has a high - medium - low intensity setting of white LEDs and blue LEDs. When the Work Light is turned on, the LEDs will be either white or blue, and then an intensity setting can be selected.

1

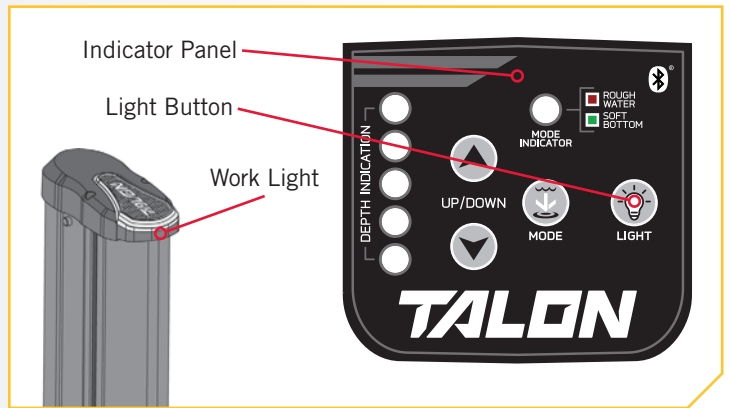

- a. When the Work Light is "off", press the Light  button once on the Indicator Panel to turn the light "on". The light will turn on with the last light intensity and color selection that was used.
- b. If the Light  button is pressed again in less than 5 seconds, the lights will move to the next intensity and/or color. Continue to press the Light  button until the desired light is selected. If more than 5 seconds passes between any button press, the current color and setting will be "saved" to memory, and the Work Light will turn "off" instead of toggling to the next selection.



› Change the Intensity of the LEDs in the Indicator Panel

The Indicator Panel LEDs, by default, are at the brightest setting. It is possible to change the intensity of the LEDs to meet personal preference or adjust them to fit the ambient lighting conditions. The LED's can toggle between three intensities; high, medium and low.

1

- a. Press and hold the Light  button for 2 seconds.
- b. Continuing to hold the Light  button will cause the Indicator Panel LEDs to begin toggling through 3 different intensities of high, medium, and low. Release the Light  button once you have achieved the desired intensity.

NOTICE: Using the Light  button on the Indicator Panel is the only way to change the intensity of the LEDs in the panel. The LEDs are programmed from the factory to be at the highest intensity by default.

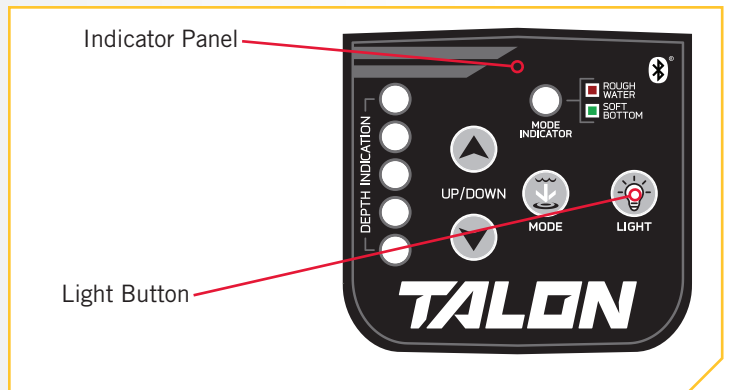

CONTROLLING THE TALON WITH THE REMOTE

CONTROLLING THE TALON WITH THE REMOTE >

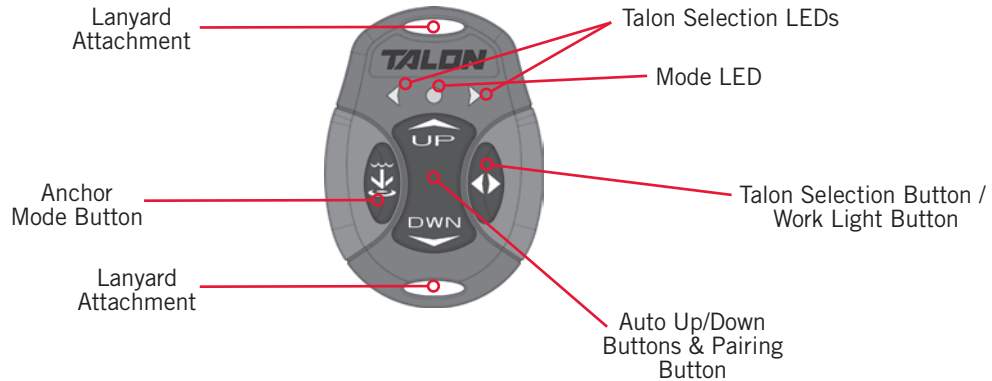

Anchor Mode Button

Used to select between Standard Mode, Soft Bottom Mode and Rough Water Mode.



Auto Up/Down Buttons & Pairing Buttons

Used to deploy, retract or pause the anchor on the Talon. Also used to pair the Remote to a Talon.



Talon Selection Button / Work Light Button

Used to select the Port, Starboard, or both Talons. Used to toggle the Work Light "on" and "off" and switch between the different Work Light colors and intensities.



Talon Selection LEDs

When 2 Talons are paired in the system, the right LED is lit when the Starboard Talon is selected and the left LED is lit when the Port Talon is selected. Both the right and left arrows are lit when both Talons are selected. When only one Talon is paired, the lights will toggle, but the selection will control the only paired Talon. When a selection is made, the LEDs will stay lit for 1 second and then turn off.



Mode Selection LEDs

The Center LED flashes red and green and then turns off for Standard Mode. The center LED will be lit green for Soft Bottom Mode and lit red for Rough Water Mode. When in Soft Bottom Mode and Rough Water Mode, the LED will stay lit for 1 second and then turn off.

CAUTION

Never leave the boat unattended with the Talon as your only boat anchor. Talon is not intended to provide primary anchorage. This includes operating the remote at a safe distance. It is not recommended to leave the boat while operating the Talon with the remote. Doing so is at the owner's risk. This product does not relieve you from the responsibility of safe operation of your boat.

CONTROLLING THE TALON WITH THE REMOTE

› Selecting a Talon to Operate with the Remote

The Talon Selection  button toggles the Talon that the remote is controlling, when 2 Talons are installed on the boat. The selection toggles between a Talon mounted on the Port or Starboard side of the boat, or it can control both Talons at the same time. The Talon Selection LED's are lit based on the selection made.

1

- a. To toggle the Talon selected, press the Talon Selection  button, repeatedly until the desired Talon is selected.
- b. When the button is pressed, one or both of the Talon Selection LEDs will be lit. If the remote is oriented so the LEDs are facing upward, the arrow on the right will be lit when the Starboard Talon is selected. If the arrow on the left is lit, the Port Talon is selected. If the LED in both arrows is lit, both Talons are selected.

NOTICE: When two Talons are paired to the remote, the anchors may not be in sync when retracting and deploying.

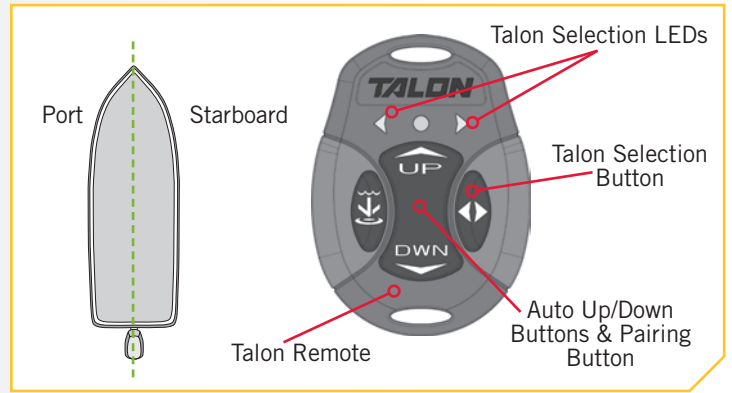





NOTICE: The Talon Remote will always remember the last selection made unless the remote or Talon lose power.

CONTROLLING THE TALON WITH THE REMOTE

› Deploy the Talon from the Remote

Use the buttons on the Remote to deploy the Talon anchor.

1

- a. To deploy the Talon, double press the Down  button on the Remote.
- b. While the anchor is deploying, the action can be paused on the remote by pressing either the Down  button or Up  button again.
- c. The paused deployment can be resumed by double pressing the Down  button again.
- d. Once the deploying anchor gets to its full length of travel or comes in contact with the bottom, it will go through an anchoring sequence determined by the current Mode and then stop.

NOTICE: When two Talons are paired, the anchor of the selected Talon will deploy. The selection can be Port, Starboard, or both.

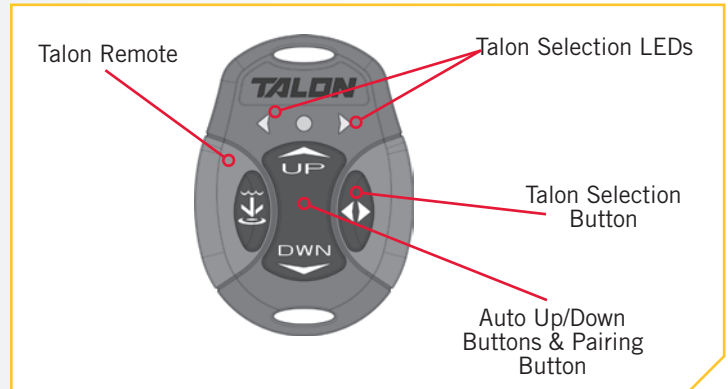

NOTICE: You do not need to hold the button to keep the Talon deploying. The Talon will automatically continue to deploy when the button is double pressed until it has reached its full deployment, received input to stop or anchors.

NOTICE: The Depth Indication LEDs display the depth that the anchor is deployed in 20% increments. Each Depth Indication LED will flash while moving through it's depth percentage, and turn solid when that depth percentage is passed. The first Depth Indication LED will flash blue as soon as the Talon is deployed. If the anchor stops for any reason while it is in the top 20% of the deployment sequence, the top LED will stay solid. The top Depth Indication LED will always illuminate to a solid color if the Talon is not fully retracted. The bottom Depth Indication LED will only illuminate solid when the Talon has reached 100% deployment.

WARNING

Take care that neither you nor other persons approach the Talon too closely, while operating, neither with body parts nor with objects. The Talon is powerful and may endanger or injure you or others. While the Talon is operating, watch out for persons swimming and for floating objects. Persons who lack the ability to run the Talon or whose reactions are impaired by alcohol, drugs, medication, or other substances are not permitted to use this product.





CAUTION

The Talon is equipped with a Deployment Notification Alarm. The Alarm is needed to comply with warranty requirements and when properly installed the alarm will only sound when the ignition key is turned on when the Talon is not fully retracted. Boat control may be affected by a deployed Talon. Take note of the Alarm, and always watch to make sure that the Talon is fully retracted while the boat is operating.

CONTROLLING THE TALON WITH THE REMOTE

› Retracting the Talon from the Remote

Use the buttons on the Remote to retract the Talon anchor.

- 1**
 - a. To retract the Talon, press the Up  button on the Remote.
 - b. While the anchor is retracting, the action can be paused on the remote by pressing either the Up  button or the Down  button.
 - c. The paused retraction can be resumed by pressing the Up  button again.
 - d. Once the retracting anchor on the Talon gets to its full retraction it will stop. If the Talon is already fully retracted and the Up  button is pressed again, an error tone will sound.

NOTICE: When two Talons are paired, the anchor of the Talon selected on the Remote will retract. The selection can be Port, Starboard, or both.

CAUTION

Be sure that the Talon is clear of obstructions and persons while retracting. The spaces between the 3 stages of the Talons can create a pinch point. Do not come in contact with the Talon while it is retracting to avoid the pinch point.

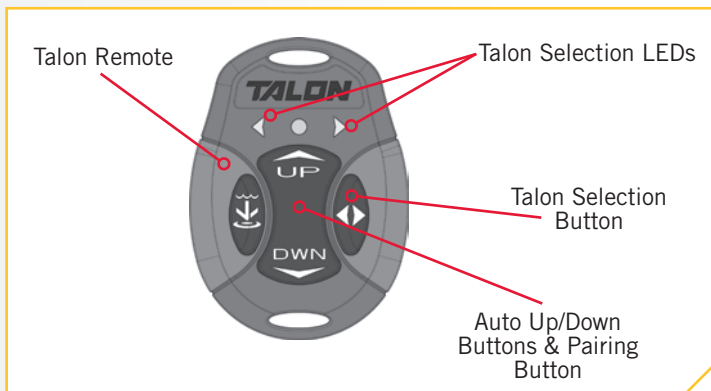

NOTICE: You do not need to press and hold the button to keep the anchor retracting. The Talon will automatically continue to retract when the button is pressed until the Talon is either fully retracted or receives input to stop.



NOTICE: The blue LEDs on the Indicator Panel are a visual reference relaying the current depth of the Talon anchor. Read the "Using the Talon" section of this manual to learn how the LED display works.

CONTROLLING THE TALON WITH THE REMOTE

› Toggle the Mode from the Remote

Toggle the Mode on the Remote when the water or anchoring conditions change to fit your anchoring needs.

1

- The Mode can be toggled from the Remote by selecting the Anchor Mode  button. The Mode LED displays the Mode that the Talon is currently set to. Press the Anchor Mode  button to toggle to the desired Mode.
- When the Talon is put in Standard mode, the LED will flash red and green and then turn off. When the LED is Green, the Talon is in Soft Bottom Mode. When the LED is Red, the Talon is in Rough Water Mode.

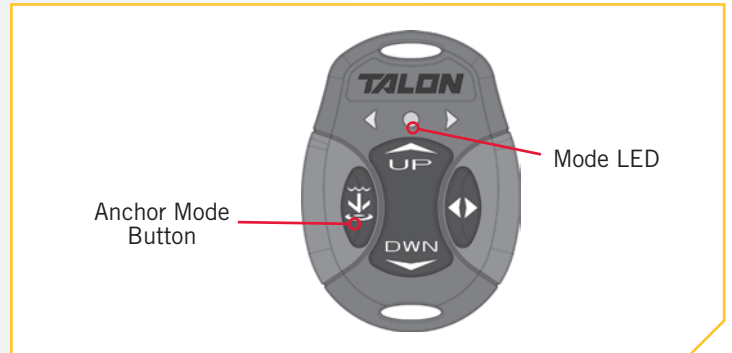

NOTICE: When the Talon is paired with a second Talon, pressing the Anchor Mode  button on the Talon will toggle the Mode for both Talons. Read the "Using the Talon" section of this manual to learn more about Modes.



› Control the Work Light with the Remote

The Work Light at the top of the Talon can be either white or blue and toggled between high, medium, or low intensities.

1

- To Toggle the Work Light "on", press and hold the Talon Selection  button until the Work Light on the top of the Talon turns "on".
- Continue to press the Talon Selection  button on the Remote again before 5 seconds passes until the desired color and intensity is selected.
- To toggle the Work Light "off" press and hold the Talon Selection  button again until the Work Light turns "off".

NOTICE: When the Talon is paired with a second Talon, pressing and holding the Talon Selection  button will toggle the light for both Talons. The six intensities for the Work Light are white high, white medium, white low, blue high, blue medium and blue low.

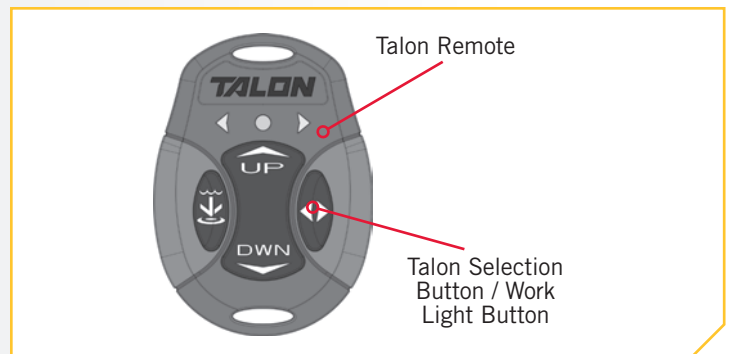

WARNING

The Work Light on the Talon is not intended for navigational purposes. The Work Light does not replace or act as a substitute for proper navigation lighting of your vessel. Failure to properly light your boat may cause harm or serious injury.

SERVICE & MAINTENANCE

⚠ CAUTION

Before beginning any maintenance work, disconnect the Talon from the battery or if connected to a battery selector switch or power disconnect switch, make sure that it is turned to the "off" position. Failure to disconnect power during maintenance work may result in shock, unexpected operation and/or injury. Minn Kota recommends having the Talon serviced by an qualified marine technician at an Authorized Service Center.

REPLACING THE REMOTE BATTERY

TOOLS AND RESOURCES REQUIRED >

- Large Coin

INSTALLATION >

- 1 a. Make sure your hands are clean, dry and static free. Temporarily ground yourself by touching a grounded metal object in order to discharge any static electricity in your body.

⚠ CAUTION

Static electricity can cause damage to the circuit board. Discharge any static electricity by touching a metal object that is grounded before beginning the remote battery replacement.

- b. With the back of the Remote facing you, use a large coin to rotate the Battery Cover counterclockwise until either of the Unlock Icons align with the Arrow.

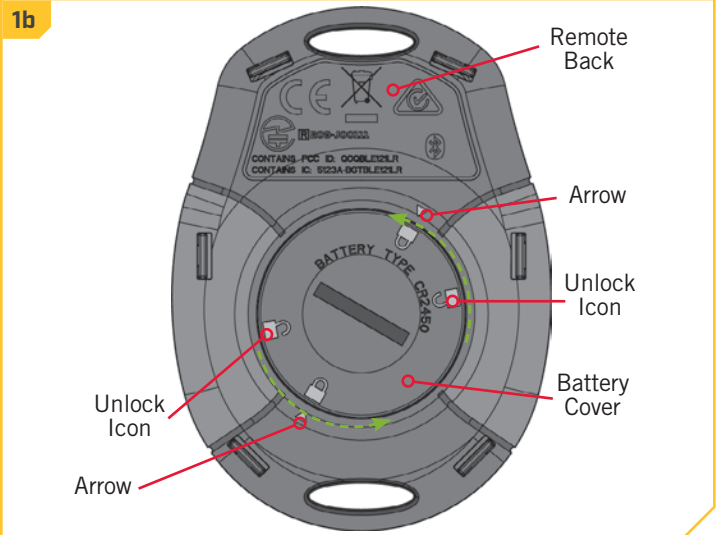

REPLACING THE BATTERY

2

- c. Remove the Battery Cover and old battery and replace with a new CR2450 coin cell battery. Note the proper polarity of the battery.

NOTICE: The replacement battery must be a model CR2450 coin cell type. It is strongly recommended that a high quality battery is used. The positive (+) of the battery should be facing towards the Battery Cover.

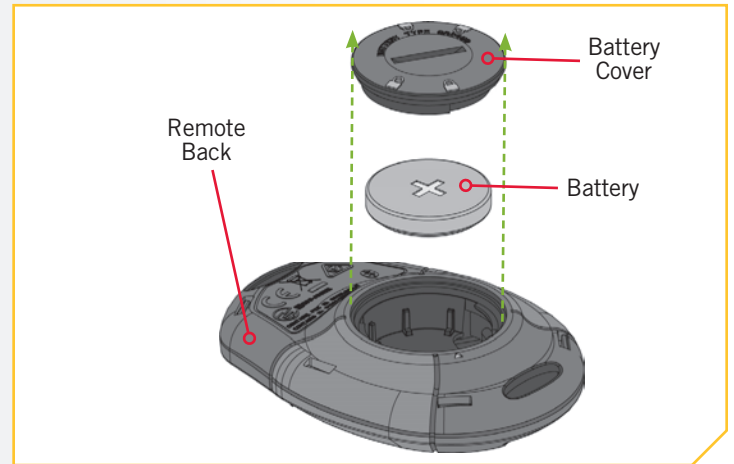

3

- d. Ensure the rubber O-ring is properly seated in the underside of the Battery Cover. Replace battery cover by aligning either of the Unlock icons with the arrow, and pressing the cover down.
- e. Rotate the Battery Cover clockwise using the large coin until the Lock Icon aligns with the Arrow.

3d

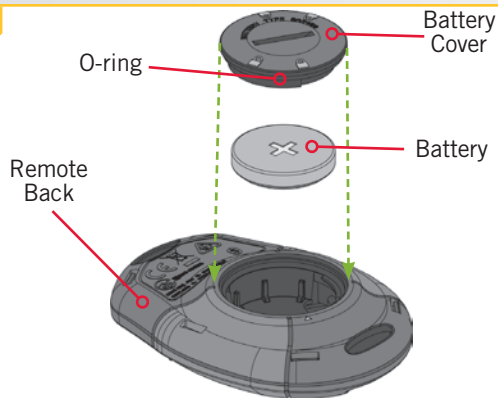



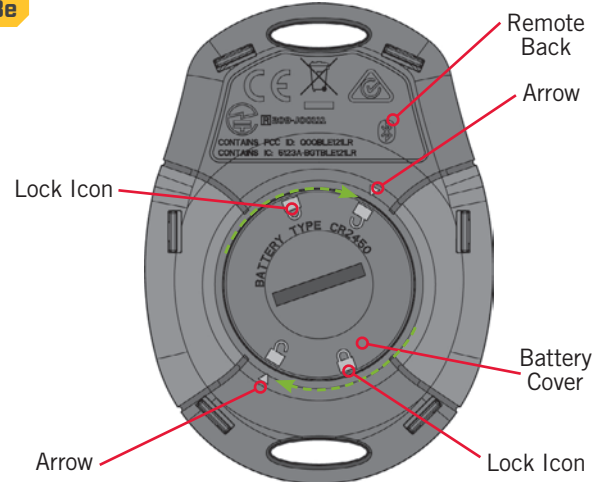

3e



PAIRING A REMOTE TO A SINGLE TALON

PAIRING A REMOTE TO A SINGLE TALON

Every Talon comes direct from the factory with 2 remotes already paired to the Talon. However, any Talon can be paired with up to 3 devices per Talon.

- 1**
 - a. Retract the anchor on the Talon by pressing the Up  button.
 - b. Once the Talon is fully retracted, press and hold the Up  button and the Down  button on the Remote at the same time until the Talon Selection LEDs on the Remote begin to scroll. Then release them.
 - c. Immediately press and hold the Up  button and the Down  button simultaneously on the Indicator Panel. The Depth Indication LEDs will begin to flash blue. Once the LEDs are flashing release the buttons on the Indicator Panel. The Talon and Remote will go into Pairing Mode for 20 seconds. If a signal with three fast beeps occurs, the Talon and Remote have successfully paired. If 20 seconds pass while in Pairing Mode and they do not successfully pair, a chirp will sound signaling that the Pairing has timed out.
 - d. If the Pair is unsuccessful, repeat the process.





PAIRING TWO TALONS AND PROGRAMMING THE MOUNTING LOCATION

PAIRING TWO TALONS AND PROGRAMMING THE MOUNTING LOCATION

Every Talon comes direct from the factory with 2 remotes already paired to the Talon. However, any Talon can be paired with up to 3 devices per Talon. When a boat has two Bluetooth enabled Talons installed, it is necessary to pair both Talons together, and to program which side of the boat each Talon is installed on. The process below is used to pair the Talons together, and to designate which side of the boat the each Talon is installed on. When the process is complete, all remotes that were paired to an individual Talon will now operate both Talons. If not, please see the "Pairing a remote to two Talons" section of this manual. Adding more than 3 devices per Talon may affect communication within the Bluetooth network.

1

- a. Retract the anchor on both Talons by pressing the Up  button on each Talon.
- b. Once both Talons are fully retracted, press and hold the Up  button and the Down  button on the Indicator Panel of one Talon. Once the Depth Indication LEDs on the Indicator Panel begins to flash blue, release the buttons. Immediately follow this step on the second Talon.
- c. Once the buttons are released, the Talons are in Pairing Mode and will search for each other for 20 seconds. If they do not Pair after 20 seconds, an error tone will sound signaling that the Pairing has timed out. If this occurs, double check that the Talons are fully retracted and start the process again.
- d. If the Talons successfully Pair, a confirmation tone with three fast beeps will occur. At this point, the Talons have successfully paired, and now need to be programmed to designate the Port or Starboard locations.

1a



1b

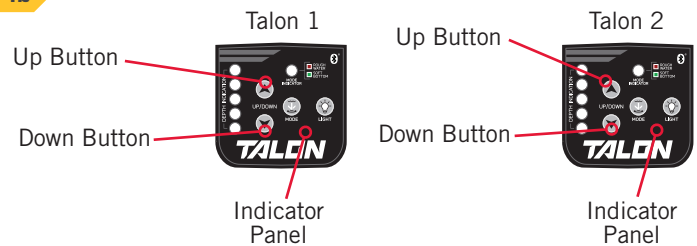

2

NOTICE: This process will automatically begin when two Talons have successfully paired to each other.

- e. The Mode Indicator LED will turn green on both Talons. On the Indicator Panel of the Starboard Talon, press the Up  button. The Talon will accept the selection. The Talon on the Port side will flash red and then the LEDs on both Talons will turn off. Now the Talons are successfully Paired together and know their mounted position.



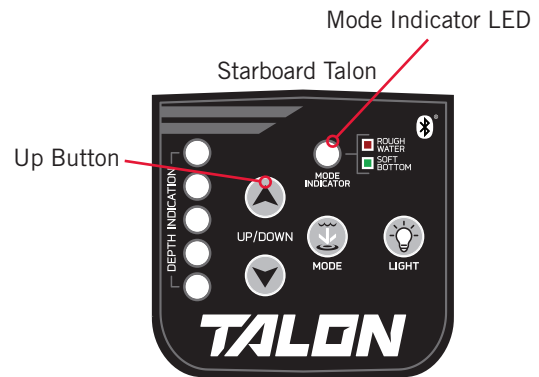

1e



PAIRING A REMOTE TO TWO TALONS

PAIRING A REMOTE TO TWO TALONS

In order to Pair a remote to the Talon, please be sure to first Pair the Talons together. When two Bluetooth Talons are paired together, all remotes that were paired to an individual Talon will operate both Talons. Please see the "Pairing Two Talons and Programming the Mounting Location" section of this manual. If the two Talons are already paired together, a remote can be paired to either Talon. When the pairing process is complete, the remote will be able to control both Talons.

- 1**
 - a. Retract the anchor on both Talons by pressing the Up  button.
 - b. Once both Talons are fully retracted, press and hold the Up  button and the Down  button on the Remote at the same time until the Talon Selection LEDs on the Remote begin to scroll. After 2 seconds, release the buttons.
 - c. Immediately press and hold the Up  button and the Down  button simultaneously on the Indicator Panel of one Talon. The Depth Indication LEDs will begin to flash blue on both Talons. Once the LEDs are flashing release the buttons on the Indicator Panel. The Talon and Remote will go into Pairing Mode for 20 seconds.
 - d. If a tone with three fast beeps occurs, the Talon and Remote have successfully paired. If 20 seconds pass while in Pairing Mode and they do not successfully pair, an error tone will sound signaling that the Pairing has timed out.
 - e. If the Pair is unsuccessful, repeat the process.

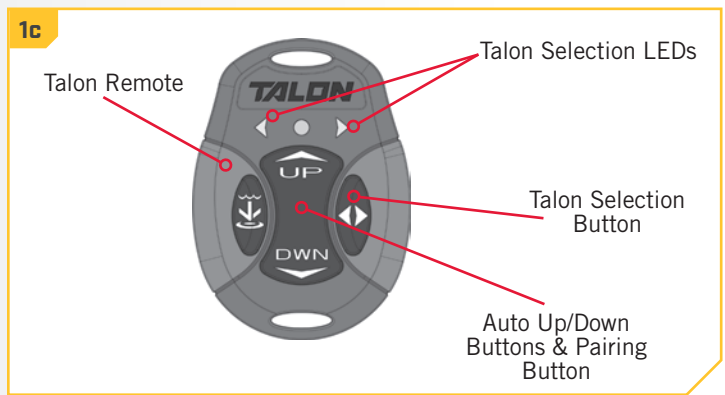
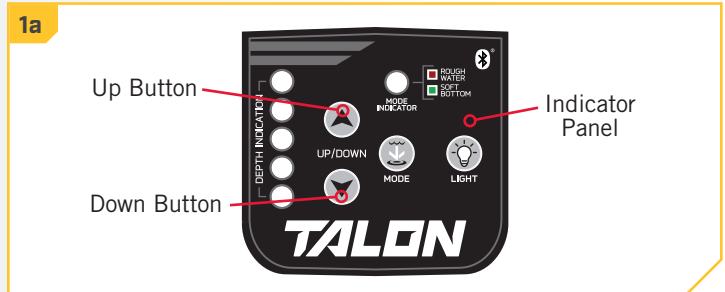

CLEARING PAIRED REMOTES OR DEVICES FROM THE TALON

The Talon was designed so that all paired devices can be cleared from memory.

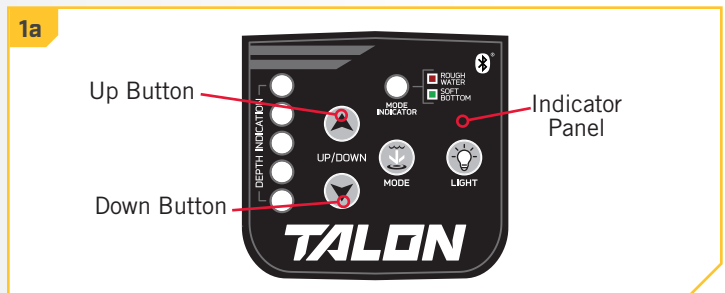

- 1**
 - a. Retract the anchor on the Talon by pressing the Up  button.
 - b. Turn the power to the Talon "off".



CLEARING PAIRED REMOTES OR DEVICES FROM THE TALON

2

NOTICE: This may require assistance from another person.

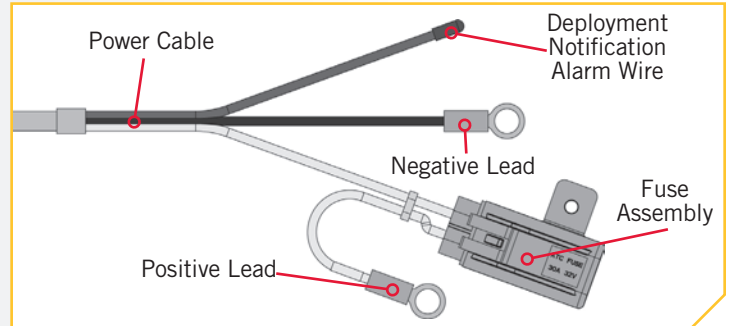

- c. While holding in the Up  button on the Indicator Panel, restore power to the Talon. A series of fast beeps will be heard followed by a long steady tone.
- d. After the steady tone stops, release the Up  button.



CLEARING PAIRED TALONS FROM THE REMOTE

The Remote was designed so that all paired Talons can be cleared from memory.

1

- a. Press and hold the Up  button and the Down  button on the Remote at the same time until the Talon Selection LEDs on the Remote begin to scroll, release the buttons. The Remote will go into Pairing Mode for 20 seconds. Once Pairing times out all Talons will be cleared.

NOTICE: Putting the Remote into Pairing Mode, even if it is accidental, without Pairing the Remote to a Talon will clear all paired Talons.

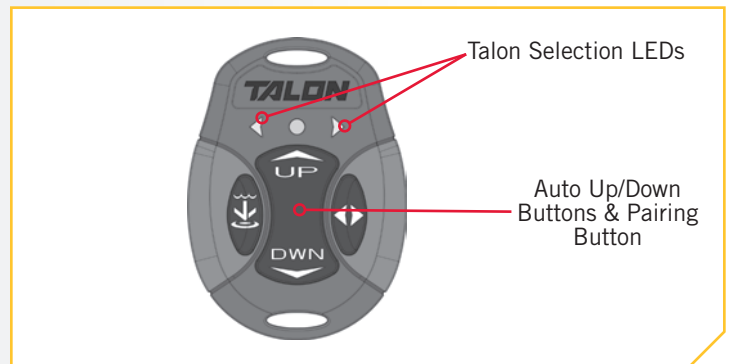

MANUALLY RETRACT THE TALON

In the event that you ever need to manually retract the Talon, follow the procedure below.

NOTICE: The Talon would need to be in a deployed state when the Manual Retraction Procedure is used.

1

- a. Press and hold the Up  button on the Indicator Panel until you hear 3 successive beeps. This will put the Talon in Manual Retraction Mode.
- b. Remove the Rubber Cap on the Manual Retraction Hex-Drive and use a 7/16" Socket Wrench, to turn the Hex-Drive in a clockwise direction.

CAUTION

The Talon may become slippery when wet. Be careful not to not slip and fall when adjusting the Manual Retraction Hex-Drive.

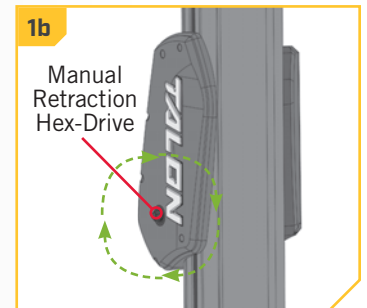

THE RETRACTION NOTIFICATION ALARM

2

- c. Continue to turn the Hex-Drive in a clockwise direction until the Talon is fully retracted. Visually confirm that the Spike is fully retracted.
- d. Once retracted, the Talon must be taken out of Manual Retraction Mode. Manual Retraction mode will time-out after 30 minutes, or press and release the Up  button on the Indicator Panel. Three successive beeps will sound. This tone will confirm that the Talon has exited Manual Mode.

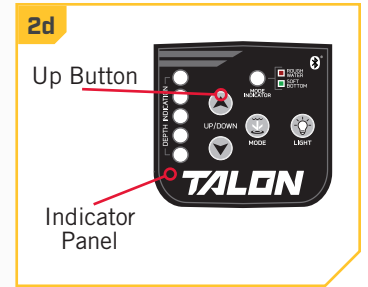
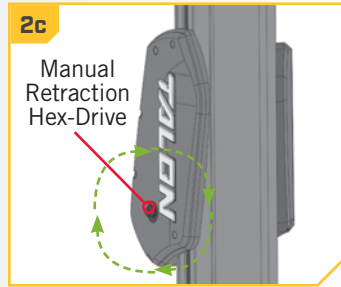

NOTICE: Once the Talon is put into Manual Retraction Mode, it will stay in this mode for 30 minutes.



THE RETRACTION NOTIFICATION ALARM

The Talon is equipped with a Retraction Notification Alarm to protect the lift motor. If the lift capacity of the motor is exceeded or the motor takes more than 10 seconds to retract, the motor will stop and emit a series of three sets of three beeps. This is different from the Deployment Notification Alarm, which will emit a tone each time the ignition key is turned "on" and the anchor is not retracted. The Retraction Notification Alarm sounds when the Talon fails to retract. The most common reasons for the Retraction Notification Alarm sounding are:

1. Because of an extremely soft or muddy bottom and the Spike is deeply buried and cannot retract on its own.
2. There may be an excessive amount of side load on the Spike, generally due to fast moving water currents or wind.
3. Battery Power is low. This may create a retraction time that is greater than 10 seconds.
4. Obstructions on the anchor prevent it from retracting.

If the Retraction Notification alarm is emitted, the following steps should be taken to retract the anchor.

1

- a. Press the Up  button on the Indicator Panel or the Up  button on the Remote. If the Spike does not raise within two attempts:
- b. Loosen the Spike from the bottom by carefully driving the boat back and forth using the main engine power. Then attempt to raise the anchor again. This is especially useful if you are fishing in a soft or muddy bottom structure.
- c. Remove any excessive side loads on the anchor as described above. This generally requires re-backing against the current or the direction of the load and then attempting to retract the anchor again with the side load removed. In the event that the Spike cannot be retracted normally, please refer to the "Manually Retract the Talon" section of this manual.

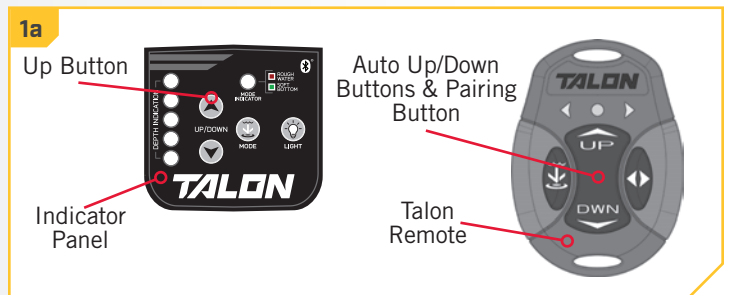

NOTICE: If this is typical for the areas where you fish, Minn Kota strongly recommends using the Soft-Bottom Mode.

RESET THE FUSE

In the event that you need to reset the factory installed 30 amp Fuse, follow the instruction below. The fuse should be located no more than 7 inches from the Positive Battery terminal on the Positive Lead (+). If an alternate Fuse is installed, please refer to directions by your Fuse manufacturer to correctly reset it.

- 1**
 - a. Remove the protective cover from the Fuse Assembly, exposing the 30 amp Fuse.
 - b. Reset the Fuse by pushing the Breaker Button to engage the Fuse.
 - c. Ensure that the Seal is in place, and replace the protective housing on the Fuse Assembly. Make sure that the Cover snaps together to provide a watertight seal.

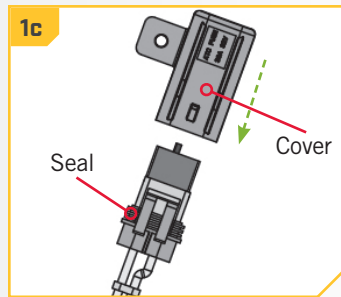
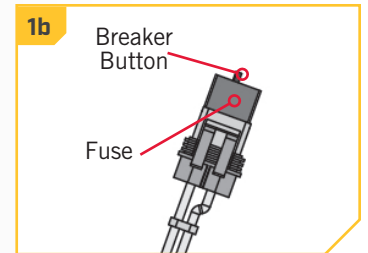
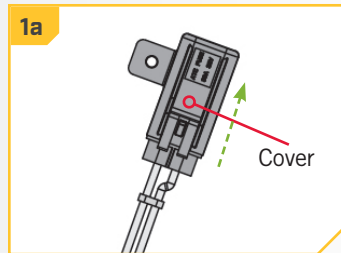

REPLACING THE SPIKE

The Spike for your Talon comes with a lifetime guarantee. See the Warranty section of the manual for further details. In order to replace the Spike, you must have enough room to extend the entire First Stage and the beginning of the Second Stage of the Talon. Determine if you have room to replace the Spike in the vertical position. If there is not enough space to replace the Spike in the vertical position, it may be required to remove the Talon from the Mounting Bracket. The Talon Tilt Bracket (1810222) is an accessory available to make this process easier. With this accessory, you don't have to remove the Talon from the mount to replace the Spike as it allows the Talon to be rotated into a horizontal position.

NOTICE: The Talon Tilt Bracket accessory (1810222) is available to make this process easier. With this accessory, you don't have to remove the Talon from the mount to replace the Spike.



TOOLS AND RESOURCES REQUIRED >

- Pin Punch 1/8"
- Hammer
- 3/32" Allen Wrench

REPLACE THE SPIKE

INSTALLATION

1

- a. Press the Down  button on the Indicator Panel or the Down  button on the Remote to extend the Spike out so that the Second Stage begins to exit the bottom of the Talon. This may require removing the Talon from the Mounting Bracket, and laying it horizontally on a flat surface.
- b. Once extended, remove the Talon from the Power Source.



CAUTION

Before beginning any maintenance work, disconnect the Talon from the battery or if connected to a battery selector switch or power disconnect switch, make sure that it is turned to the "off" position. Failure to disconnect power during maintenance work may result in shock, unexpected operation and/or injury.

2

- c. Locate the Spike Isolator Retainer Pin in the Second Stage of the Talon. Carefully remove the Retainer Pin using a Pin Punch and Hammer.
- d. Set the Spike Isolator Retainer Pin aside for later use, in reassembly. Slide the Spike Isolator along the Spike, away from the Second Stage.
- e. Gently pivot the Second Stage Debris Shield up out of the way to access the Spike Retainer Screw. The adjacent plastic Debris Channel Tab will bend slightly, but can be tapped back into place with a small hammer after the Spike is replaced.

NOTICE: It is normal to experience cosmetic changes in the appearance of the Debris Channel Tab during this procedure.

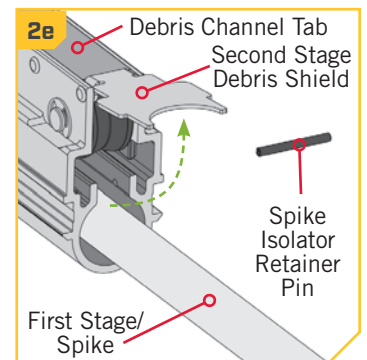
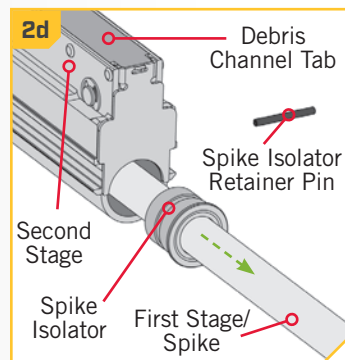
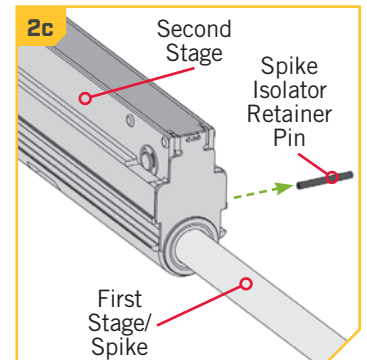
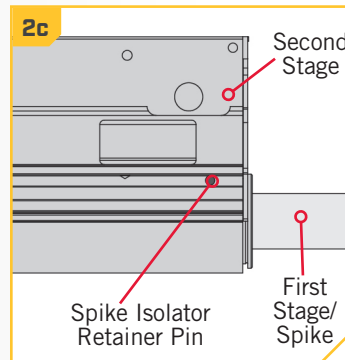

REPLACE THE SPIKE

3

- f. Locate the Spike Retainer Screw and remove it using a 3/32" Allen Wrench.
- g. Once removed, the Spike should pull free from the Second Stage along with the Spike Retainer and an O-ring that is in place around the Spike. The Spike Retainer is the piece that the Spike Retainer Screw was just removed from.
- h. Discard the Spike Retainer Screw, Spike, O-ring and Spike Isolator that were just removed. Keep the Spike Retainer for reassembly.

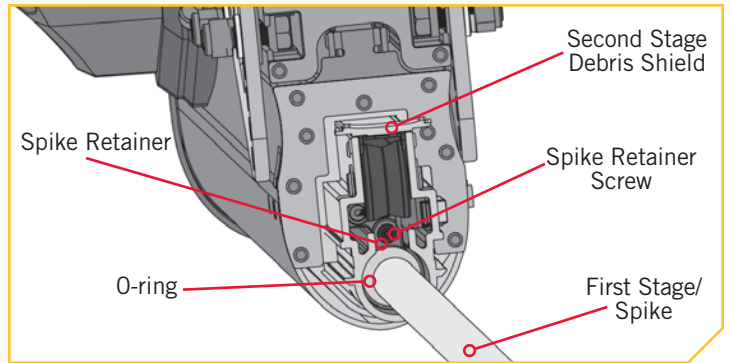

4

- i. Take the new Spike and locate the groove along one end. Slide the new Spike Isolator and then O-ring onto the Spike on the end where the groove is located. Slide them down so they are 5 to 6 inches past the end of the Spike.
- j. Locate the raised ring on the inside curve of the Spike Retainer and align it with the groove at the end of the Spike. Place the Spike Retainer on the Spike so that it is keyed in place by aligning the raised ring and groove.

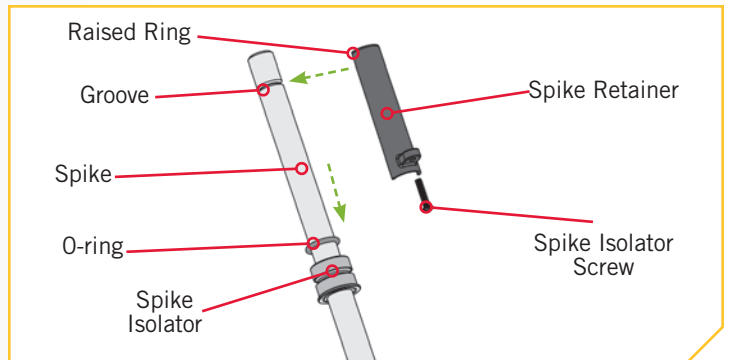

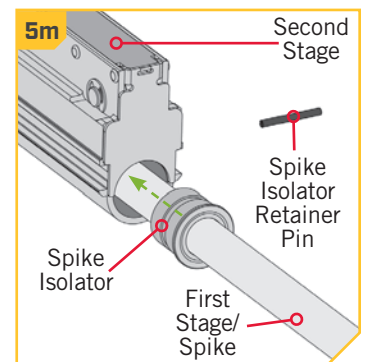
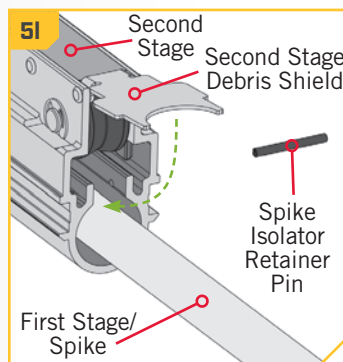
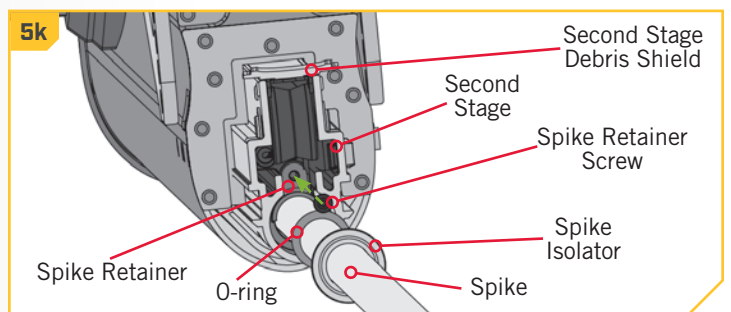

5

- k. Slide the assembly back into the Second Stage and replace the Spike Retainer Screw in the Spike Retainer using a 3/32" Allen Wrench.
- l. Once the Screw is secure, close the Second Stage Debris Shield.
- m. Push the O-ring and Spike Isolator towards the Second Stage and until they are in position against the Spike Retainer and Second Stage Debris Shield.



REPLACE THE SPIKE

6

- n. Carefully replace the Spike Isolator Retainer Pin, making sure the ends of the pin are recessed on both sides.
- o. If the Talon was removed to replace the Spike, reassemble the Talon into the Mounting Bracket. Reconnect power before using the Talon or retracting the Spike.
- p. Press the Up  button on the Indicator Panel or the Up  button on the Remote to retract the Talon.

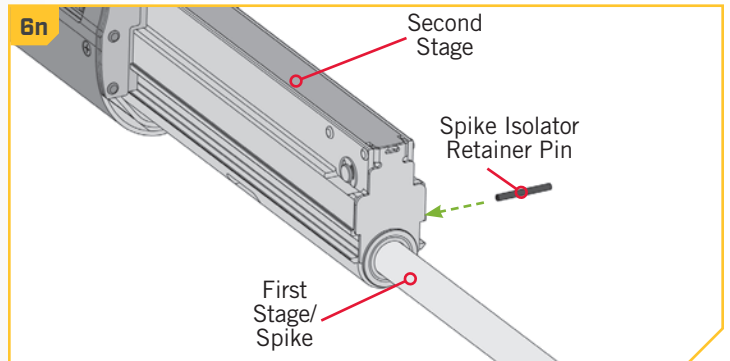

GENERAL MAINTENANCE



CAUTION

Before beginning any maintenance work, disconnect the Talon from the battery or if connected to a battery selector switch or power disconnect switch, make sure that it is turned to the "off" position. Failure to disconnect power during maintenance work may result in shock, unexpected operation and/or injury. The Talon may be imbalanced and fall during maintenance work. Support the full length of the Talon, including when the Spike is extended, to keep it properly secured and balanced during maintenance work.

Minn Kota recommends as part of your normal routine, to rinse the Talon to minimize any build up on the anchor. Following one of the rinse practices listed below is recommended after every use.

› 30 Second Deep Water Rinse

(Recommended)

1. Before docking / trailering your boat, enter into water depths that exceed the depth capacity of your Talon in an area free of obstructions.
2. Double click the Down Button  on the remote to auto deploy the Talon to full extension.
3. Place the main engine into gear AT IDLE ONLY.
4. Single click the Up Button  on the remote.

› Extended Hose Rinse

1. Lay the Talon down and extend fully.
2. For simplicity, we suggest using a Talon Tilt Bracket accessory (1810222). Otherwise, remove the Talon from the mounting bracket and lay down to extend for rinsing.
3. Rinse the sections of the Talon thoroughly while extended.
4. Retract the Talon, and return it to its upright installed position.

› Additional Maintenance

- After the Talon is in use, periodically check the Hex Head Cap Screws and Nylock Nuts on the Mounting Bracket and tighten them to 30 in-lbs.
- Inspect the Talon Power Cable and wires for signs of wear and keep them free and clear from high traffic areas to avoid damage.
- Inspect the Spike after each use to check for wear, damage or fractures. Replace the Spike if damage is present.

TROUBLESHOOTING



TROUBLESHOOTING

1. Why do I want to be able to adjust the Talon up or down when mounting on my boat?
 - Each boat sits differently in the water, and has varying amounts of draft (hull under the waterline). While Minn Kota recommends that the Talon mounting bracket be mounted as high up on the transom as possible, Minn Kota also recommends that the bottom of the Talon be a minimum of 4" up from the bottom line of the hull of your boat. Having this adjustability will minimize any spray that may occur while under way, and offer the greatest amount of stability to the Talon.
2. When do I want to use the reverse angle on the bracket when mounting the Talon?
 - Some boat models have transoms that angle towards the inside of the boat. In these cases, the Talon quick release bracket can be inverted to account for this reversed angle without the hassle of shims.
3. Do I need a separate battery to operate the Talon?
 - No. Minn Kota recommends connecting your Talon to the starting/cranking battery of your boat.
4. Can I install an electrical plug on the Talon lead wires?
 - Yes. Minn Kota offers a quick disconnect plug accessory (1810244) specifically designed for the Talon.
5. How do I determine where and how to mount the Talon?
 - This will vary from one boat to the next. It is important to check for proper steering and trimming clearances when laying out your installation. See the Installation section of this Manual for detailed instructions.
6. Which side of the boat do I want to install the Talon?
 - Minn Kota recommends installing your Talon on the port (left) side of your boat in order to give you the maximum amount of clearance between the boat engine and the control panel of the Talon. However, the Talon can be installed on either side or both sides of the boat.
7. How do I mount the Talon when I have trim tabs?
 - Talon requires a minimum of 6" of clearance from the mounting surface. If further clearance is required, or it is necessary to mount over top of trim tabs, Minn Kota offers a 6" riser accessory and a variety of adapter plates that will give you the proper amount of setback (distance from the transom) to clear trim tabs and/or other accessories.
8. How do I know when I should use a mounting adapter bracket?
 - Some boats have irregular-shaped transoms and the standard Talon quick release mounting bracket cannot be mounted directly to the transom. In other cases there are other accessories such as trim tabs, transducers, poling platforms, etc., that may require additional clearance. Use the Talon Adapter Bracket Selection Guide to select the proper application for your boat.

NOTICE: For all other malfunctions, visit an Authorized Service Center. You can search for an Authorized Service Center in your area by visiting our Authorized Service page, found online at minnkotamotors.com, or by calling our customer service number at 800-227-6433.

FOR FURTHER TROUBLESHOOTING AND REPAIR

FOR FURTHER TROUBLESHOOTING AND REPAIR

We offer several options to help you troubleshoot and/or repair your product. Please read through the options listed below.



Buy Parts Online

You can buy parts on-line directly from our website at minnkotamotors.com. Orders confirmed by 12 Noon Central Time, with Overnight Shipping selected, should ship the same business day if the parts are in stock. All other orders should ship within the next 3 business days, depending on the shipment method chosen, and if the parts are in stock.



Frequently Asked Questions

We have FAQs available on our website to help answer all of your Minn Kota questions. Visit minnkotamotors.com and click on “Frequently Asked Questions” to find an answer to your question.



Call Us (for U.S. and Canada)

Our consumer service representatives are available Monday – Friday between 7:00 a.m. – 4:30 p.m. CST at 800-227-6433. If you are calling to order parts, please have the 11-character serial number from your product, specific part numbers, and credit card information available. This will help expedite your call and allow us to provide you with the best consumer service possible. You can reference the parts list located in your manual to identify the specific part numbers.



Email Us

You can email our consumer service department with questions regarding your Minn Kota products. To email your question, visit minnkotamotors.com and click on “Support”.



Authorized Service Centers

Minn Kota has over 800 authorized service providers in the United States and Canada where you can purchase parts or get your products repaired. Please visit our Authorized Service Center page on our website to locate a service provider in your area.



Scan to visit Minn Kota service online.

COMPLIANCE STATEMENTS

ENVIRONMENTAL COMPLIANCE STATEMENT

It is the intention of JOME to be a responsible corporate citizen, operating in compliance with known and applicable environmental regulations, and a good neighbor in the communities where we make or sell our products.

WEEE DIRECTIVE

EU Directive 2002/96/EC “Waste of Electrical and Electronic Equipment Directive (WEEE)” impacts most distributors, sellers, and manufacturers of consumer electronics in the European Union. The WEEE Directive requires the producer of consumer electronics to take responsibility for the management of waste from their products to achieve environmentally responsible disposal during the product life cycle.

WEEE compliance may not be required in your location for electrical & electronic equipment (EEE), nor may it be required for EEE designed and intended as fixed or temporary installation in transportation vehicles such as automobiles, aircraft, and boats. In some European Union member states, these vehicles are considered outside of the scope of the Directive, and EEE for those applications can be considered excluded from the WEEE Directive requirement.

This symbol (WEEE wheelie bin) on product indicates the product must not be disposed of with other household refuse. It must be disposed of and collected for recycling and recovery of waste EEE. Johnson Outdoors Inc. will mark all EEE products in accordance with the WEEE Directive. It is our goal to comply in the collection, treatment, recovery, and environmentally sound disposal of those products; however, these requirements do vary within European Union member states. For more information about where you should dispose of your waste equipment for recycling and recovery and/or your European Union member state requirements, please contact your dealer or distributor from which your product was purchased.

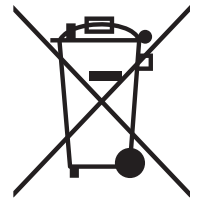

DISPOSAL

Minn Kota Talons are not subject to the disposal regulations EAG-VO (electric devices directive) that implements the WEEE directive. Nevertheless never dispose of your Minn Kota Talon in a garbage bin but at the proper place of collection of your local town council.

Never dispose of battery in a garbage bin. Comply with the disposal directions of the manufacturer or his representative and dispose of them at the proper place of collection of your local town council.

WARNING

This product contains chemicals known to the State of California to cause cancer and birth defects or other reproductive harm.

REGULATORY COMPLIANCE INFORMATION

› Talon

CONTROLLER : 2374151

- Contains IC: 216Q-1316
- Contains FCC ID: T7V1316



REMOTE : 2994150

- Contains IC: 5123A-BGTBLE121LR
- Contains FCC ID: QQQBLE121LR





FCC COMPLIANCE

This device complies with Part 15 of the FCC rules. Operation is subject to the following two conditions:

- 1. This device may not cause harmful interference.
2. This device must accept any interference that may be received, including interference that may cause undesired operation.

Changes or modifications not expressly approved by Johnson Outdoors Marine Electronics, Inc. could void the user's authority to operate this equipment.

NOTICE: This equipment has been tested and found to comply with the limits for a Class B digital device, pursuant to part 15 of the FCC Rules. These limits are designed to provide reasonable protection against harmful interference in a residential installation. This equipment generates, uses and can radiate radio frequency energy and, if not installed and used in accordance with the instructions, may cause harmful interference to radio communications. However, there is no guarantee that interference will not occur in a particular installation. If this equipment does cause harmful interference to radio or television reception, which can be determined by turning the equipment off and on, the user is encouraged to try to correct the interference by one or more of the following measures:

- Reorient or relocate the receiving antenna.
• Increase the separation between the equipment and receiver.
• Connect the equipment into an outlet on a circuit different from that to which the receiver is connected.
• Consult the dealer or an experienced radio/TV technician for help.

INDUSTRY CANADA COMPLIANCE

This product meets the applicable Industry Canada technical specifications. Operation is subject to the following two conditions: (1) this device may not cause interference, and (2) this device must accept any interference, including interference that may cause undesired operation of the device.

Changes or modifications not expressly approved by Johnson Outdoors Marine Electronics, Inc. could void the user's authority to operate this equipment.

ENVIRONMENTAL RATINGS

Ambient operating temperature range: -10C to 50C
Ambient operating humidity range: 5% to 95%
Maximum operating altitude: 10,000 feet

RADIO OPERATION

CONTROLLER

- Frequency band: 2402 MHz to 2480 MHz
• Maximum RF power transmitted: +10 dBm

REMOTE

- Frequency band: 2402 MHz to 2480 MHz
• Maximum RF power transmitted: +10 dBm

TRADEMARKS

Minn Kota®, i-Pilot® and i-Pilot® Link™ are trademarked by or registered trademarks of Johnson Outdoors Marine Electronics, Inc.

The Bluetooth® word mark and logos are registered trademarks owned by Bluetooth SIG, Inc. and any use of such marks by Johnson Outdoors Inc is under license. Other trademarks and trade names are those of their respective owners.

CE MASTER USER MANUAL [FOR CE CERTIFIED MODELS]



PARTS DIAGRAM & PARTS LIST

TALON

12 VOLT - 8'/10'/12'/15' TALON

The parts diagram and parts list provides Minn Kota® WEEE compliance disassembly instructions. For more information about where you should dispose of your waste equipment for recycling and recovery and/or your European Union member state requirements, please contact your dealer or distributor from which your product was purchased. Tools required, but not limited to: flat head screwdriver, Phillips screwdriver, socket set, pliers, wire cutters.

TALON INSTALLATION HARDWARE AND REMOTE >

> Installation Hardware & Remote Parts Diagram

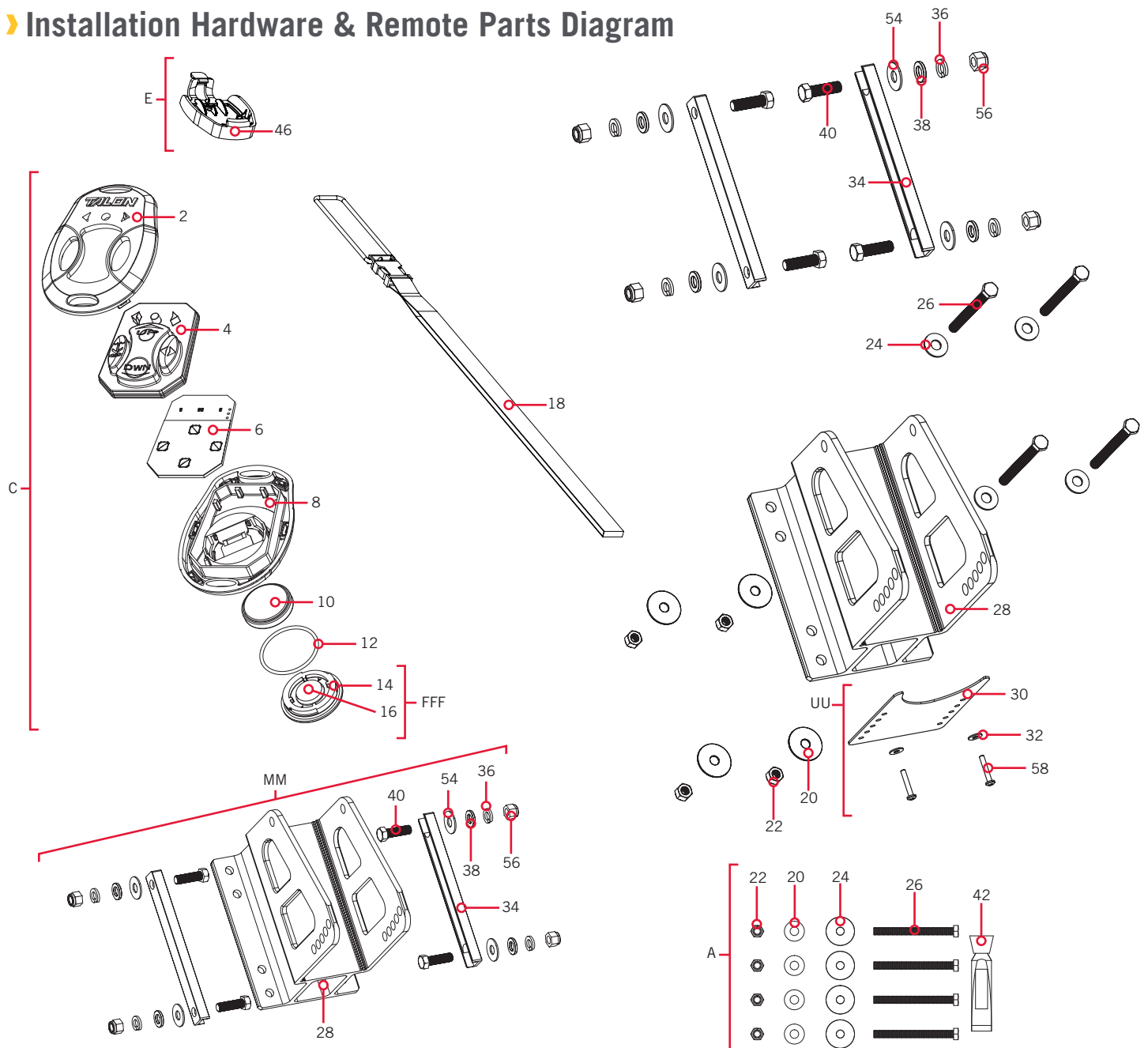

PARTS DIAGRAM & PARTS LIST

Installation Hardware & Remote Parts List

Assembly	Part #	Description	Quantity
A	2994903	TALON HARDWARE BAG ASSY	1
C	2994150	TRANSMITTER ASM, TALON 3	2
E	2771829	BRACKET,DASH MNT HLDR/TAPE KIT	1
MM	2778725	TILT BRACKET & HARDWARE KIT	1
UU	2886447	WATER SHIELD KIT, TALON BT	1
FFF	2886422	COVER, BATTERY COMPARTMENT ASY	1
Item	Part #	Description	Quantity
2	2372542	CASE-REMOTE, TOP, TALON 3	1
4	2375122	KEYPAD-REMOTE, TALON 3	1
6	✖	CTRL BOARD, TRNSMTR, TALON 3	1
8	2372545	CASE-REMOTE, BTM, TALON 3	1
10	✖	BATTERY CR2450	1
12	2376941	GASKET,BATTERY COMPARTMENT	1
14	✖	COVER, BATTERY COMPRT(SUB)	1
16	✖	PAD-FOAM, I-PILOT 1.5	1
18	2390801	LANYARD, REMOTE	1
20	2371752	WASHER-FENDER, 5/16, SS	4
22	2223100	NUT-5/16-18 NYLOCK S/S	4
24	2371749	WASHER-FLAT 5/16 SS	4
26	2373525	BOLT-5/16-18 X 3 1/2" HHCS SS	4
28	2378725	BRACKET-TILT-MACH	1
30	2376447	WATER SHIELD, DEFLECTOR - TALON 2	1
32	2371754	#8 WASHER, 1/2" OD, SS	2
34	2373815	TALON MOUNTING STRAP, T2	2
36	3391706	WASHER, LOCK - 3/8"	4
38	2371758	3/8 HD FLAT WASHER, SS	4
40	2383459	3/8-24 X 1.25 HHCS, SS	4
42	2378608	ANTI SEIZE TUBE, 4CC, TALON	1
44	2014802 ▲	BAG-ZPLCK(4X6)4ML ANTISTATIC	1
46	2371829	BRACKET, RMT DASH MNT HLDR	1
48	2375104 ▲	TAPE, MNTG FOAM ULINE #S-10131	1
50	2377170 ▲	MANUAL, TALON BT	1
52	2377171 ▲	MANUAL, INSTALL GUIDE T3	1
54	2378716	GUARD, EXTRUSION BRACKET	4
56	2373138	3/8-24 NYLOK NUT, SS	4
58	2263434	#8-18 X 1 SS PPH	2
60	2297165 ▲	MANUAL-DISCLAIMER, DWNLOAD INFO	1

✖ This part is included in an assembly and cannot be ordered individually.

▲ Not shown on Parts Diagram.

PARTS DIAGRAM & PARTS LIST

TALON MOTOR

Motor Parts Diagram

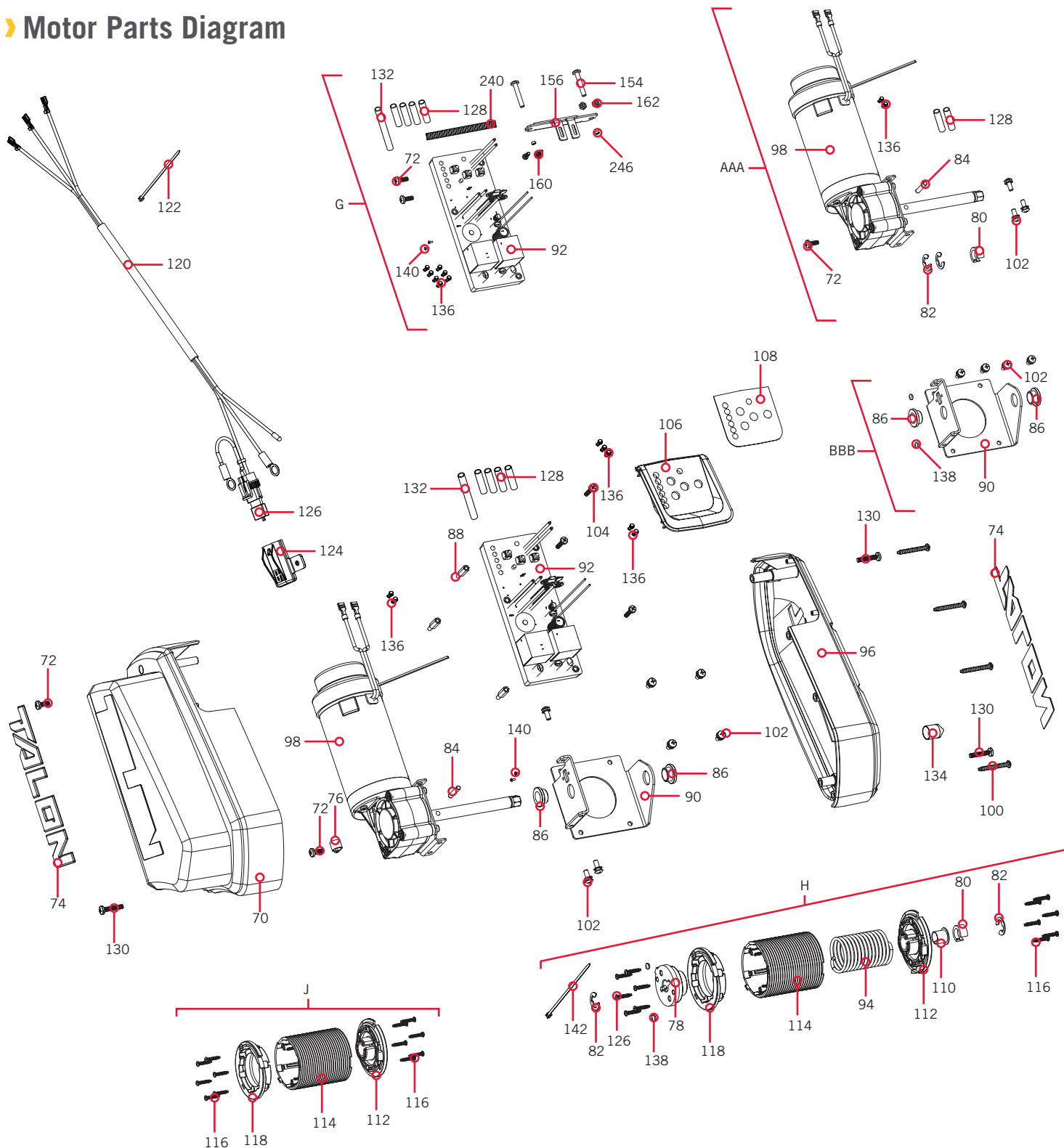

PARTS DIAGRAM & PARTS LIST

Motor Parts List

Assembly	Part #	Description	Quantity
G	2774151	CONTROL BOARD KIT, TALON BT	1
H	2777921	WRAP DRUM REPLACEMENT KIT BT	1
J	2997921	MODULAR WRAP DRUM ASM - TALON 3 - 15FT	1
AAA	2887822	MOTOR ASM KIT, TALON BT	1
BBB	2888745	MOTOR MOUNT WRAP DRUM KIT	1
Item	Part #	Description	Quantity
70	2376581	HOUSING,LEFT,BLACK,TALON 3 *8FT RED* *8FT BLUE* *8FT BLACK* *8FT SILVER/BLACK* *10FT RED* *10FT BLUE* *10FT BLACK* *10FT SILVER/BLACK* *10FT SILVER/WHITE* *10FT WHITE* *15FT*	1
	2376582	HOUSING,LEFT,WHITE,TALON 3 *8FT SILVER/WHITE* *8FT WHITE* *10FT SILVER/WHITE* *10FT WHITE* *12FT SILVER/WHITE* *12FT WHITE*	1
72	2303434	SCREW-8-32 X 5/8 PPMS SS	2
74	2378871	DECAL, SIDE TALON 3	2
76	2040721	CLAMP CABLE, 3/16"	1
78	2377906	HUB, WRAP DRUM, ALUMINUM	1
80	2371537	WRAP DRUM SPACER	1
82	2373005	E-RING EXTERNAL SS .500	2
84	3392640	PIN, DRIVESHAFT	1
86	2227304	BUSHING-HAT 1/2" SHAFT BRONZE	2
88	2371538	CONTROL BOARD SPACER, T2	3
90	2378745	WRAP DRUM MOUNT, TALON 2	1
92	*	PCB-ASM, TALON 3	1
94	2372749	SPRING TORSION, WRAP DRUM - TALON 3	1
96	2376583	HOUSING,RIGHT,BLACK,TALON 3 *8FT RED* *8FT BLUE* *8FT BLACK* *8FT SILVER/BLACK* *10FT RED* *10FT BLUE* *10FT BLACK* *10FT SILVER/BLACK* *10FT SILVER/WHITE* *10FT WHITE* *15FT*	1
	2376584	HOUSING,RIGHT,WHITE,TALON 3 *8FT SILVER/WHITE* *8FT WHITE* *10FT SILVER/WHITE* *10FT WHITE* *12FT SILVER/WHITE* *12FT WHITE*	1
98	2377824	MOTOR ASM SEALED	1
100	2383457	8-16X1.5 PLASTITE, SS	4
102	2373481	SCREW-#10-32 X 1/2"SEMS PPH SS	7
104	2373487	#8-32 X 3/4", PPH, MACHINE, SS	3
106	2370257	COVER,BEZEL,BLACK,TALON 3 *8FT RED* *8FT BLUE* *8FT BLACK* *8FT SILVER/BLACK* *10FT RED* *10FT BLUE* *10FT BLACK* *10FT SILVER/BLACK* *10FT SILVER/WHITE* *10FT WHITE* *15FT*	1
	2370258	COVER,BEZEL,WHITE,TALON 3 *8FT SILVER/WHITE* *8FT WHITE* *10FT SILVER/WHITE* *10FT WHITE* *12FT SILVER/WHITE* *12FT WHITE*	1
108	2375878	DECAL- BT TALON BEZEL – BLACK *8FT RED* *8FT BLUE* *8FT BLACK* *8FT SILVER/BLACK* *8FT SILVER/WHITE* *10FT RED* *10FT BLUE* *10FT BLACK* *10FT SILVER/BLACK* *10FT SILVER/WHITE* *12FT RED* *12FT BLUE* *12FT BLACK* *12FT SILVER/BLACK* *12FT SILVER/WHITE* *15FT BLACK* *15FT SILVER/BLACK*	1
	2375879	DECAL- BT TALON BEZEL – WHITE *8FT WHITE* *10FT WHITE* *12FT WHITE*	1

* This part is included in an assembly and cannot be ordered individually.

▲ Not shown on Parts Diagram.

PARTS DIAGRAM & PARTS LIST



Item	Part #	Description	Quantity
110	2376012	BEARING, WRAP DRUM	1
112	✖	FLANGE CLOSED END	1
114	✖	WRAP DRUM MODULAR, TALON 3	1
116	✖	SCREW, #6 X 0.50 SS HI-LOW	12
118	✖	FLANGE, OPEN END	1
120	2778514	POWER CORD	1
122	9950433	TIE WRAP, 4"	1
124	2990279	RESETTABLE FUSE, CAP W LABEL	1
126	2378231	RESETTABLE FUSE	1
128	2305404	SHRINK TUBE-.374 ID X 1.0"	4
130	2383458	8-32X1 PPH, SS	3
132	2305402	SHRINK TUBE-.374 ID X 2.25"	1
134	2376727	CAP PLUG VINYL 1/2"	1
136	2040340	CONNECTOR, SCOTCHLOK, UY2	7
138	✖	MAGNET-.187X.125NCKL PLT	2
140	2373485	SCREW-#6-32X1/4"PPH SS	2
142	✖	TIE WRAP-DH35 11.5"	1

✖ This part is included in an assembly and cannot be ordered individually.

▲ Not shown on Parts Diagram.



TALON OUTER EXTRUSION

Outer Extrusion Parts Diagram

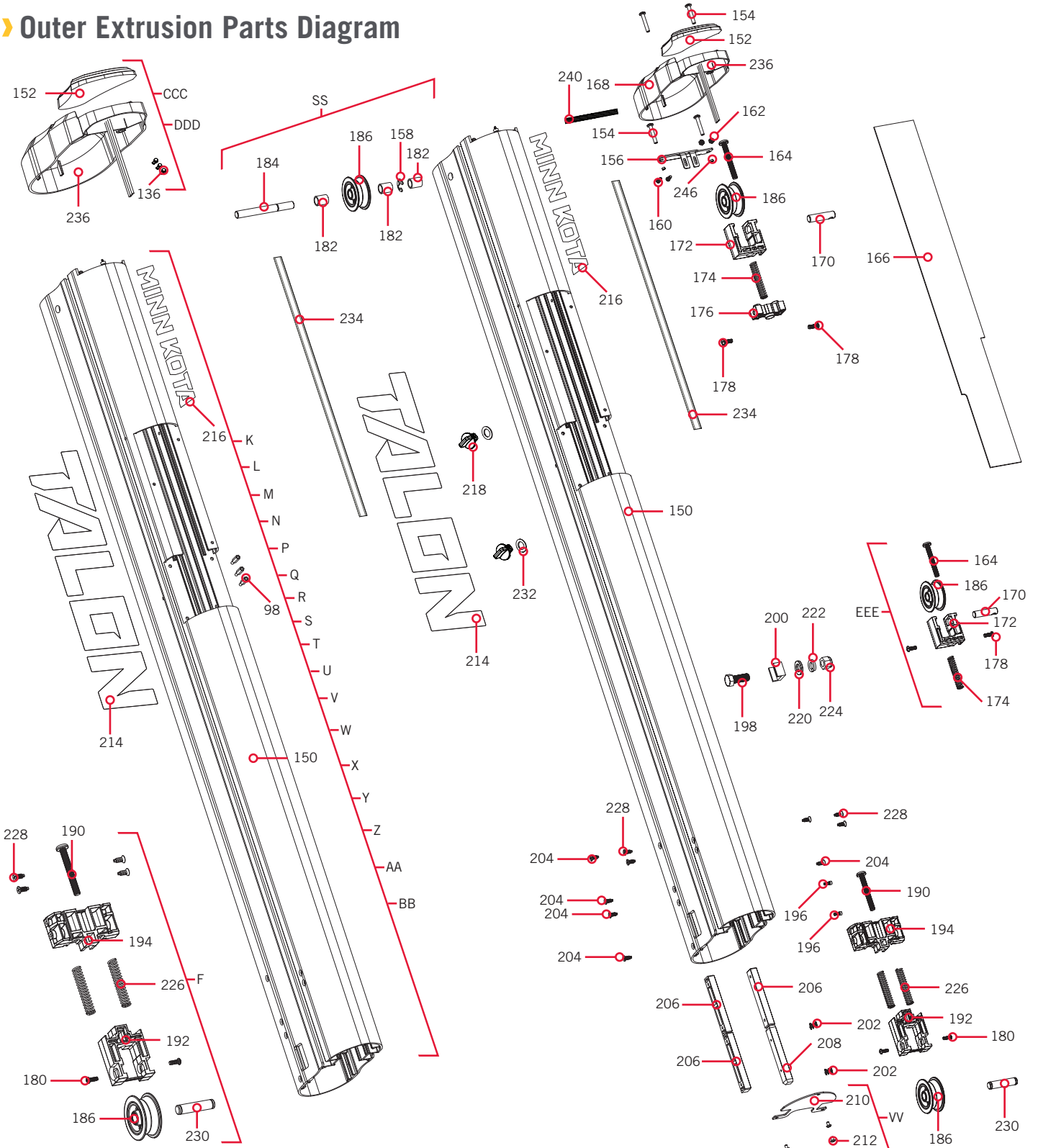

PARTS DIAGRAM & PARTS LIST

Outer Extrusion Parts List

Assembly	Part #	Description	Quantity
F	2273631	EXTENSIONER CABLE TENSIONER KIT	1
K	2777940	EXTRUSION 8' SLVR BT RPLC KIT	1
L	2777941	EXTRUSION 8' BLACK BT RPLC KIT	1
M	2777942	EXTRUSION 8' BLUE BT RPLC KIT	1
N	2777943	EXTRUSION 8' RED BT RPLC KIT	1
P	2777944	EXTRUSION 8' WHITE BT RPLC KIT	1
Q	2777945	EXTRUSION 10' SLVR BT RPLC KIT	1
R	2777946	EXTRUSION 10' BLK BT RPLC KIT	1
S	2777947	EXTRUSION 10' BLUE BT RPLC KIT	1
T	2777948	EXTRUSION 10' RED BT RPLC KIT	1
U	2777949	EXTRUSION 10' WHT BT RPLC KIT	1
V	2777950	EXTRUSION 12' SLVR BT RPLC KIT	1
W	2777951	EXTRUSION 12' SLVR BT RPLC KIT	1
X	2777952	EXTRUSION 12' BLUE BT RPLC KIT	1
Y	2777953	EXTRUSION 12' RED BT RPLC KIT	1
Z	2777954	EXTRUSION 12' WHT BT RPLC KIT	1
AA	2777955	EXTRUSION 15' SLVR BT RPLC KIT	1
BB	2777956	EXTRUSION 15' BLK BT RPLC KIT	1
SS	2882660	UPPER PULLEY KIT, LARGE	1
VV	2886470	WATER GUARD KIT, TALON BT	1
CCC	2994151	TALON BT TOP CAP ASM, WHT	1
DDD	2994152	TALON BT TOP CAP ASM, BLK	1
EEE	2772350	TENSIONER ASSEMBLY KIT	1
Item	Part #	Description	Quantity
150	*	OUTER EXTRUSION 8' BRIGHT CLEAR *8FT SILVER/BLACK* *8FT SILVER/WHITE*	1
	*	OUTER EXTRUSION 8' BLACK *8FT BLACK*	1
	*	OUTER EXTRUSION 8' BLUE *8FT BLUE*	1
	*	OUTER EXTRUSION 8' RED *8FT RED*	1
	*	OUTER EXTRUSION 8' WHITE *8FT WHITE*	1
	*	OUTER EXTRUSION 10' BRIGHT CLEAR *10FT SILVER/BLACK* *10FT SILVER/WHITE*	1
	*	OUTER EXTRUSION 10' BLACK *10FT BLACK*	1
	*	OUTER EXTRUSION 10' BLUE *10FT BLUE*	1
	*	OUTER EXTRUSION 10' RED *10FT RED*	1
	*	OUTER EXTRUSION 10' WHITE *10FT WHITE*	1
	*	OUTER EXTRUSION 12' BRIGHT CLEAR *12FT SILVER/BLACK* *12FT SILVER/WHITE*	1
	*	OUTER EXTRUSION 12' BLACK *12FT BLACK*	1

* This part is included in an assembly and cannot be ordered individually.

▲ Not shown on Parts Diagram.

PARTS DIAGRAM & PARTS LIST



Item	Part #	Description	Quantity
150	*	OUTER EXTRUSION 12' BLUE *12FT BLUE*	1
	2377953	OUTER EXTRUSION 12' RED *12FT RED*	1
	2377954	OUTER EXTRUSION 12' WHITE *12FT WHITE*	1
	2377955	OUTER EXTRUSION 15' BRIGHT CLEAR *15FT SILVER/BLACK*	1
	2377956	OUTER EXTRUSION 15' BLACK *15FT BLACK*	1
152	2378870	DECAL, COVER, TALON 3	1
154	2263434	#8-18 X 1 SS PPH	4
156	2378705	SENSOR BRACKET, TALON2	1
158	2370832	C-CLIP, 3/8 LOW CLEARANCE - SS	1
160	2373439	SCREW-#4-40 X 5/16" PPH SS	2
162	2373106	NUT-#4-40, NYLOK, SS	2
164	*	SCREW, 1/4 -20 X 2.75" PPH, SS	1
166	2378865	CHANNEL DIVIDER, 8' *8 FT*	1
	2378866	CHANNEL DIVIDER, 10'/12' *10FT* *12FT*	1
	2378867	CHANNEL DIVIDER, 15' *15FT*	1
168	2370252	COVER, BLACK, TALON 3 *8FT RED* *8FT BLUE* *8FT BLACK* *8FT SILVER/BLACK* *10FT RED* *10FT BLUE* *10FT BLACK* *10FT SILVER/BLACK* *10FT SILVER/WHITE* *10FT WHITE* *15FT*	1
	2370253	COVER, WHITE, TALON 3 *8FT SILVER/WHITE* *8FT WHITE* *10FT SILVER/WHITE* *10FT WHITE* *12FT SILVER/WHITE* *12FT WHITE*	1
170	*	TENSIONER-PULLEY-PIN	1
172	*	TENSIONER BLOCK	1
174	2372742	SPRING, PISTON	1
176	2373201	TENSIONER STOP	1
178	*	#8-16 X 3/4 PLASTITE SCREW, SS	2
180	*	SCREW-1/4-20 X 1/2" MCH SS	2
182	2371765	PULLEY SPACER, SHORT	3
184	2372660	PIN, PULLEY-LONG, TALON2	1
186	*	LG IDLER PULLEY W BUSHING	3
190	*	SCREW-1/4-20 X 2" PPH SS/REI	1
192	*	SLIDE-EXTENSION TENSIONER	1
194	*	STOP-EXTENSION TENSIONER	1
196	2383468	SCREW, #4-40 X 5-16" SHCS SS	2
198	2373529	3/8-24 X 1" HHCS, SS	1
200	2372850	TALON STOP BOLT EXTRUSION MACHINED	1
202	2372740	SPRING, GIB TENSION	2
204	2383461	SCREW 8-18 X .437 HI-LO PFH	6
206	2372820	SLIDE GIB-LOWER	3
208	2372827	SLIDE GIB-UPPER FLOATING	1

* This part is included in an assembly and cannot be ordered individually.

▲ Not shown on Parts Diagram.



PARTS DIAGRAM & PARTS LIST



Item	Part #	Description	Quantity
210	2376470	DEBRIS SHIELD, BASE	1
212	2378601	STAINLESS POP RIVET, 1/8"	3
214	2376833	DECAL, BT TALON LOGO *8FT RED* *8FT BLUE* *8FT BLACK* *8FT SILVER/BLACK* *8FT SILVER/WHITE* *10FT RED* *10FT BLUE* *10FT BLACK* *10FT SILVER/BLACK* *10FT SILVER/WHITE* *12FT RED* *12FT BLUE* *12FT BLACK* *12FT SILVER/BLACK* *12FT SILVER/WHITE* *15FT BLACK* *15FT SILVER/BLACK*	1
	2376834	DECAL, BT TALON LOGO-WHITE *8FT WHITE* *10FT WHITE* *12FT WHITE*	1
216	2376835	DECAL, BT TALON 8 MK *8FT RED* *8FT BLUE* *8FT BLACK* *8FT SILVER/BLACK* *8FT SILVER/WHITE*	1
	2376836	DECAL, BT TALON 8 MK-WHITE *8FT WHITE*	1
	2376837	DECAL, BT TALON 10/12 MK *10FT RED* *10FT BLUE* *10FT BLACK* *10FT SILVER/BLACK* *10FT SILVER/WHITE* *12FT RED* *12FT BLUE* *12FT BLACK* *12FT SILVER/BLACK* *12FT SILVER/WHITE*	1
	2376838	DECAL, BT TALON 10/12 MK-WH *10FT WHITE* *12FT WHITE*	1
	2376839	DECAL, BT TALON 15 MK *15FT BLACK* *15FT SILVER/BLACK*	1
218	2372930	CORD RETAINER	2
220	2371758	3/8 HD FLAT WASHER, SS	1
222	3391706	WASHER LOCK - 3/8"	1
224	2373138	3/8-24 NYLOK NUT, SS	1
226	✖	SPRING, PISTON	2
228	2383474	SCREW-#8-16 X 1/2",PFH,SS,PLST	4
230	✖	PIN-EXTENSION TENSIONER	1
232	2371723	WASHER, POLYURETHANE 3/8"	2
234	2378758	CHANNEL COVER, 15'	2
	2378757	CHANNEL COVER, 11/12'	2
	2378756	CHANNEL COVER, 8'	2
236	✖	CTRL BOARD ASM, LED, TALON 3	1
238	2375559 ▲	LABEL, TALON BRKT TORQUE WARN.	1
240	2298800	LOOM-WIRE, 1/4 X 4"	1
246	2371780	SPACER #8 X .188	2

✖ This part is included in an assembly and cannot be ordered individually.

▲ Not shown on Parts Diagram.



TALON STAGE THREE

Stage Three Parts Diagram

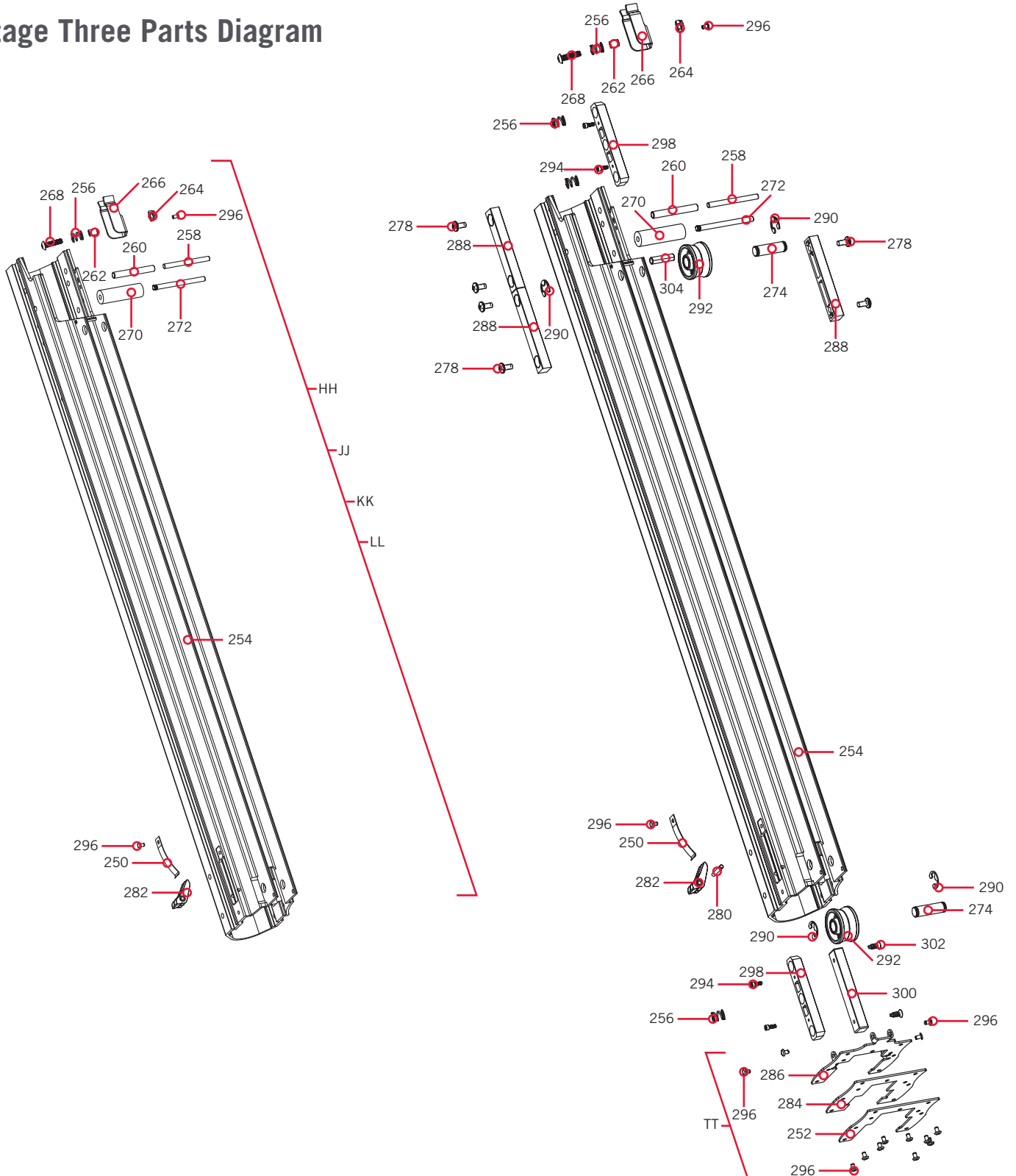

PARTS DIAGRAM & PARTS LIST

› Stage Three Parts List

Assembly	Part #	Description	Quantity
HH	2778091	THIRD STAGE EXTRS. 8' RPLC KIT	1
JJ	2778092	THIRD STAGE EXTRS.10' RPLC KIT	1
KK	2778093	THIRD STAGE EXTRS.12' RPLC KIT	1
LL	2778094	THIRD STAGE EXTRS.15' RPLC KIT	1
TT	2884665	WIPER, RIVET KIT, 2ND STAGE BT	1
Item	Part #	Description	Quantity
250	2372748	SPRING, LATCH STAGE 3 TALON	1
252	✱	WIPER RETAINER	1
254	2378091	THIRD STAGE MACHINED 8', TALON 3 *8FT*	1
	2378092	THIRD STAGE MACHINED 10', TALON 3 *10FT*	1
	2378093	THIRD STAGE MACHINED 12', TALON 3 *12FT*	1
	2378094	THIRD STAGE MACHINED 15', TALON 3 *15FT*	1
256	2372740	SPRING, GIB TENSION	2
258	2372669	PIN-DOWEL, 3RD STAGE SUPPORT	1
260	2372668	3RD STAGE SUPPORT PIN	1
262	2371781	SPACER, LATCH SS	1
264	2333101	#10-24 NYLOCK NUT, SS	1
266	2377220	CLIP, 3RD STAGE	1
268	2383469	SCREW-#10-24 X 3/4 SS, BHCS	1
270	2375418	2ND STAGE INSULATOR, 1/4" STOP PIN, TALON2	1
272	2372659	PIN-DOWEL 3/16" X 2.5" SS, TALON2	1
274	2372316	SHAFT, IDLER	2
278	2323409	SCREW-#10-24 X 3/8 PPH MACH SS	6
280	2372653	PIN, KNURLED - 1/8"	1
282	2377201	LATCH, THIRD STAGE MOLDED	1
284	✱	WIPER 2ND STAGE	1
286	✱	DEBRIS SHIELD, 2ND STAGE WIPER	1
288	2372828	SLIDE GIB-UPPER	3
290	2370832	C-CLIP, 3/8 LOW CLEARANCE - SS	4
292	2992365	SM IDLER PULLEY W BUSHING	2
294	2383468	SCREW, #4-40 X 5-16" SHCS SS	4
296	2378601	STAINLESS POP RIVET, 1/8"	15
298	2372827	SLIDE GIB-UPPER FLOATING	2
300	2372820	SLIDE GIB-LOWER	1
302	2383461	SCREW 8-18 X .437 HI-LO PFH	2
304	2372643	PIN-SPRING, 1/8 X 1, SS	1

✱ This part is included in an assembly and cannot be ordered individually.

▲ Not shown on Parts Diagram.

TALON STAGE TWO AND ONE

Stage Two & One Parts Diagram

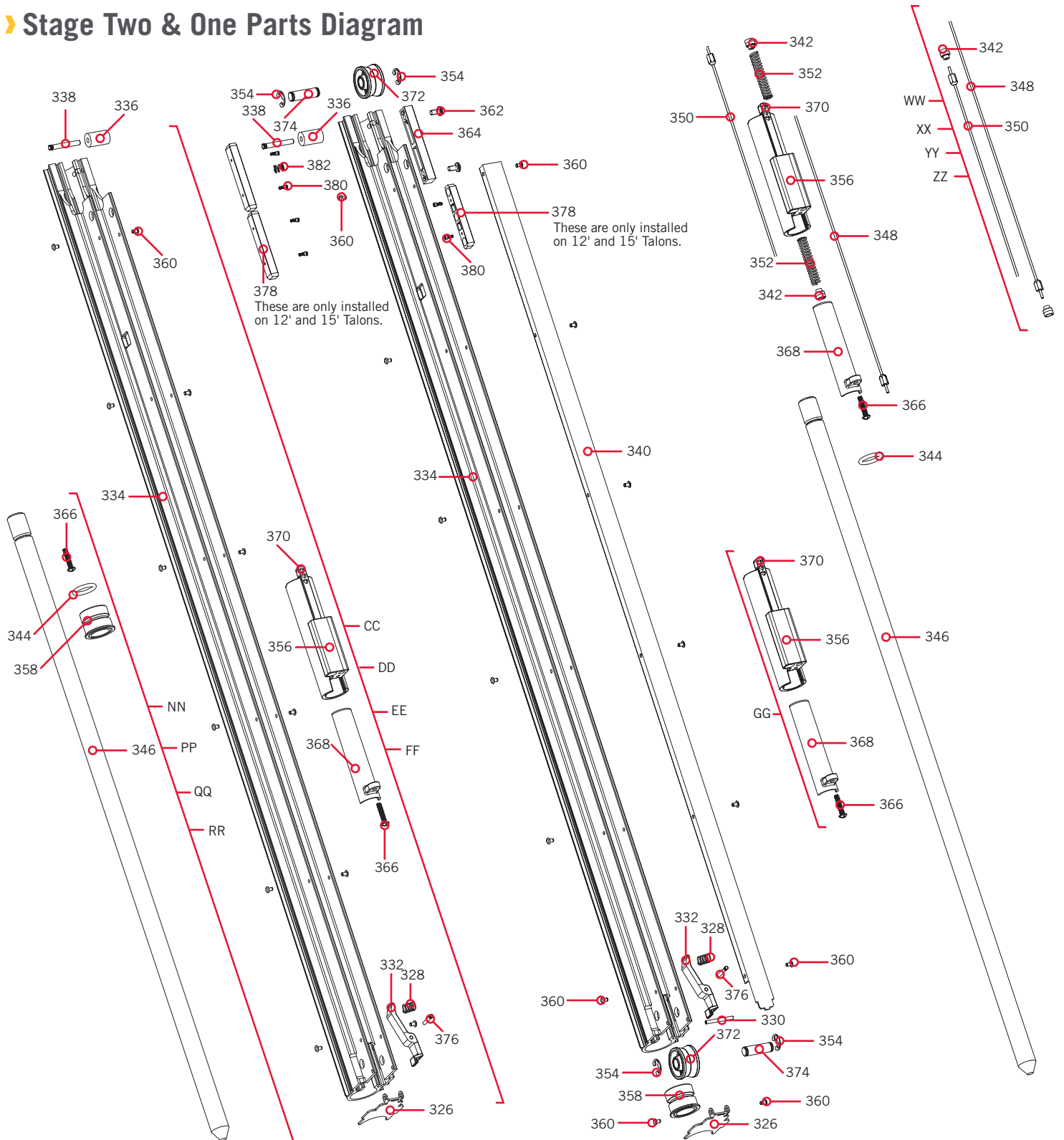

PARTS DIAGRAM & PARTS LIST

› Stage Two and One Parts List

Assembly	Part #	Description	Quantity
CC	2778056	SECOND STAGE EXTRS. 15' RPLC KIT	1
DD	2778057	SECOND STAGE EXTRS. 8' RPLC KIT	1
EE	2778058	SECOND STAGE EXTRS. 10' RPLC KIT	1
FF	2778059	SECOND STAGE EXTRS. 12' RPLC KIT	1
GG	2991545	TALON 3 PISTON ASSEMBLY	1
NN	2882028	SPIKE REPLACEMENT KIT, 15'	1
PP	2882007	SPIKE REPLACEMENT KIT, 10'	1
QQ	2882008	SPIKE RPLC KIT 12' / 2-STG 8'	1
RR	2882027	SPIKE REPLACEMENT KIT 8'	1
WW	2887520	CABLE RPLCMNT KIT 8' TALON BT	1
XX	2887522	CABLE RPLCMNT KIT 10' TALON BT	1
YY	2887524	CABLE RPLCMNT KIT 12' TALON BT	1
ZZ	2887526	CABLE RPLCMNT KIT 15' TALON BT	1
Item	Part #	Description	Quantity
326	2376440	2ND STAGE DEBRIS SHIELD	1
328	2372743	SPRING, .36 X .5	1
330	2372654	PIN, SPRING 1/8 X 1-1/4, SS	1
332	2377205	LATCH SECOND STAGE	1
334	2378057	SECOND STAGE, MACHINED 8', TALON 3	1
	2378058	SECOND STAGE, MACHINED 10', TALON 3	1
	2378059	SECOND STAGE, MACHINED 12', TALON 3	1
	2378056	SECOND STAGE, MACHINED 15', TALON 3	1
336	2375416	INSULATOR, 1/4" STOP PIN	1
338	2372645	3/16" X 1.5" KNURLED PIN, SS	1
340	2378826	DEBRIS CHANNEL, 8' *8FT*	1
	2378823	DEBRIS CHANNEL, 10' *10FT*	1
	2378824	DEBRIS CHANNEL, 12' *12FT*	1
	2378827	DEBRIS CHANNEL, 15' *15FT*	1
342	2370850	CABLE KEEPER	2
344	2374632	O-RING, 3/4" ID X .125 *8FT* *10FT* *12FT*	1
346	✘	SPIKE, .75" X 56.4" (15') *15FT*	1
	✘	SPIKE, .75" X 56.4" (12') *12FT*	1
	✘	SPIKE, .75" X 48.4" (10') *10FT*	1
	✘	SPIKE, .75" X 40.4", (8') *8FT*	1

✘ This part is included in an assembly and cannot be ordered individually.

▲ Not shown on Parts Diagram.

PARTS DIAGRAM & PARTS LIST



Item	Part #	Description	Quantity
348	✖	CABLE ASM TLN3, EXT 15' *15FT*	1
	✖	CABLE ASM TLN3, EXT 12' *12FT*	1
	✖	CABLE ASM TLN3, EXT 10' *10FT*	1
	✖	CABLE ASM TLN3, EXT 8' *8FT*	1
350	✖	CABLE ASM TLN3, RET 15' *15FT*	1
	✖	CABLE ASY, 2MM, RETRACT 10/12 *10FT* *12FT*	1
	✖	CABLE ASY, 2MM, RETRACT 8' (SUB) *8FT*	1
352	2372742	SPRING, PISTON	2
354	2370832	C-CLIP, 3/8 LOW CLEARANCE - SS	4
356	2371545	PISTON-TALON 3	1
358	2778825	SPIKE ISOLATOR	1
360	2378601	STAINLESS POP RIVET, 1/8"	12
362	2323409	SCREW-#10-24 X 3/8 PPH MACH SS	2
364	2372828	SLIDE GIB-UPPER	1
366	2383477	#8-16 X 7/8" PLASTITE SCREW, SS	1
368	2372932	RETAINER-STAKE, TALON 3	1
370	✖	.187 X .125 MAGNET	3
372	2992365	SM IDLER PULLEY W BUSHING	2
374	2372316	SHAFT, IDLER	2
376	2372653	PIN, KNURLED - 1/8"	1
378	2372827	SLIDE GIB-UPPER FLOATING	3
380	2383468	SCREW, #4-40 X 5-16" SHCS SS	6
382	2322740	SPRING, GIB TENSION	1

✖ This part is included in an assembly and cannot be ordered individually.

▲ Not shown on Parts Diagram.



RECOMMENDED ACCESSORIES

ON-BOARD & PORTABLE BATTERY CHARGERS

Stop buying new batteries and start taking care of the ones you've got. Many chargers can actually damage your battery over time – creating shorter run times and shorter overall life. Digitally controlled Minn Kota chargers are designed to provide the fastest charge that protect and extend battery life.



MK212PC



MK210D



MK110PD

TALON ACCESSORIES

UNIVERSAL MODULAR ADAPTER BRACKETS

It's easy to choose your bracket, easy to install it and pretty much impossible for anything to stop it. Talon's Universal Modular Adapter Brackets are built stronger than they have to be, and their innovative modular design lets you put Talon in just the right position on your boat.

Unparalleled Strength

We built Talon with uncompromising power. And we built the brackets the exact same way. Made with extruded aluminum and reinforced with rugged construction, our brackets hold Talon steady whether you're trailering or tearing through heavy chop.

Jack Plate Adapter Bracket

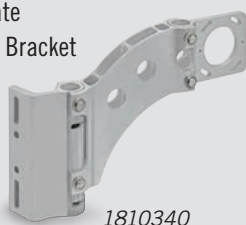

1810340

Sandwich-Style Adapter Bracket



1810244
1810303

Universal Modular Design

Two brackets. Any transom. The universal design fits any situation, and the brackets can be adjusted and tweaked to the perfect orientation. Two pivot points let you adjust Talon to the perfect orientation (based on your transom style, outboard location and other factors). Once it's in position, interlocking teeth clamp down to lock it into place.

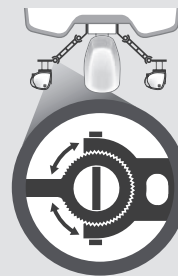

TALON TILT BRACKET

This marine-grade, anodized aluminum tilt bracket accommodates for low-clearance areas and boat storage. Features adjustable deck support for added stability while tilting.



1810222

