

Trolling Motor 360 Imaging™ Installation Guide

532178-1_A



 **HUMMINBIRD®**

Accessory Manual

Thank You!

Thank you for choosing Humminbird®, the #1 name in Fishfinders. Humminbird® has built its reputation by designing and manufacturing top-quality, thoroughly reliable marine equipment. Your Humminbird® accessory is designed for trouble-free use in even the harshest marine environment. In the unlikely event that your Humminbird® accessory does require repairs, we offer an exclusive Service Policy - free of charge during the first year after purchase, and available at a reasonable rate after the one-year period. For complete details, see the separate warranty card included with your accessory. We encourage you to read this manual carefully in order to get the full benefit from all the features and applications of your Humminbird® product.

Contact our Customer Resource Center at **1-800-633-1468** or visit our Web site at **humminbird.com**.

WARNING! *This device should not be used as a navigational aid to prevent collision, grounding, boat damage, or personal injury. When the boat is moving, water depth may change too quickly to allow time for you to react. Always operate the boat at very slow speeds if you suspect shallow water or submerged objects.*

WARNING! *The electronic chart in your Humminbird® unit is an aid to navigation designed to facilitate the use of authorized government charts, not to replace them. Only official government charts and notices to mariners contain all of the current information needed for the safety of navigation, and the captain is responsible for their prudent use.*

WARNING! *Humminbird® is not responsible for the loss of data files (waypoints, routes, tracks, groups, recordings, etc.) that may occur due to direct or indirect damage to the unit's hardware or software. It is important to back up your control head's data files periodically. Data files should also be saved to your PC before restoring the unit's defaults or updating the software. See your Humminbird® online account at **humminbird.com** and the Waypoint Management Guide on your Humminbird® Manual CD for details.*

WARNING! *Disassembly and repair of this electronic unit should only be performed by authorized service personnel. Any modification of the serial number or attempt to repair the original equipment or accessories by unauthorized individuals will void the warranty.*

WARNING! *This product contains chemicals known to the State of California to cause cancer and/or reproductive harm.*

WARNING! Do not travel at high speed with the unit cover installed. Remove the unit cover before traveling at speeds above 20 mph.

ATTENTION INTERNATIONAL CUSTOMERS: Products sold in the U.S. are not intended for use in the international market. Humminbird® international units provide international features and are designed to meet country and regional regulations. Languages, maps, time zones, units of measurement, and warranty are examples of features that are customized for Humminbird® international units purchased through our authorized international distributors.

To obtain a list of authorized international distributors, please visit our Web site at humminbird.com or contact our Customer Resource Center at (334) 687-6613.

ROHS STATEMENT: Product designed and intended as a fixed installation or part of a system in a vessel may be considered beyond the scope of Directive 2002/95/EC of the European Parliament and of the Council of 27 January 2003 on the restriction of the use of certain hazardous substances in electrical and electronic equipment.

NOTE: Some features discussed in this manual require a separate purchase, and some features are only available on international models. Every effort has been made to clearly identify those features. Please read the manual carefully in order to understand the full capabilities of your model.

NOTE: The illustrations in this manual may not look the same as your control head, but your product will function in the same way.

NOTE: To purchase accessories for your control head, visit our Web site at humminbird.com or contact our Customer Resource Center at 1-800-633-1468.

NOTE: The procedures and features described in this manual are subject to change without notice. This manual was written in English and may have been translated to another language. Humminbird® is not responsible for incorrect translations or discrepancies between documents.

360 Imaging™, 700 Series™, 800 Series™, 900 Series™, 1100 Series™, Fortrex™, Humminbird®, Maxxum®, Minn Kota®, WeatherSense®, and X-Press™ Menu are trademarked by or registered trademarks of Johnson Outdoors Marine Electronics, Inc.

© 2013 Johnson Outdoors Marine Electronics, Inc. All rights reserved.

Table of Contents

Introduction	1
Installation Preparation	2
Install the GPS Receiver/Heading Sensor	5
1. Choose the Mounting Location	5
2. Install the Sensor	6
A. Stem Mount with 1" - 14 Thread	7
B. Access Under the Mounting Location	9
C. No Access Under the Mounting Location	11
3. Connect to the Control Head	13
Install the Trolling Motor Bracket	15
1. Prepare for Installation	15
2. Install the Trolling Motor Bracket	16
3. Route the Cables and Connect Power	22
Set up the Control Head (700, 800, 900, and 1100 Series™)	25
1. Power on and Confirm Connections	25
2. Set up 360 Imaging on the Control Head	27
3. Test 360 Imaging on the Control Head	28
4. Confirm the Heading Sensor Operation	30
5. Add Offset Features to the 360 Imaging Display (optional)	32
6. Turn on NMEA Output and Confirm the Baud Rate <i>(for devices connected to the Sensor pigtail only)</i>	34
7. Set up the Network and Alarms	34
Power Off	35
Maintenance	36
Control Head Maintenance	36
Transducer Maintenance	37
Trolling Motor 360 Imaging Maintenance	37

Table of Contents

Troubleshooting	38
Fishing System Doesn't Power Up	38
Fishing System Defaults to Simulator with a Transducer Attached	39
Finding the Cause of Noise	40
Specifications	41
Contact Humminbird®	43

Introduction

This manual will guide you through the following installation requirements for the Trolling Motor 360 Imaging.

Installing the GPS Receiver/Heading Sensor

Installing the Trolling Motor Bracket

Connecting to the Control Head and Power

Testing the Installation

Powering Off

Before proceeding with this installation, the Humminbird control head and Minn Kota trolling motor should be installed. The 360 Imaging transducer can be connected directly to the control head or to a Humminbird Ethernet Switch (optional) for networking. See the Ethernet Switch accessory guide to install the Ethernet Switch.

NOTE: *The Trolling Motor 360 Imaging is compatible with the Minn Kota Fortrex and the Minn Kota Maxxum. See our Web site at humminbird.com for compatibility details.*

1 | Installation Preparation

Before you start the installation, please take a moment to familiarize yourself with the parts list and supplies list. We also encourage you to read the instructions beforehand so that you may understand the installation requirements.

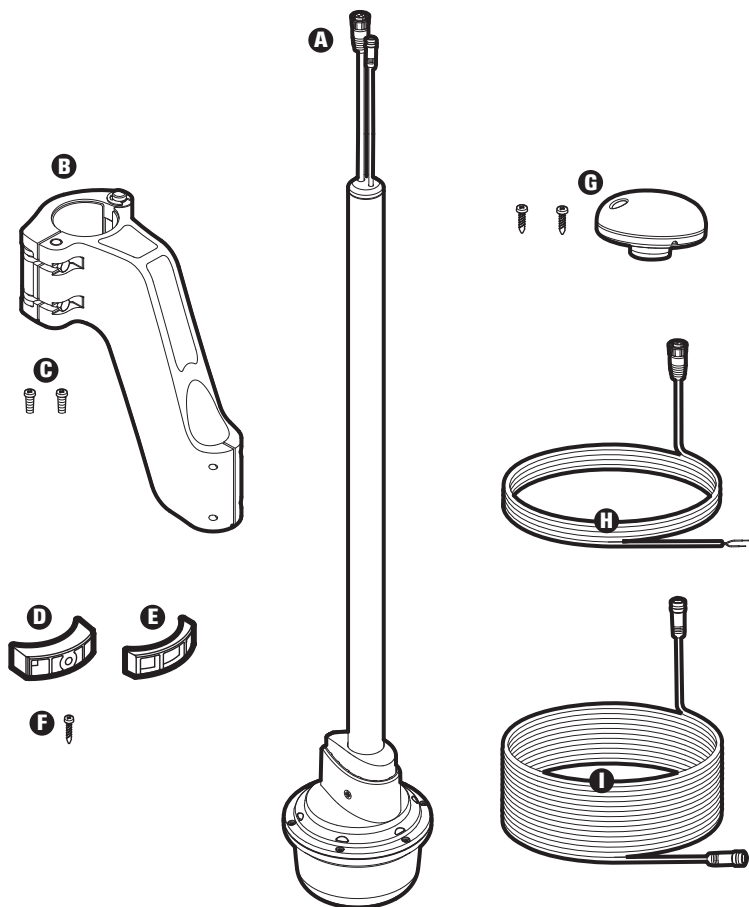

Parts

The Trolling Motor 360 Imaging includes the following items:

A 360 Imaging Transducer Pod

B Trolling Motor Bracket

C (2) 10-32 x 5/8" Hex Socket Bolts

D Large Insert (with screw hole)

E Small Insert

F #8 x 1/2" Screw

G GPS Receiver/Heading Sensor and Screws ([2] #8 – 1¼", ([2] #6 – 7/8")

H Power Cable (3', 1 m)

I Ethernet Cable (20', 6 m)

NOTE: Product supplies and features are subject to change without notice.

Supplies

In addition to the hardware included with your Trolling Motor 360 Imaging, you will need the following supplies:

Drill with various drill bits

Phillips Head Screw Driver

Allen wrench (5/32", 4 mm)

Hex socket wrench

Electrical Tape

Awl or Pencil

Marine-grade silicone caulk or sealant

Cable ties for cable routing

Tape measure

1 Amp fuse

Safety goggles

Dust mask

Cables: Depending on your Humminbird model and system configuration, you may need to purchase additional cables, as shown below. Visit our Web site at humminbird.com or call our Customer Resource Center at **1-800-633-1468**.

- **700 Series with Ethernet:** To connect the Ethernet to the control head, you will need to purchase the Ethernet Adapter Cable (AS EC QDE).
- **Extension Cables** are available for Ethernet and the GPS Receiver/Heading Sensor.
- **Y-Cable:** If the COM port on the control head is already used by another installed accessory, you will need to purchase a Humminbird Y-Cable to add the GPS Receiver/Heading Sensor to the installation.

Switch (optional): If you do not have a main switch or fuse panel available on your boat to connect power, you will need to purchase a battery switch. See *Install the Trolling Motor Bracket, Section 3: Route the Cables and Connect Power* for more information.

Install the GPS Receiver/Heading Sensor

Use the following instructions to install the GPS Receiver/Heading Sensor ("Sensor") on your boat.

1. Choose the Mounting Location

It is important to consider the following information when you choose a mounting location for the Sensor:

- **Interference:** Do NOT mount the Sensor close to a VHF antenna or within the active area of a radar. Do NOT install the Sensor near ferrous metals or near anything that can create a magnetic field. Hardware and cables that handle large currents, such as batteries and power cables, are also examples of equipment that may cause interference.
- **Reception:** Mount the Sensor in an area that has full exposure to the sky. The effective area of reception is 5° above the horizon.
- **Surface:** Whether the Sensor Cable will be routed down through the mounting surface or to the side, or if you're using a stem mount, the mounting surface will influence how you install the Sensor. For details, see **Section 2: *Install the Sensor.***
- **Extension Cables:** Test run the Sensor Cable from the chosen mounting location to the control head. 10 ft (3 m) extension cables may be purchased from Humminbird if your planned cable route exceeds 20 ft (6 m). Maximum cable length, including extension cables, should not exceed 50 ft (16 m).
- **Y-Cable:** If the COM port on the control head is already used by another installed accessory, you will need to purchase a Humminbird Y-Cable to add the Sensor to the installation.

2. Install the Sensor

There are three different options to mount the sensor. Proceed to the section that matches the type of mounting location you will be using, as follows:

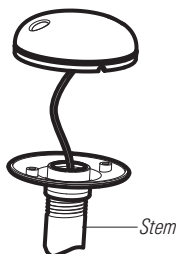

Stem Mount with 1" - 14 Thread

The Sensor will be mounted on a stem or antenna pole. **Proceed to Section A.**

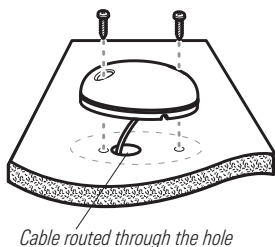

Access Under the Mounting Deck

The Sensor will be deck mounted and the cable can be routed down through the mounting surface. **Proceed to Section B.**

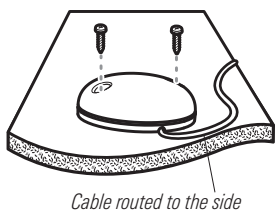

NO Access Under the Mounting Deck

The Sensor will be deck mounted and the cable must be routed to the side because there is not space for a cable through or underneath the mounting location. **Proceed to Section C.**

A. Stem Mount with 1"-14 Thread

Use the following instructions to stem mount the Sensor.

WARNING! Do NOT mount the Sensor to a stem mount or antenna pole that contains ferrous metals.

NOTE: It is important to review the mounting considerations and test run the cable route as indicated in Section 1 before proceeding with the installation.

1. If you have a pre-existing stem mount, skip to step 2.

If you need to mount the antenna pole (stem), mark the chosen mounting location and drill a 3/4" (19 mm) hole for the cable and cable connector.

If you have purchased hardware to stem mount your Sensor, follow the instructions included with that hardware to attach the stem to the boat.

2. Screw the Sensor base onto the stem first, making sure that the stem pipe does not protrude from the Sensor base. (This adds protection to the cable when it is pulled through the pipe stem.) Deburr the pipe edges to reduce cable abrasion.
3. Use electrical tape to secure the NMEA pigtail to the cable.

NOTE: Unless it is needed, leave the NMEA pigtail secured to the cable. If you are connecting the pigtail to a NMEA 0183 device, see **Section 3: Connect to the Control Head** for connection information.

Stem Mount, Attaching the Sensor Base to the Stem

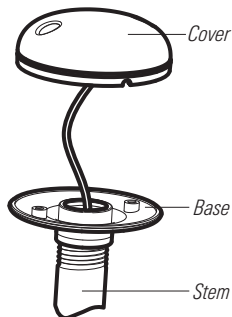

Taping the NMEA Pigtail to the Cable

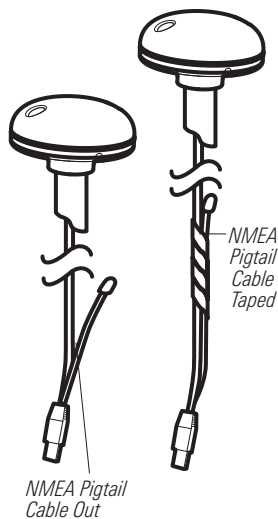

4. Route the Sensor cable through the stem and through the planned cable route. To use extension cables, see the details in **Section 1: Choose the Mounting Location**.
5. Position the Sensor so the arrow on the cover is pointed straight toward the front of the boat in the direction of travel. The arrow should be parallel with the keel.

NOTE: Failure to align the Sensor correctly will result in incorrect compass readings.

6. Attach the Sensor to its base using the included #6 - 7/8" (22 mm) screws. **Hand tighten only.**

Positioning the Arrow on the Sensor

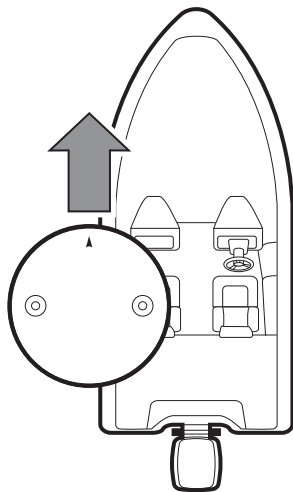

Attaching the Sensor to the Base

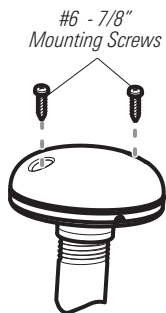

B. Access Under the Mounting Location

Use the following instructions to deck mount the Sensor and route the cable down through the mounting surface.

NOTE: It is important to review the mounting considerations and test run the cable route as indicated in Section 1 before proceeding with the installation.

1. Mark the mounting location and drill a 3/4" (19 mm) hole for the cable and cable connector.
2. Secure the NMEA pigtail to the cable with electrical tape.

NOTE: Unless it is needed, leave the NMEA pigtail secured to the cable. If you are connecting the pigtail to a NMEA 0183 device, see **Section 3: Connect to the Control Head** for connection information.

3. Route the Sensor cable through the planned cable route. To use extension cables, see the details in **Section 1: Choose the Mounting Location**.
4. Cover the cable hole with the Sensor.

Position the Sensor so the arrow on the cover is pointed straight toward the front of the boat in the direction of travel. The arrow should be parallel with the keel.

NOTE: Failure to align the Sensor correctly will result in incorrect compass readings.

Taping the NMEA Pigtail to the Cable

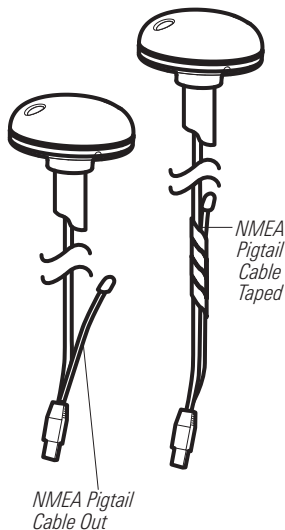

5. Make sure the Sensor is flush against the surface, and mark the two mounting holes with a pencil or awl.
6. Move the Sensor to the side and drill two pilot holes, using a 5/32" (4 mm) bit.

NOTE: Apply marine-grade silicone caulk or sealant to both screw and drilled holes as needed to protect your boat from water damage.

7. Align the Sensor screw holes over the pilot screw holes and attach with the #8 - 1/4" (32 mm) Phillips head screws. **Hand tighten only.**

NOTE: If the mounting surface is thin or made of a light-weight material, you may need to add reinforcing material below the mounting surface in order to support the Sensor.

Positioning the Arrow on the Sensor

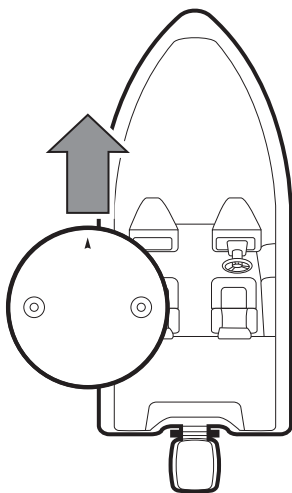

Attaching the Sensor to the Mounting Surface

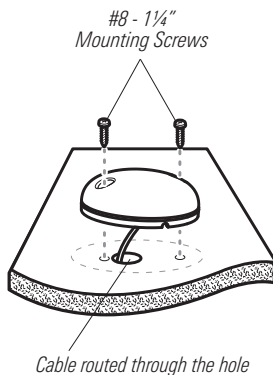

C. No Access Under the Mounting Location

Use the following instructions to deck mount the Sensor and route the cable to the side if there is not space for a cable underneath the mounting location.

NOTE: It is important to review the mounting considerations and test run the cable route as indicated in Section 1 before proceeding with the installation.

1. Secure the NMEA pigtail with electrical tape.

NOTE: Unless it is needed, leave the NMEA pigtail secured to the cable. If you are connecting the pigtail to a NMEA 0183 device, see **Section 3: Connect to the Control Head** for connection information.

2. Route the cable from the Sensor to the Control head.

- The Sensor has two wire routing notches. Use the cable notch closest to the intended cable route.
- If holes are required to route the cable, they must be $3/4"$ (19 mm) to allow for the cable connector.
- To use extension cables, see the details in **Section 1: Choose the Mounting Location**.

Taping the NMEA Pigtail to the Cable

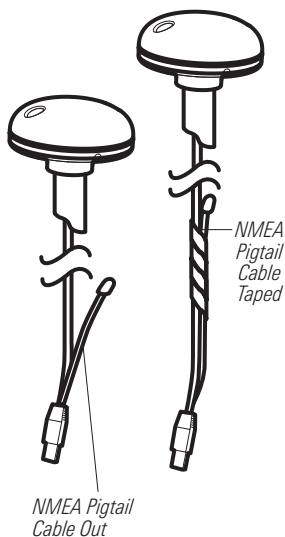

3. With the cable routed, position the Sensor so the arrow on the cover is pointed straight toward the front of the boat in the direction of travel. The arrow should be parallel with the keel.

NOTE: Failure to align the Sensor correctly will result in incorrect compass readings.

4. Make sure the Sensor is flush against the surface, and mark the two mounting holes with a pencil or awl.
5. Move the Sensor to the side and drill the two 5/32" (4 mm) pilot holes.

NOTE: Apply marine-grade silicone caulk or sealant to both screw and drilled holes as needed to protect your boat from water damage.

6. Align the Sensor screw holes over the pilot screw holes and attach with the #8 - 1/4" (32 mm) Phillips head screws. **Hand tighten only.**

Positioning the Arrow on the Sensor

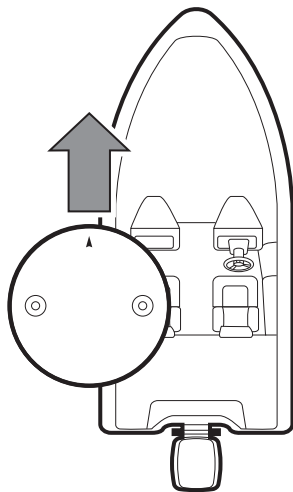

Attaching the Sensor to the Mounting Surface

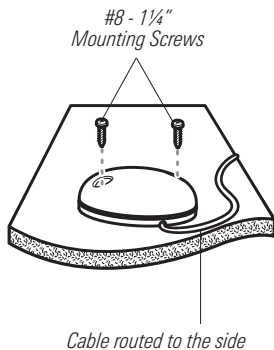

3. Connect to the Control Head

Use the following instructions to connect the Sensor cable to the control head.

1. Insert the Sensor NMEA-COM connector into the control head COM port. The connectors are keyed to prevent reversed installation, so be careful not to force the connector into the port.
 - If there is another accessory plugged into the COM port, install the AS YC ("Y") cable (optional-purchase required).
 - Attach the COM connector of the Y-cable directly to the control head COM port. Connect the Sensor to the NMEA-COM connector of the Y-cable. Reconnect your other Fishfinder accessories to the ACCY-COM connector of the Y-cable. See the illustration *Optional Configuration(s) for the Sensor Installation*.
2. **Optional:** You can connect an optional-purchase device, such as an autopilot, to the Sensor pigtail wires. See the illustration *Optional Configuration(s) for the Sensor Installation*.

The pinouts are as follows:

- **Black Wire (Ground)**
- **White Wire (Control Head NMEA Out):** outputs the navigation calculations and commands from the control head as IN (Integrated Navigation) NMEA sentences. Connect the white wire to the device's NMEA In wire.

OR

- **Green Wire (GPS NMEA Out):** outputs GP (Global Positioning) NMEA sentences directly from the Sensor. Connect the green wire to the device's NMEA In wire if it can only read GP NMEA sentences.

***NOTE:** See your device installation guide to identify the NMEA In wire. The device will connect to the white wire or green wire, depending on its NMEA communication requirements (IN or GP).*

***NOTE:** See **Section 6: Turn on NMEA Output and Confirm the Baud Rate** for more information.*

WARNING! It is important to finish all installation connections before powering on the control head.

Optional Configuration(s) for the Sensor Installation

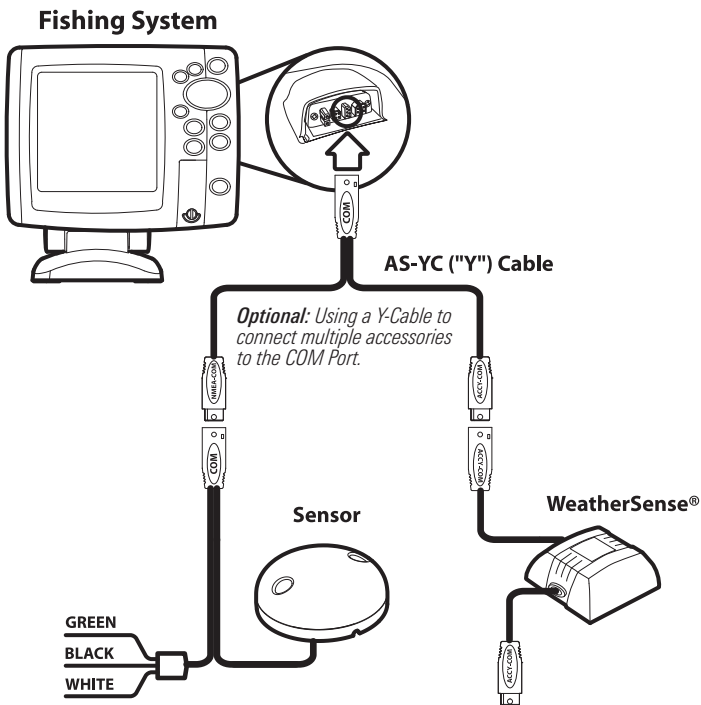

Optional: Using the Sensor wires to connect to a separately-purchased device. For connection details, see step 2.

Install the Trolling Motor Bracket

Use the following instructions to install the Trolling Motor 360 Imaging. It is important to read the instructions completely and understand the mounting guidelines before you start the installation.

WARNING! *Disconnect the motor from all sources of electrical power before you start installation.*

WARNING! *Confirm that the trolling motor is properly secured to the boat and will not shift during installation.*

1 | Prepare for Installation

1. Disconnect the motor from all sources of electrical power.
2. Test run the Ethernet cable from the chosen mounting location on the trolling motor to the control head (or optional Ethernet Switch). Test run the power cable from the chosen mounting location on the trolling motor to the main switch or fuse panel.

It is important to consider the following:

- The 360 Imaging transducer pod is powered separately from the control head. It must be connected to a switch where it can be powered on when the boat is underway and powered off when it is docked.
 - The cables should be routed through an established routing system on the boat, in an area with minimal interference, without sharp edges, obstacles, or obstructions that may damage the cables.
 - The cables will move with the trolling motor when it is deployed and retracted, so it is important to allow enough length for movement.
3. With the trolling motor deployed, the transducer pod should not have anything obstructing the 'view' of the rotating beams (besides the trolling motor and shaft). If possible, move anything to the sides and below the pod that might obstruct the sight line of the rotating beams.

2 | Install the Trolling Motor Bracket

WARNING! Disconnect the motor from all sources of electrical power before you start installation.

WARNING! Confirm that the trolling motor is properly secured to the boat and will not shift during the installation.

The trolling motor should be in the fully retracted (flat) position on the boat deck for this installation.

1. Align the bracket below the BowGuard and slightly above the collar. Close the bracket, but do NOT lock it.
2. Route the cables and pod shaft up through the smaller hole on the trolling motor bracket.

Aligning the Bracket

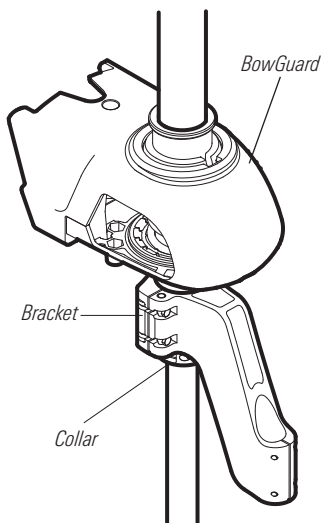

Routing the Cables and Pod Shaft

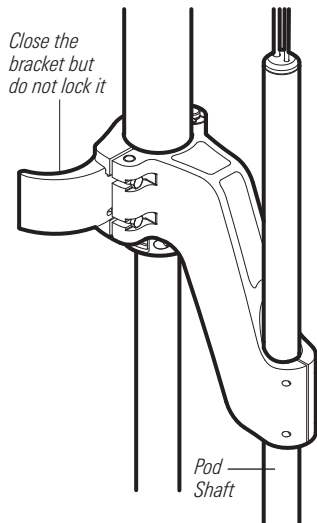

- Adjust the pod shaft up or down, so the pod is at least 1" (25.4 mm) off the tip of the propeller.

WARNING! DO NOT INSTALL THE POD TOO CLOSE TO THE PROP. If the pod is installed too close to the propeller, it will be damaged.

Adjusting the Pod Height (at least 1" from the tip of the propeller)

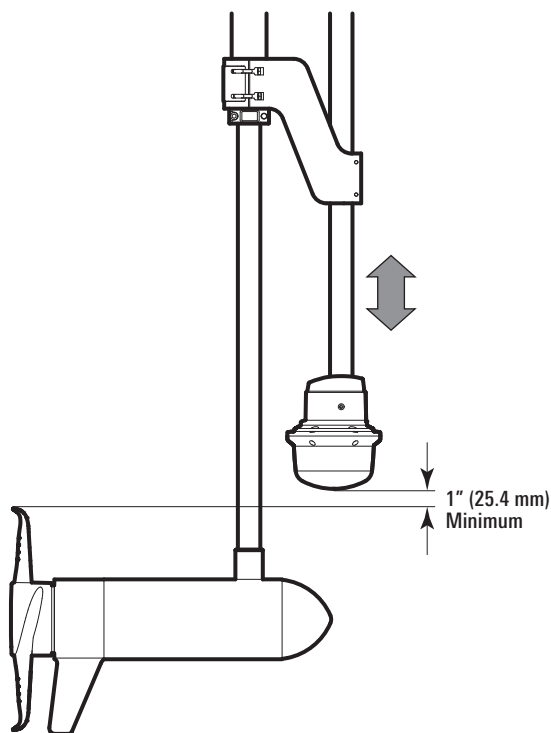

- Pivot the bracket until the pod is at least 2" (50.8 mm) from the lift assist base and at least 1/2" (13 mm) from the trolling motor shaft. See the illustration **Measuring the Safety Distance of the Pod** and **Positioning the Bracket**.

WARNING! The pod must not hit the trolling motor shaft, lift assist base, or any objects. These measurements are also critical during transport when the pod is stowed with the trolling motor.

Measuring the Safety Distance of the Pod

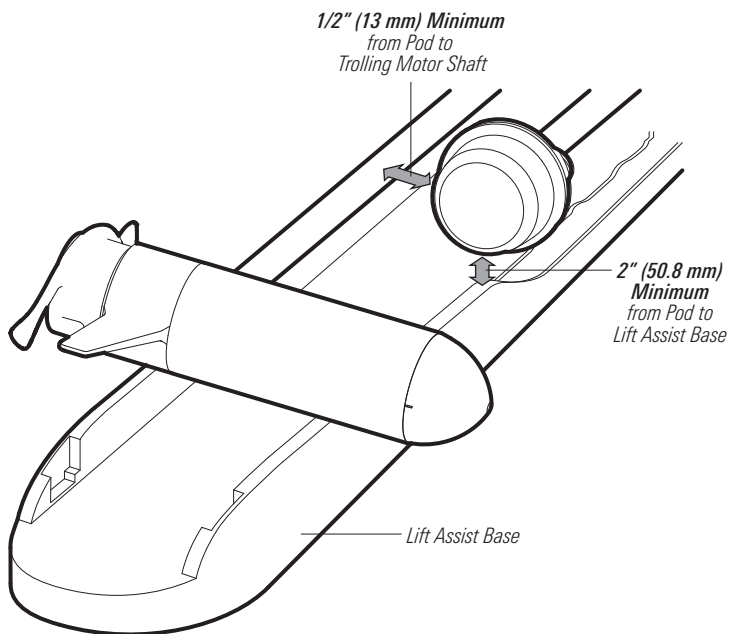

5. Close the bracket lock.

NOTE: For a secure installation, it should take significant force to lock down the bracket. The bracket lock can be tightened by adjusting the tightness of the screws (see the illustration **Positioning the Bracket**). If you adjust the screws, make sure you adjust each screw equally.

6. Use an Allen wrench to install the (2) 10-32 x 5/8" hex socket bolts on the bracket where the pod shaft is installed (see the illustration **Securing the Pod**).

Tighten the bolts so the pod shaft is fully secure and won't drop when it is deployed in the next step. Hand tighten only.

7. Deploy the Trolling Motor.

Positioning the Bracket

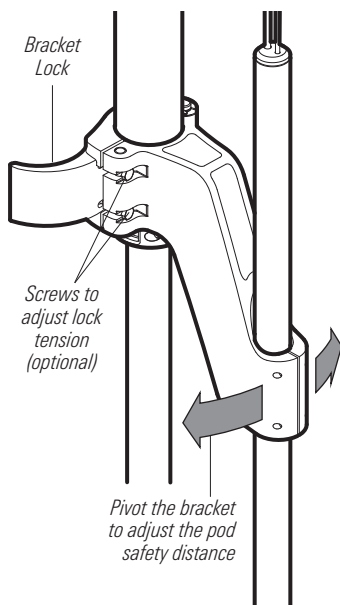

Securing the Pod

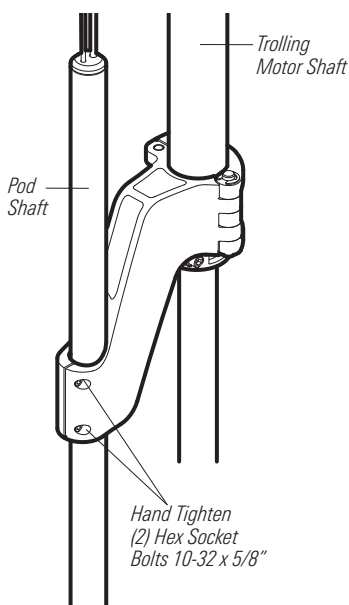

- Turn the pod shaft until the rounded end of the transducer points in the direction of travel. The centerline of the transducer should be parallel with the centerline of the boat. See the illustration ***Aligning the Transducer***.

NOTE: You might need to loosen the hex socket bolts to adjust the transducer alignment.

- When the transducer position is finalized, hand-tighten the hex socket bolts completely so the pod shaft is fully secure and won't drop or rotate during operation. **Hand tighten only.**

Aligning the Transducer

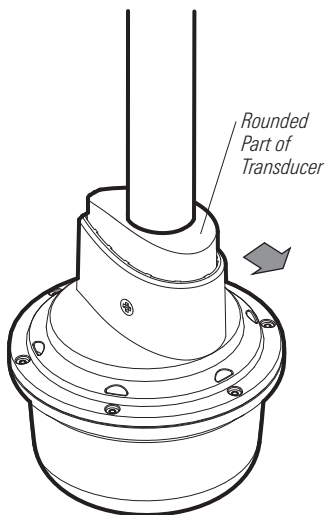

Confirming the Pod is Secure

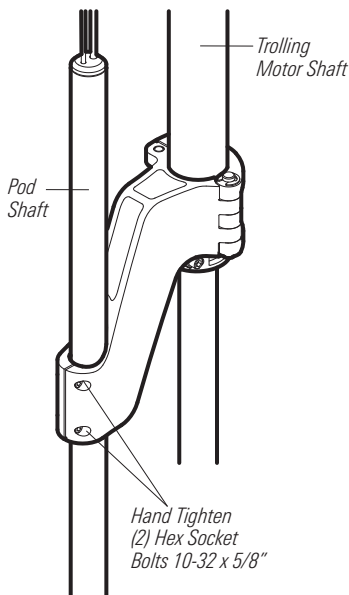

10. Above the BowGuard, unscrew the Depth Collar Knob to remove the clamp.
11. Install the large insert into the slotted side of the clamp. Use a Phillips screwdriver to install the #8-1/2" screw through the clamp and large insert (see the illustration *Installing the Inserts*).
12. Install the small insert into the solid side of the clamp. Hold it in place, and re-install the clamp and Depth Collar Knob. Make sure the clamp notch is facing down and fits onto the collar node (see the illustrations *Installing the Inserts* and *Re-installing the Depth Collar Knob*).
13. Fully hand-tighten the Depth Collar Knob.

NOTE: The Depth Collar knob must be tightened fully to prevent the bracket from rotating and potentially damaging the pod. Hand tighten only.

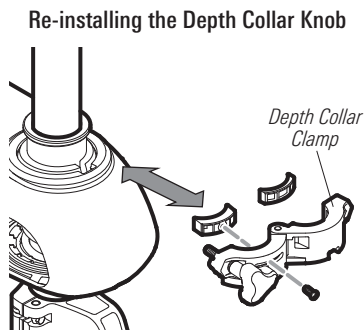
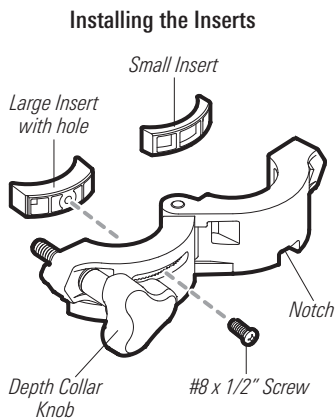

3 | Route the Cables and Connect Power

WARNING! The power source must be turned off before you proceed with this installation.

1. Connect the power cable to the power cable connector on the pod shaft, and connect the Ethernet cable to the Ethernet cable connector on the pod shaft.

The connectors are keyed to prevent reversed installation, so be careful not to force the connectors into the wrong connectors. Hand tighten the screw nuts on each connector (see the illustration *Hand-tightening the Screw Nut*).

2. Route the cables to the side of the trolling motor, over the bow, to the chosen connection locations in **Section 1: Prepare for Installation**. Leave sufficient slack in the cables to allow for full movement of the trolling motor during normal operation.

NOTE: The cables should be routed through an established routing system on the boat, in an area with minimal interference. Inspect the selected route carefully to ensure that there are no sharp edges, obstacles, or obstructions that may damage the cables.

CAUTION! Do NOT mount the cables where the connectors could be submerged in water or flooded. If cables are installed in a splash-prone area, it may be helpful to apply dielectric grease to the inside of the connectors to prevent corrosion. Dielectric grease can be purchased separately from a general hardware or automotive store.

3. **Ethernet:** Insert the other end of the Ethernet Cable into the Ethernet port on the control head. Hand-tighten the screw nut.

NOTE: If you have a 700 Series unit with Ethernet, connect the Ethernet Cable to the Ethernet Adapter Cable (AS EC QDE). Insert the connector into the Ethernet port on the cable collector. See your control head installation guide for details about installing the Quick Disconnect Mount.

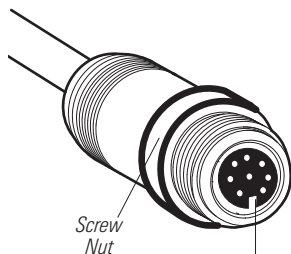

The connectors are keyed to prevent reversed installation.

700 Series Cable Collector with Ethernet

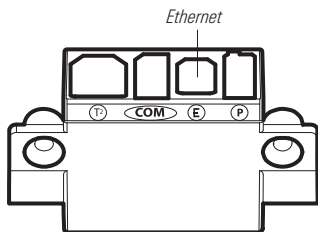

800/900 Series (rear view)

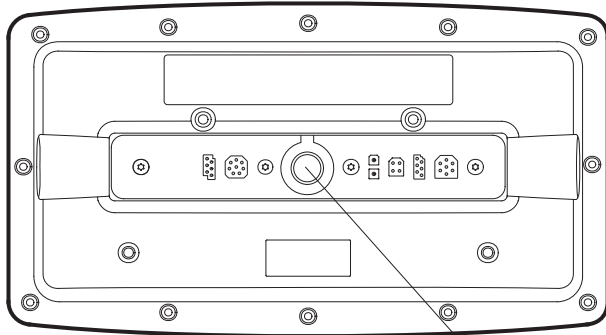

1100 Series (rear view)

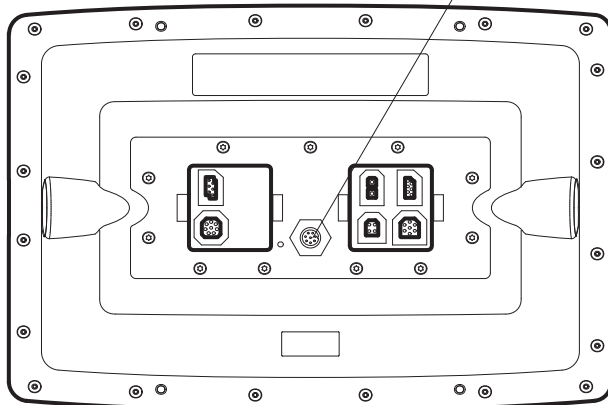

Ethernet Port

WARNING! The 360 Imaging transducer should be connected to a main switch, fuse panel, or battery switch. Humminbird does not recommend connecting to a battery without a fuse and a switch.

NOTE: Humminbird is not responsible for over-voltage or over-current failures. The 360 Imaging transducer must have adequate protection through the proper selection and installation of a 1 Amp fuse.

NOTE: A 3' (1 m) power cable is included to supply power to the 360 Imaging transducer. You may shorten or lengthen the cable using 18 gauge multi-stranded copper wire.

CAUTION! Some boats have 24 or 36 Volt electric systems, but the 360 Imaging transducer **MUST** be connected to a 12 VDC power supply.

4. **Power:** Route the power cable to the main switch or fuse panel (usually located near the console). If you must connect to a battery, connect to a battery switch (not included).

- 5a. **Main Switch/Fuse Panel:** If a fuse terminal is available, use crimp-on type electrical connectors (not included) that match the terminal on the fuse panel. Attach the black wire to ground (–), and the red wire to positive (+) 12 VDC power. Install a 1 Amp fuse (not included) for protection of the unit.

OR

- 5b. **Battery Switch:** Install the battery switch (not included) using the instructions provided with it. You will also need to obtain and install an inline fuse holder and a 1 Amp fuse (not included) for the protection of the unit. Attach the black wire to ground (–), and the red wire to positive (+) 12 VDC power.

Connecting to the Fuse Panel

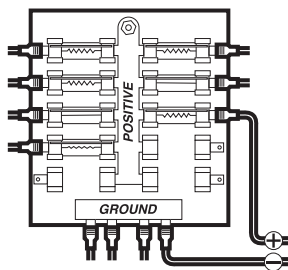

WARNING! If you are unable to obtain a battery switch and are forced to connect the power cable directly to the battery, be aware that this will drain the battery. Humminbird does not recommend connecting to a battery without the appropriate fuse and a switch.

6. Tape the drain wire.
7. Secure the cables with cable ties along the route as needed for a clean assembly.

Set up the Control Head

(700, 800, 900, and 1100 Series)

Use the following instructions to power on the control head and confirm the 360 Imaging transducer and the GPS Receiver/Heading Sensor are detected by the unit.

CAUTION! It is important to finish all installation connections before powering on the control head. It may take up to a minute for the 360 Imaging transducer and other attached equipment to be detected by the control head.

1. Power on and Confirm Connections

1. Turn on the power source from the main switch.
2. On the control head, press the  POWER/LIGHT key. **If you are powering on a control head in a multiple-control head Ethernet network**, power on the control head that is connected to the 360 Imaging transducer first.
3. When the Title screen is displayed, press the MENU key to access the Start-Up Options Menu.
4. Use the 4-WAY Cursor Control key to choose **Normal**, and press the RIGHT Cursor key to select it.
5. Press and hold the VIEW key. Select System > Accessory Test. Confirm that **360 Imaging** and **GPS + Heading Sensor** are listed as Connected. It will take a minute for the equipment to be detected.
6. Press and hold the VIEW key. Select System > GPS Diagnostic View. Confirm that External GPS is displayed and the Fix Type indicates Enhanced or 3D.

NOTE: *If the GPS Diagnostic View or Accessory Test is not displayed in the View Rotation, press the MENU key twice to open the Main Menu. Select the Views tab > GPS Diagnostic View or Accessory Test. Change the setting for each view to Visible.*

Accessory Test

SYSTEM STATUS	
ACCESSORY TEST	
360 Imaging v.1.090	CONNECTED
Aux. Temperature	UNCONNECTED
CannonLink	UNCONNECTED
GPS + Heading Sensor	CONNECTED
i-Pilot	UNCONNECTED
InterLink	UNCONNECTED
NMEA2K Gateway	UNCONNECTED
Radar	UNCONNECTED
Speed	UNCONNECTED
Temperature	CONNECTED
WeatherSense	UNCONNECTED
XM Weather	UNCONNECTED

Depth	ft	Speed	mph	COG	°t	VLT	V
177	N 34°06.252' W 084°12.372'	0.0	291	13.6			

360 Imaging listed as Connected

GPS & Heading Sensor listed as Connected

GPS Diagnostic View

GPS Diagnostic View									
	Fix Type	Enhanced							
	HDOP	1.00							
	Est Pos Error	17ft							
	Altitude	1083ft							
	Speed	5.6mph							
	Course	277°t							
External GPS		SD Card	43/120MB						
7/19/07	NORTH 25°53.999'	SD Card	---						
11:58:45AM	WEST 080°07.648'								
Depth	ft	Temp	°F	Speed	mph	Course	°t	VLT	V
36.4	74.3	5.6	277	11.7					

Fix Type should be 3D or Enhanced

External GPS Detected

2. Set up 360 Imaging on the Control Head

To operate the transducer from the control head, the transducer must be selected from the network. When you select the 360 Imaging transducer from the network, the related views and menus will be added to the system.

Selecting the 360 Imaging Transducer

Press the
RIGHT or
LEFT Cursor
keys to
select a tab.

Network Source Setup				
Status	2D	Adv.	360	T1 GPS
Name	Model			
-----	AS 360	AS 360	455	<input checked="" type="checkbox"/>

Use the 4-WAY
Cursor Control
key to choose the
transducer, and
press the RIGHT
Cursor key or the
CHECK/INFO key
to select it.

Select 360 Imaging on the Network

Confirm that AS 360 is selected in the Network Source Setup dialog box. It might take up to a minute for the equipment to be detected.

NOTE: If AS 360 is already selected (indicated by a check mark), you can skip this step. Proceed to **Test 360 Imaging on the Control Head.**

1. **Main Menu:** Press the MENU key once.
2. Select the Network tab > Network Source Setup. Press the RIGHT Cursor key.
3. Select the 360 tab from the Network Source Setup dialog box.
4. Select **AS 360** from the transducer list. Press the RIGHT Cursor key. A checkmark will display in the box to show it is selected.
5. Press the EXIT key until the dialog box is closed.

WARNING! The pod should NOT be in the water during high speed travel. The pod should only be deployed when the boat is traveling between 0 to 7 mph.

3. Test 360 Imaging on the Control Head

It is important to confirm that the 360 Imaging transducer is providing sonar returns to the display.

***NOTE:** The instructions in this section should be performed at slow speeds (0 to 7 mph), in calm, open water, in a large area that is far from shallow water, boats, or other obstacles.*

Confirm 360 Imaging Sonar Operation

1. Press the VIEW key until the 360 Imaging View is displayed on the screen. The dialog box will display on the screen.

Start Pinging from the 360 View

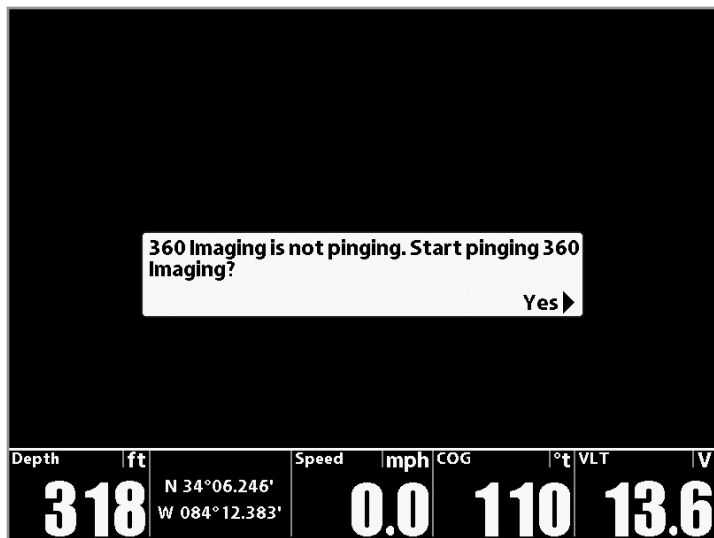

2. **Start Pinging:** Press the RIGHT Cursor key to start using 360 Imaging.

- The sonar returns from the 360 scan will begin to display on the 360 View. Review the display for the following information and see the illustration below:
 - Bottom:** Confirm that the bottom is visible on-screen.
 - Blocked Beams:** If the beams hit a hard surface, it will appear as bright white on the display. If the beams are blocked by any objects, move the objects if possible or adjust the pod height (see the installation section for more information). You can also adjust the 360 Range on the X-Press Menu to see more or less detail on the display. In some cases, the trolling motor will appear on the display as a shadow.
- Stop Pinging:** When you are finished reviewing the operation, press the MENU key once. Select Stop 360 Ping, and press the RIGHT Cursor key.

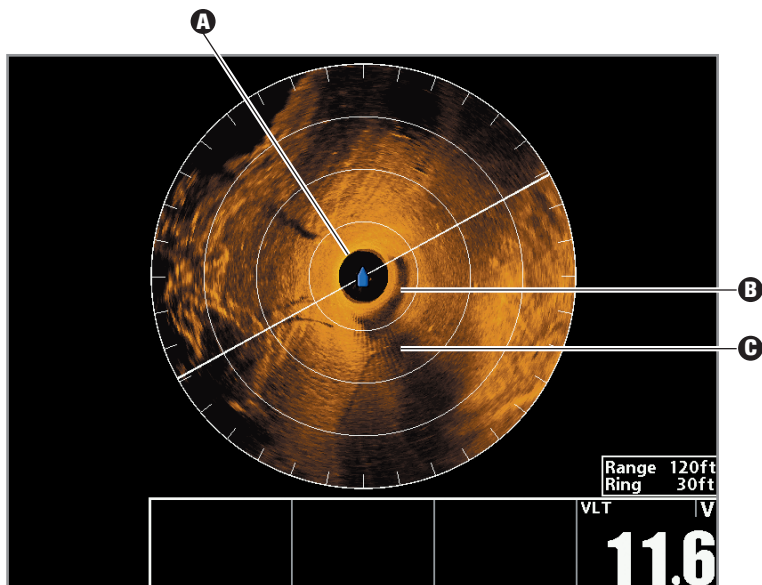

- A** Bottom Return
- B** Trolling Motor Shadow
- C** Propeller Shadow (dark lines)

4. Confirm the Heading Sensor Operation

It is important to confirm that the Heading Sensor is installed correctly by reviewing the heading digital readout.

NOTE: This procedure should be performed at slow speeds, in calm, open water, in a large area that is far from shallow water, boats, or other obstacles.

1. **Main Menu:** Press the MENU key twice.
2. Select the Navigation tab > North Reference > Magnetic.
3. Press the EXIT key.
4. Select the Setup tab > Select Readouts.

NOTE: If the Select Readouts menu option does not appear under the Setup tab, change the User Mode to Advanced. Select Main Menu > Setup tab > User Mode > Advanced.

5. Select a Readout position and use the RIGHT or LEFT Cursor keys to select Heading. Select another Readout position and select Course.
6. Press the EXIT key until the Main Menu is closed.
7. Press and hold the VIEW key. Select Sonar > Sonar View.
8. Navigate the boat in a straight line, in calm, open water at 4.5 mph. Compare the Heading digital readout on the screen with the Course (COG) digital readout. The readouts should be within approximately 5° of each other.

Adjust: To adjust the zero point of the Heading Sensor, select Main Menu > Navigation tab > Heading Offset. Press the RIGHT or LEFT Cursor keys to adjust the setting.

If the procedure failed: If the Heading digital readout is significantly different than the COG, the Heading Sensor might be installed in a location with too much magnetic interference. Check the installation location and possible magnetic disturbances in the area.

Confirming the Heading Digital Readout (1198c SI, Chart View)

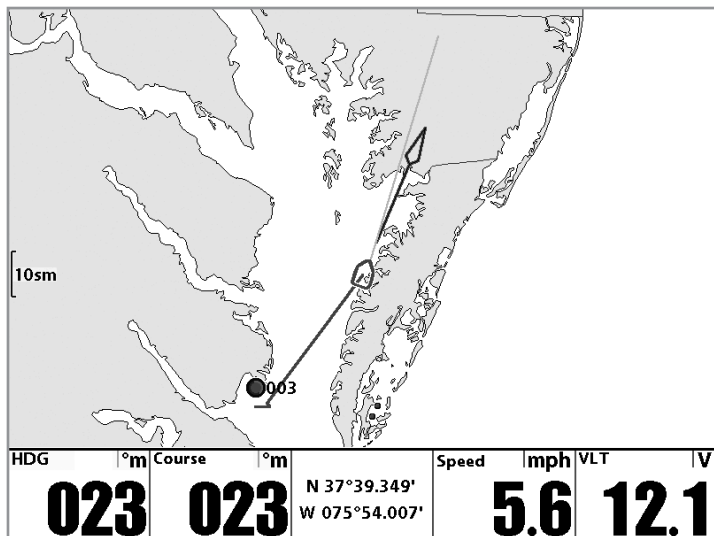

*Heading
(Heading Sensor
Required)*

*Course
(GPS Required)*

5. Add Offset Features to the 360 Imaging Display (optional)

The menu settings in this section are helpful for interpreting the position of objects on the 360 View.

Adjust the 360 Heading Offset

If the positions of objects on the 360 Imaging display are slightly different than what you observe in the environment around you, use 360 Heading Offset to correct the alignment of the 360 Imaging display.

For example, if there is an object in the water that is displayed on the left side of the 360 View, but you can see that it is straight ahead, you can use this setting to rotate the display.

***NOTE:** This menu option should be adjusted while the 360 Imaging transducer is pinging.*

1. **Main Menu:** Press the MENU key twice.
2. Select the Accessories tab > 360 Sonar Settings > 360 Heading Offset.
3. Press the RIGHT or LEFT Cursor keys to change the angle (gray line), and press the CHECK/INFO key to confirm your setting. The zero point on the display is represented by a green line.

Display the 360 Offset Icon

Use 360 Offset to display an icon representing the GPS Receiver/Heading Sensor installation position on the 360 Imaging View. With the 360 Offset Icon displayed, it is easier to interpret the position of objects on the view.

For example, if the GPS Receiver/Heading Sensor is installed 20 feet from the 360 Imaging transducer, set 360 Offset to -20. An icon will be displayed on the view to show the Sensor (puck) position.

1. Measure the distance from the 360 Imaging transducer to the GPS Receiver/Heading Sensor on your boat.
2. **Main Menu:** Press the MENU key twice.

3. Select the Accessories tab > 360 Sonar Settings > 360 Offset.
4. Press the RIGHT or LEFT Cursor keys to set the distance between the 360 Imaging transducer and the GPS Receiver/Heading Sensor. (-30 ft to 0 ft; Default = 0 [Off])

NOTE: The Boat Icon must be set to On for the 360 Offset Icon to be displayed.

360 View with the 360 Offset Icon and Cursor

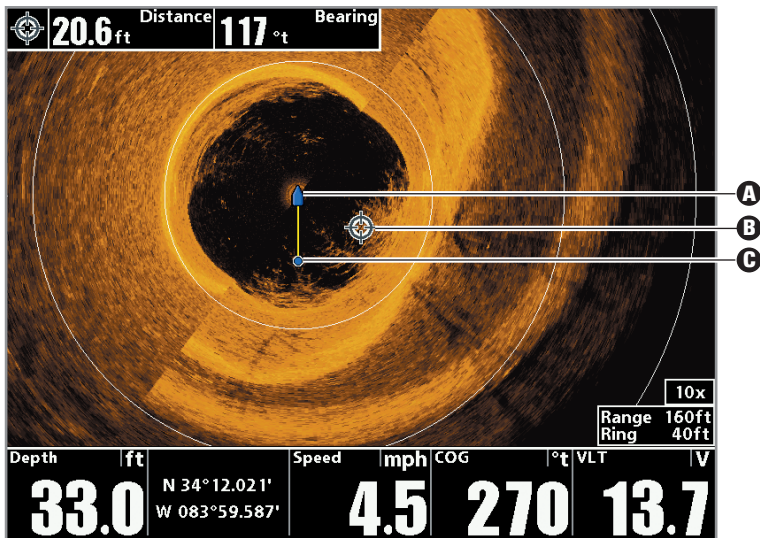

- A** Boat Icon represents the 360 Imaging transducer position
- B** Cursor Position: Located halfway between the 360 Imaging transducer and the GPS/Heading Sensor on the display, on the right side of the boat (allows you to interpret where to cast).
- C** 360 Offset Icon represents the GPS Receiver/Heading Sensor position

6. Turn on NMEA Output and Confirm the Baud Rate

(for devices connected to the Sensor pigtail only)

If you connected a device to the Sensor pigtail wires, turn on NMEA Output to enable communication and output NMEA 0183 sentences from the control head. It is also important to note the following:

- **If the GPS Receiver/Heading Sensor is connected to the control head, and NMEA Output is turned on**, the control head will operate exclusively at a baud rate of 38400. If there is an accessory attached to the Sensor pigtail, it also needs to operate at 38400. See your device's installation guide to set the baud rate to 38400.
- **If NMEA Output is turned off**, then baud rates 4800, 9600, and 38400 are available on the control head, but the device will not receive NMEA data.

Turn On/Off NMEA Output

1. **Main Menu:** Press the MENU key twice.
2. Select the Setup tab > NMEA Output.
3. Press the RIGHT or LEFT Cursor keys to select On or Off. (Default = Off)

***NOTE:** The menu option in your Fishing System will be called NMEA 0183 Output or NMEA Output. If the menu option is not shown under the Setup tab, make sure the User Mode is set to Advanced (Setup tab > User Mode > Advanced).*

7. Set up the Network and Alarms

After you have confirmed all connections, the 360 Imaging transducer is ready to use on the water. Proceed to your 360 Operations Manual to set up the depth source, temperature source, and the 360 Imaging Alarms.

Power Off

WARNING! When the boat is stored or at dock, the 360 Imaging transducer must be turned off to prevent draining the battery.

Power off the Control Head

1. Press and hold the POWER/LIGHT key.

***CAUTION!** Turning off the control head will NOT power off the 360 Imaging transducer.*

2. Turn off power on the main switch, breaker, or battery switch.

***NOTE:** Powering off the 360 Imaging transducer will be determined by the installation and power connection on your boat.*

Travel with the Pod Installed

1. Confirm the Depth Collar Knob is fully tightened (by hand).
2. The pod must not hit the trolling motor shaft, base, or any objects. This is also critical during transport or when the trolling motor is stowed. Check the stability of the trolling motor bracket after initial use and periodically thereafter to ensure that the installation and lock remain stable.

NOTE:** For measurement requirements, see **Install the Trolling Motor Bracket, step 4.

Maintenance

Your Humminbird fishfinder is designed to provide years of trouble free operation with very little maintenance. Use the following procedures to ensure your Humminbird continues to deliver top performance.

Control Head Maintenance

It is important to consider the following precautions when using your Humminbird control head:

- **Chemicals**, such as those found in bug spray and sunscreen, may cause permanent damage to the control head screen. Such damage is not covered by the warranty.
- **NEVER leave the control head in a closed car or trunk.** The high temperatures generated in hot weather can damage the electronics.

Use the following information to keep the control head and screen clean.

- **Screen:** To clean the control head screen, use a mild soap (such as a non-abrasive liquid hand soap) and warm water. Wipe the screen dry with a soft cloth. Be careful to avoid scratching the screen. If water spots remain, use a solution of water and vinegar.

***WARNING!** Do not use a chemical glass cleaner on the screen. Chemicals in the solution may cause cracking in the lens of the unit.*

***NOTE:** Do not wipe the screen while dirt or grease is on the screen.*

- **Control Head:** If the control head comes into contact with salt spray, wipe the affected surfaces with a cloth dampened with fresh water.

Transducer Maintenance

Use the following information to maintain the transducer operation.

- If your boat remains in the water for long periods of time, algae and other marine growth can reduce the effectiveness of the transducer. Periodically clean the face of the transducer with a cloth dampened with fresh water.
- If your boat remains out of the water for a long period of time, it may take some time to wet the transducer when it is returned to the water. Small air bubbles can climb to the surface of the transducer and interfere with proper operation. These bubbles dissipate with time, or you can wipe the face of the transducer with your fingers after the transducer is in the water.

Trolling Motor 360 Imaging Maintenance

Use the following information to maintain the installation of the 360 Imaging Transducer.

- Check the stability of the trolling motor bracket after initial use and periodically thereafter to ensure that the installation and lock remain stable.
- If your boat will be in long-term storage, remove the 360 Imaging pod shaft from the bracket and store it in -40°F to 158°F (-40°C to 70°C), dry conditions.

Troubleshooting

Before contacting the Humminbird Customer Resource Center, please read the following section. Taking the time to review these troubleshooting guidelines may allow you to solve a performance problem yourself, and therefore avoid sending your unit back for repair.

Fishing System Doesn't Power Up

If your Fishing System doesn't power up, use the installation guide that is included with your Fishing System to confirm specific details, making sure that:

- the power cable is properly connected to the Fishing System control head,
- the power cable is wired correctly, with red to positive battery terminal and black to negative terminal or ground,
- the fuse is operational, and
- the battery voltage of the power connector is at least 10 Volts.

Correct any known problems, including removing corrosion from the battery terminals or wiring, or actually replacing the battery if necessary.

Fishing System Defaults to Simulator with a Transducer Attached

In addition to the 360 Imaging accessory transducer, you will have a standard Humminbird transducer connected to the control head. A connected and functioning transducer with built-in temperature will cause the newly-started Fishing System to go into Normal operating mode automatically. If, when you power up the Fishing System, it goes into Simulator mode automatically, even though a transducer is already connected, this means that the control head is not detecting the transducer. Perform the following troubleshooting tasks:

- Check the connections of all transducers that are connected to the control head or Ethernet network. See the transducer installation guide that was included with your Fishing System for connection information.
- Review this 360 Imaging installation guide to confirm that the transducer cable is connected correctly to the Fishing System. Reconnect if necessary, and power on the Fishing System again to see if this fixes the problem.
- Because the 360 Imaging transducer is on the network, it might take up to a minute to be detected on the network. Use the 4-WAY Cursor Control key to select Normal from the Start-Up Options Menu. In this guide, see ***Set up the Control Head, Section 1. Power on and Confirm Connections.***
- Replace the non-functioning transducer with a known good transducer if available and power up the control head again.
- Check the transducer cable. Replace the transducer if the cable is damaged or corroded.

Finding the Cause of Noise

Electrical noise usually affects the display with streaks or repetitive patterns on the view. One or more of the following sources can cause noise or interference:

Possible Source of Noise

Isolation

Other electronic devices

Turn off any nearby electronic devices to see if the problem goes away, then turn them on one at a time to see if the noise re-appears.

The boat's engine

To determine whether the boat's engine is the source of the noise, increase the RPMs while the boat is in neutral and stationary to see if the noise increases proportionately; if noise appears when you rev the engine, the problem could be the spark plugs, alternator, or tachometer wiring. Replace the spark plugs with resistor plugs, install an alternator filter, or route the control head power and transducer cables away from the engine wiring.

Cavitation from the boat's propeller

Turbulence created by the propeller can cause noise; make sure the transducer is mounted at least 6" (15.24 cm) from the propeller, and that the water flows smoothly over the face of the transducer at all times.

Specifications

Operating Frequency	455 kHz
Area of Coverage	455 kHz: (2) 90° @ -10 dB
Target Separation	2 1/2 inches (63.5 mm)
Power Output	500 Watts (RMS), 4000 Watts (Peak to Peak)
Power Requirement	10 to 20 VDC
Current Draw	.5 A maximum
Operating Temperature	32°F to 158°F (0°C to 70°C)
Storage Temperature	-40°F to 158°F (-40°C to 70°C)

NOTE: Humminbird verifies maximum stated depth in saltwater conditions, but actual depth performance may vary due to transducer installation, water type, thermal layers, bottom composition and slope.

NOTE: Product specifications and features are subject to change without notice.

ENVIRONMENTAL COMPLIANCE STATEMENT: *It is the intention of Johnson Outdoors Marine Electronics, Inc. to be a responsible corporate citizen, operating in compliance with known and applicable environmental regulations, and a good neighbor in the communities where we make or sell our products.*

WEEE DIRECTIVE: *EU Directive 2002/96/EC "Waste of Electrical and Electronic Equipment Directive (WEEE)" impacts most distributors, sellers, and manufacturers of consumer electronics in the European Union. The WEEE Directive requires the producer of consumer electronics to take responsibility for the management of waste from their products to achieve environmentally responsible disposal during the product life cycle.*

WEEE compliance may not be required in your location for electrical & electronic equipment (EEE), nor may it be required for EEE designed and intended as fixed or temporary installation in transportation vehicles such as automobiles, aircraft, and boats. In some European Union member states, these vehicles are considered outside of the scope of the Directive, and EEE for those applications can be considered excluded from the WEEE Directive requirement.



This symbol (WEEE wheeled bin) on product indicates the product must not be disposed of with other household refuse. It must be disposed of and collected for recycling and recovery of waste EEE. Johnson Outdoors Marine Electronics, Inc. will mark all EEE products in accordance with the WEEE Directive. It is our goal to comply in the collection, treatment, recovery, and environmentally sound disposal of those products; however, these requirements do vary within European Union member states. For more information about where you should dispose of your waste equipment for recycling and recovery and/or your European Union member state requirements, please contact your dealer or distributor from which your product was purchased.

Contact Humminbird®

Contact the Humminbird® Customer Resource Center
in any of the following ways:

By Telephone:

(Monday - Friday 8:00 a.m. to 4:30 p.m. Central Standard Time):

1-800-633-1468

By e-mail:

(typically we respond to your e-mail within three business days):

service@humminbird.com

For direct shipping, our address is:

Humminbird

Service Department

678 Humminbird Lane

Eufaula, AL 36027 USA

